

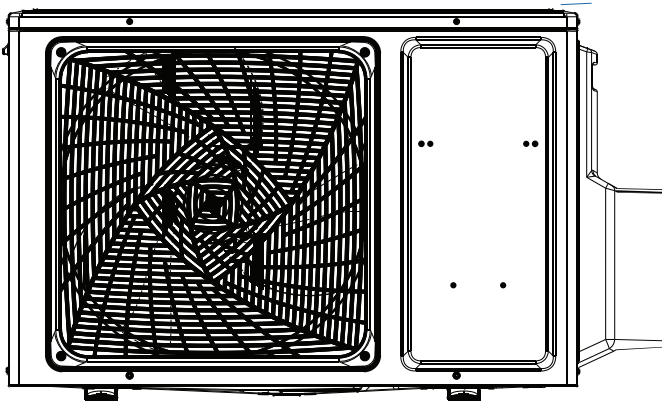

Service Manual

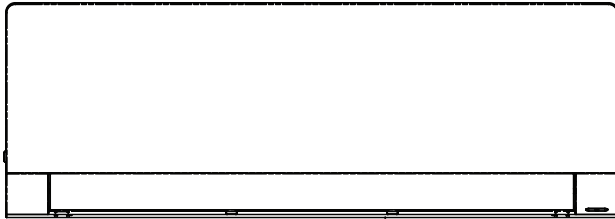

INDOOR

- AW09TE1VHA
- AW12TE1VHA
- AW09TE2VHA
- AW12TE2VHA
- AW18TE2VHA
- AW24TE2VHA
- ASYW09CRAWA
- ASYW12CRAWA
- ASYW09CRDWA
- ASYW12CRDWA
- ASYW18CRDWA
- ASYW24CRDWA

OUTDOOR

- 1U09TE1VHA
- 1U12TE1VHA
- 1U09TE2VHA
- 1U12TE2VHA
- 1U18TE2VHA
- 1U24TE2VHA
- ASH109CRAWA
- ASH112CRAWA
- ASH118CRDWA
- ASH124CRDWA

Design may vary by model number.

- Please read this manual before installing this product.
- **Keep this service manual for future reference.**

Table of Contents

Safety Precautions/Introduction	3
INDOOR MODELS: AW09TE1VHA, AW12TE1VHA, AW18TE2VHA, AW24TE2VHA, ASYW09CRAWA, ASYW12CRAWA, ASYW18CRDWA, ASYW24CRDWA	
OUTDOOR MODELS: 1U09TE1VHA, 1U12TE1VHA, 1U18TE2VHA, 1U24TE2VHA, ASH109CRAWA, ASH112CRAWA, ASH118CRDWA, ASH124CRDWA	
Outdoor Unit Controls and Components	7
Indoor Unit Controls and Components	13
Sequence Of Operation	19
System Specifications	25
Error codes and Troubleshooting	27
Reference Information	56
INDOOR MODELS: AW09TE2VHA, AW12TE2VHA, ASYW09CRDWA, ASYW12CRDWA	
OUTDOOR MODELS: 1U09TE2VHA, 1U12TE2VHA, ASH109CRDWA, ASH112CRDWA	
Outdoor Unit Controls and Components	83
Indoor Unit Controls and Components	89
Sequence Of Operation	95
System Specifications	103
Error codes and Troubleshooting	104
Reference Information	133

[This page intentionally left blank.]

Table of Contents

<i>Safety Precautions</i>	4
<i>Warnings and Cautions</i>	4
<i>Introduction to System</i>	5
<i>Specifications for proper operation should be followed</i>	5
<i>System Fundamentals</i>	5

Safety Precautions

- Read these Safety Precautions carefully to ensure correct installation.
- This manual classifies the precautions into WARNING and CAUTION.
- Be sure to follow all the precautions below: they are all important for ensuring safe
- ⚠ **WARNING:** Failure to follow any WARNING could result in serious injury or death.
- ⚠ **CAUTION:** Failure to follow any CAUTION may in some cases result in grave consequences.
- The following safety symbols are used throughout this manual.



Be sure to observe this instruction



Be sure to establish an earth connection



Never attempt

- After completing installation, test the unit to check for installation errors. Give the user adequate instructions concerning the use and cleaning of the unit according to the Operation Manual.

⚠ WARNING

Improper installation may cause water leakage, electrical shock, or fire.

- Install the heat pump according to the instructions given in this manual. Incomplete installation may cause water leakage, electrical shock, or fire.

- Be sure to use the supplied or specified installation parts. Use of other parts may cause the unit to come loose, water leakage, electrical shock, or fire

- Install the heat pump on a solid base that can support the unit's weight. An inadequate base or incomplete installation may cause injury in the event the unit falls off the base.

- Electrical work should be carried out in accordance with the installation manual and national, state, or local code. Insufficient capacity or incomplete electrical work may cause electrical shock or fire.

- Be sure to use a dedicated power circuit. Never use a power supply shared by another appliance.

- For wiring, use a cable long enough to cover the entire distance with no splicing.

- Use the specified types of wires for electrical connections between the indoor and outdoor units. Firmly clamp the interconnecting wires to avoid stress or sharp edges. Incomplete connections or clamping may cause terminal overheating or fire.

- After connecting the wiring, be sure to route the cables so that they do not put undue force on the electrical covers or panels. Install covers over the wires. Incomplete cover installation may cause terminal overheating, electrical shock, or fire.

- If any refrigerant has leaked out during the installation work, ventilate the room. (The refrigerant produces a toxic gas if exposed to flames.)

- After all installation is complete, check to make sure that no refrigerant is leaking out. (The refrigerant produces a toxic gas if exposed to flames.)

- When installing or relocating the system, be sure to keep the refrigerant circuit free from substances other than the specified refrigerant (R410A), such as air or moisture. (Any presence of air or other foreign substance in the refrigerant circuit causes an abnormal pressure rise or rupture, resulting in injury.)

- Be sure to establish a ground. Do not ground the unit to a utility pipe, arrester, or telephone earth. Inadequate grounding may cause electrical shock, or fire. A high surge current from lightning or other sources may cause damage.



⚠ CAUTION

- Do not install this system in a place where there is danger of exposure to inflammable gas leakage. If the gas leaks and builds up around the unit, it may catch fire.



- Install drain piping according to the instructions of this manual. Inadequate piping may cause flooding.

- Tighten the flare nuts with a torque wrench. If the flare nut is tightened too hard, the flare nut may crack after a long time and cause refrigerant leakage.

- Maintain proper clearances around unit per this manual.

Introduction to System

Single Zone Ductless Split System Heat Pumps feature a wall mounted indoor fan/evaporator unit that receives refrigerant from an inverter driven variable speed outdoor condensing unit. The system operation is controlled with a remote control.

The outdoor unit features a variable speed rotary compressor, EEV metering device and DC fan motor. These systems use R410A refrigerant and PVE oil. The outdoor units are 115 volt for old models 9K /12K, and 208/230 volt rated systems for new models 9K/12K and 208/230 volt for 18K/24K. They come factory charged for up to 25 ft. of interconnecting piping.

The indoor units are wall mounted. They feature a DC blower motor and a DC louver motor. The unit has a room temperature sensor and an evaporator tube temperature sensor. The wall unit is powered by voltage from the outdoor unit.

Specifications for Proper Operation

- The systems are designed to operate in temperature. The indoor unit can be set from 60°F-86°F (16°C-30°C) during both cooling and heating
- PVE oil is non-reactive to water and will not go into hydrolysis. There is no need to add a refrigeration drier when servicing or installing this system.
- The indoor wall mounted unit receives operating voltage and communication data signals on #14 AWG wire that connects between the indoor and outdoor units. There should not be any splices in the field wiring that goes between terminals 1, 2, 3 and 4. A splice in these wires may cause the system to lose communication between the indoor and outdoor units. The system will then display an error code E7.
- The field-supplied refrigerant tubing connects using flare type fittings at both the indoor and outdoor units. Tubing must be sized per the specifications. Both lines must be insulated. The only method of checking charge or adjusting charge is by weight method explained in this manual (no exceptions).
- The condensate system is a gravity type. A field installed condensate pump may be added to the system. Always follow the manufacturer's installation instructions when installing a condensate pump.
- Proper clearances at both indoor and outdoor units must be maintained. Improper clearances cause incorrect refrigerant pressures and coil freezing.

System Fundamentals

The indoor unit will sense room temperature at the point where the wall unit is installed. The indoor fan will run continuously when placed in heating or cooling mode and will not cycle on and off with the outdoor unit. If it did, room temperature could not be sensed or maintained.

The inverter compressor system in the outdoor unit will vary the refrigerant flow and indoor air volume levels to match the comfort requirement inside the conditioned space. If an abnormal condition is detected by the system's sensors, the system has the ability to take reactive measures.

The amount of refrigerant flow and associated capacity generated by the system will be determined by how fast the system's variable speed rotary compressor is pumping. The compressor operating speed is determined by the difference between the conditioned space temperature and the set point

If a large amount of capacity is needed, the compressor will operate at a high speed. As the need for capacity reduces and the temperature of the room nears set point, the compressor will slow down. When set point has been reached, the compressor will shut off while the fan continues to operate. When a difference in temperature is sensed between the set point and room, the compressor will restart at a new calculated speed.

If a system sensor determines there is a need to adjust the frequency signal to prevent a system malfunction, the compressor frequency may be over ridden and a new frequency established. It should be noted that the frequency signal level that is sent to the compressor cannot be determined by a servicing technician.

In this manual, system components, operation, sensor functions, and diagnostic procedures will be explained in greater detail.

[This page intentionally left blank.]

Table of Contents

Unit Introduction 8
Component Identification..... 8
Main Control Board 9
Terminal Block..... 10
Reactor 10
Compressor 10
Fan Motor 10
Discharge Temperature Sensor 11
Defrost Temperature Sensor 11
Ambient Temperature Sensor 11
Suction Line Temperature Sensor..... 11
4-Way Valve 12
Electronic Expansion Valve..... 12
Accumulator 12
Filters..... 12

Outdoor Unit Introduction

The outdoor unit has two circuit boards, an Inverter Power Module (IPM) that drives the compressor and a main control board (PCB) that manages system functions and inverter calculations. Temperature Sensors monitor key temperatures throughout the system to manage operational decisions.

Outdoor Component Identification

- 1 4-Way Valve
- 2 Accumulator
- 3 Compressor
- 4 Defrost Temperature Sensor
- 5 Discharge Temperature Sensor
- 6 Electronic Expansion Valve
- 7 Refrigerant Strainers
- 8 Ambient Temperature Sensor
- 9 Fan Motor
- 10 Power Factor Reactor
- 11 Suction Line Temperature Sensor
- 12 Terminal Block
- 13 PCB
- 14 IPM
- 15 Fan Blade

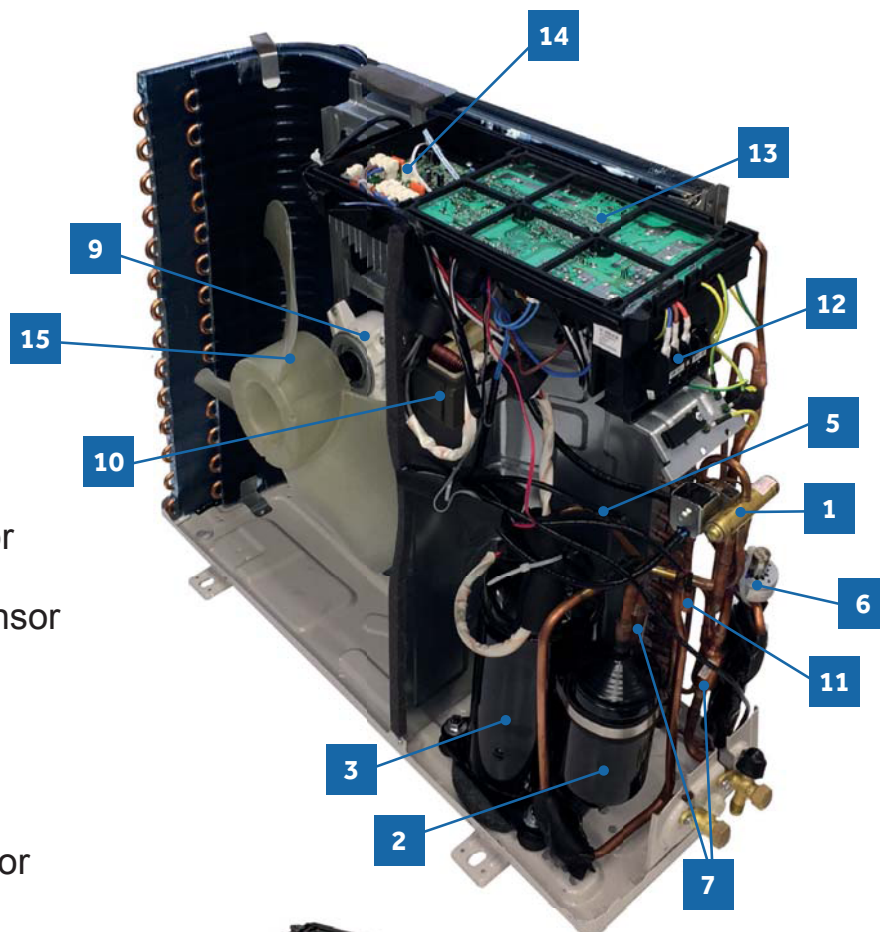

PCB

PCB (1)

- 1 CN1,CN2-Connector for power N and L
- 2 CN3-Connector for ground
- 3 CN22 (09k and 12k), CN23 (18k and 24k) - 5-G-15 VDC connections for power to the IPM
- 4 CN8 and CN9 (09k and 12k), CN9 and CN10 (18k and 24k) - 230 VAC output from the PCB to the IPM
- 5 CN21 (09k and 12k), CN22 (18k and 24k) - Connection for the fan motor
- 6 CN10 (09k and 12k), CN11 (18k and 24k) - 4-way valve connections
- 7 CN18 and CN20 (09k and 12k), CN17, CN21, and CN47 (18k and 24k) - Connectors for thermistors
- 8 CN23 (09k and 12k) and CN24 (18k and 24k) - 5-G-15 VDC communication connection between the PCB and the IPM
- 9 CN24 and CN26 (09k and 12k), CN25 and CN28 (18k and 24k) - 310+ VDC connection from the IPM
- 10 CN4 (09k and 12k) and CN36 (18k and 24k) - Communication connection between the indoor and outdoor units
- 11 CN16 (09k and 12k), CN15 (18k and 24k) - EEV connections
- 12 FUSE 1 (25A, 250V) ; FUSE 2 (3.15A ,250V)
- 13 LED1 - Steady flash indicates normal operation while intermittent flashes are error codes
- 14 RV1,RV2,RV3 ,RV4 Varistor
- 16 CN10-09k and 12k IPM:5-G-15 VDC power from the PCB
- 17 CN11 - Connector for the 5-G-15 VDC communication signal between the PCB and the IPM
- 18 P(CN1), N(CN5)- 310+ VDC power to the PCB
- 19 LI (CN7), LO(CN6) - Power filter reactor connections PCB(3)(Module PCB for 18-24K)
- 20 CN2,CN3,CN4-Connector for the U, V, and W compressor wire connections
- 21 CN10 - 5-G-15 VDC power connection from the PCB
- 22 CN11 - 5-G-15 VDC communication connection with the PCB
- 23 P(CN8), N(CN9)- 310+ VDC power connection to the PCB
- 24 LI (CN3), LO(CN4) power filter reactor
- 25 CN5,CN6,CN7-Compressor U, V, and W wiring connections

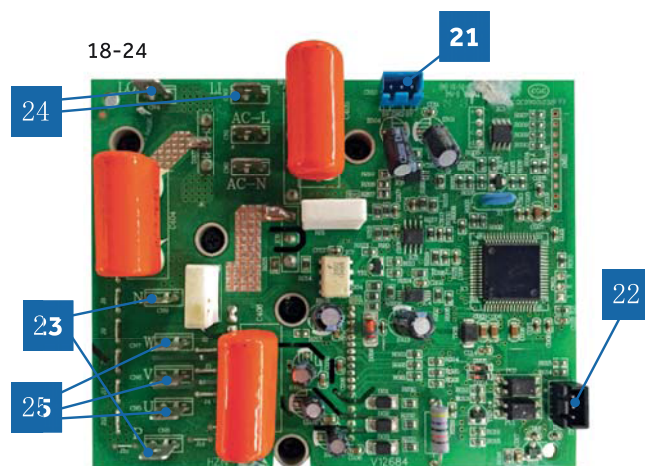
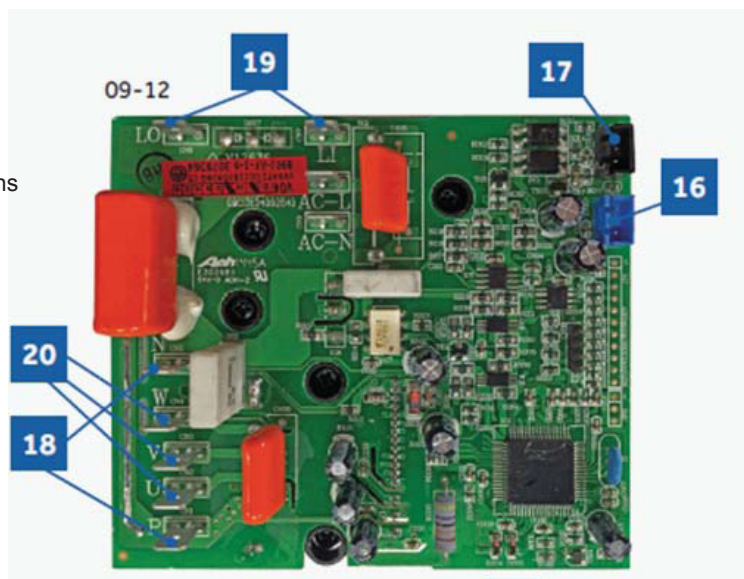
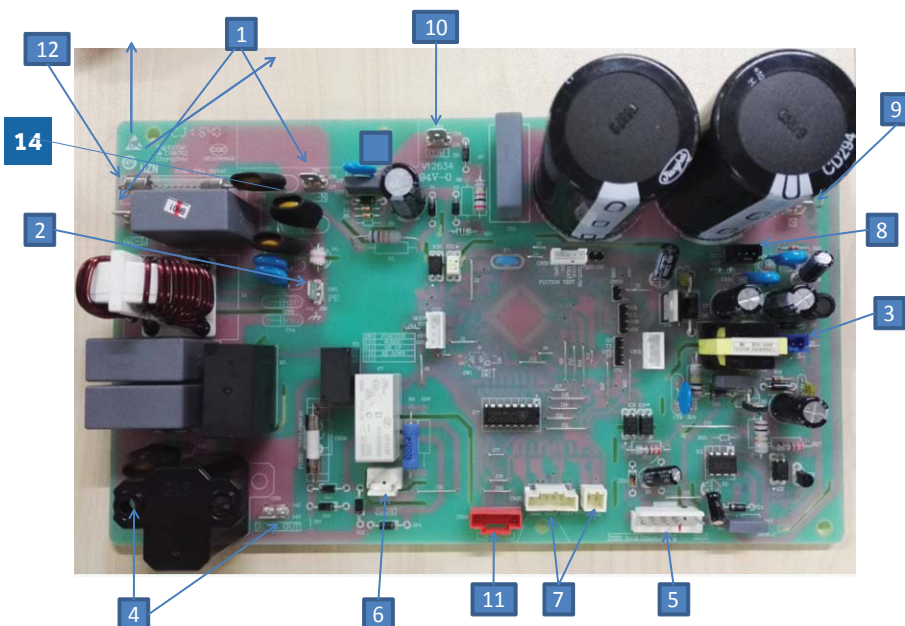

Terminal Block



The 18K and 24K units are 208/230 volt single phase. The 9K and 12K units are 120 volt. All models use terminals 1 and 2 as incoming power wiring. Number 3 is the communication terminal and the 4th terminal is the ground connection. Be sure to match this wiring with the indoor unit terminals.

External accessories such as a condensate overflow switch should break the number 2 (line) terminal.

The indoor unit is powered from the same source as the outdoor section and is connected by using 14/4 AWG copper wire.

There should be no splices in the wiring between the indoor and outdoor unit. Splices may create a loss of communication and generate an E7 error code.

Power Factor Reactor



The Reactor is an inductive filter that will aid in correction of electrical power factor influence of inverter capacitance. It is unlikely to ever have an electrical failure of this component. The Reactor is electrically connected to the IPM on terminals CN6 and CN7 (09k and 12k), or CN3 and CN4 (18k and 24k).

Compressor



The compressor is a three phase DC inverter-driven rotary. The compressor is capable of variable speed operation. The operating frequency will be determined by the difference between set point and room temperature.

The compressor is electrically connected to the Module Board on terminal connections CN-2, CN-3 and CN-4.

The compressor has an internal temperature overload that will open if the compressor becomes too hot. Additional protection of the compressor will be provided by the Compressor Discharge Temperature Sensor and Suction Line Temperature Sensor.

Fan Motor



The fan motor is a variable speed DC motor. The required motor speed is calculated by the Main Control Board. The motor is electrically connected to the PCB via CN21 (09k and 12k), or CN22 (18k and 24k).

In COOL MODE, the motor will slow down as outdoor air temperature falls. In HEAT MODE, the motor will increase speed as the outdoor air temperature falls.

Discharge Temperature Sensor



The Discharge Sensor is a negative coefficient thermistor that senses the temperature of the compressor hot gas. The PCB will make inverter speed changes in response to input from this device.

This sensor connects to the PCB at CN20 (09k and 12k), or CN17 (18k and 24k).

Ambient Temperature Sensor

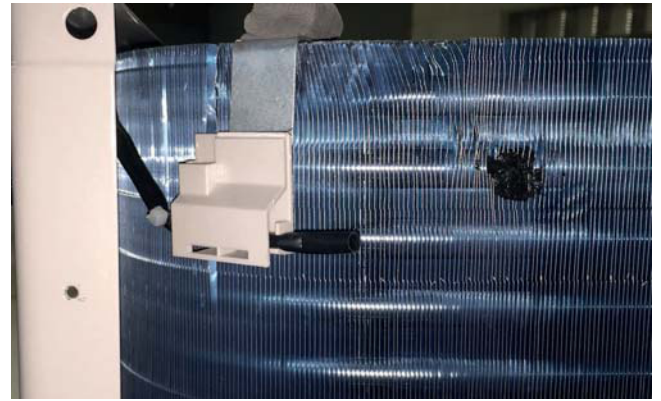

The Ambient Sensor is a negative coefficient thermistor that will change resistance in response to temperature changes. The PCB monitors the temperature of the outdoor air to determine outdoor fan speed requirements and compressor speed. The sensor also plays a role in calculation of required defrost conditions.

This sensor connects to the PCB at CN20 (09k and 12k), or CN19 (18k and 24k).

Defrost Temperature Sensor

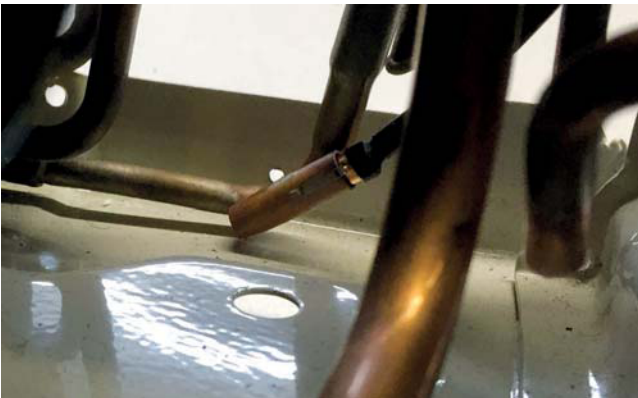

The Defrost Temperature Sensor is a negative coefficient thermistor that will change resistance in response to outdoor coil temperature changes. The Main Control Board monitors the temperature of the outdoor coil to determine when a defrost cycle is necessary. The sensor also monitors outdoor coil temperature during defrost cycles to determine termination conditions.

This sensor connects to the Main Control Board at PLUG CN-20.

Suction Line Temperature Sensor



The Suction Line Temperature Sensor is a negative coefficient thermistor that senses the temperature of the suction line to determine EEV orifice size, maintaining in an attempt to maintain proper operating superheat.

This sensor connects to the PCB at CN18 (09k and 12k), or CN47 (18k and 24k).

4-Way Valve

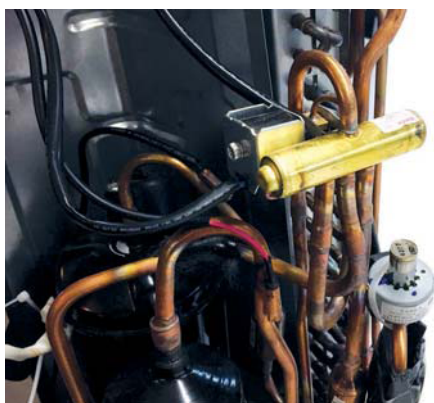

The 4-Way Valve redirects the flow of refrigerant to reverse the functions of the indoor and outdoor coils. When de-energized in COOL MODE, the valve will direct the refrigerant hot gas to the outdoor coil. When energized in HEAT MODE, the valve will direct the hot gas to the indoor coil.

The direction of flow is changed by an electrical solenoid that moves an internal slide mechanism.

The 4-Way Valve is electrically connected to the PCB at CN10 (09k and 12k), or CN11 (18k and 24k).

Electronic Expansion Valve



The valve consists of an electrical operator and a valve body with internal variable size orifice. When operating, the PCB will send pulses of voltage to the electrical operator. The operator will then magnetically move the position of the metering orifice pin to vary the flow of refrigerant.

The pin position is determined from the Suction Line Temperature Sensor input, which will change the flow of refrigerant to maintain proper operating superheat.

During COOL MODE operation, the valve meters low pressure refrigerant to the indoor coil. During HEAT MODE operation, the valve meters low pressure refrigerant to the outdoor coil.

Accumulator



The Accumulator is located in the suction line at the entrance to the compressor. The accumulator helps prevent liquid refrigerant from entering the compressor.

Refrigerant Strainers



The system has debris-catching strainers that protect internal system components from contaminants. The strainer is a permanent part that is not typically replaced.

Table of Contents

Unit Introduction 14
Component Identification 14
Control Board..... 15
Terminal Block..... 16
Display 16
Ambient Temperature Sensor 16
Piping Temperature Sensor 16
Louver Motor 17
Fan Motor 17
Emergency Button 17

Indoor Unit Introduction

The indoor unit is mounted high on the wall to provide conditioned air to the space. Features of the system include: variable speed blower operation that speeds up and slows down with changes in demand, moving louvers to direct air, indoor air temperature sensing, evaporator coil temperature sensing, consumer operation display, evaporator coil with metering device located in outdoor unit, and an emergency operation switch.

Indoor Component Identification

- | | |
|------------------------------|-----------------------------|
| 1 Ambient Temperature Sensor | 5 (PCB) |
| 2 Display | 6 Piping Temperature Sensor |
| 3 Fan Motor | 7 Coil Supply Board |
| 4 Louver Motor | 8 Terminal Block |

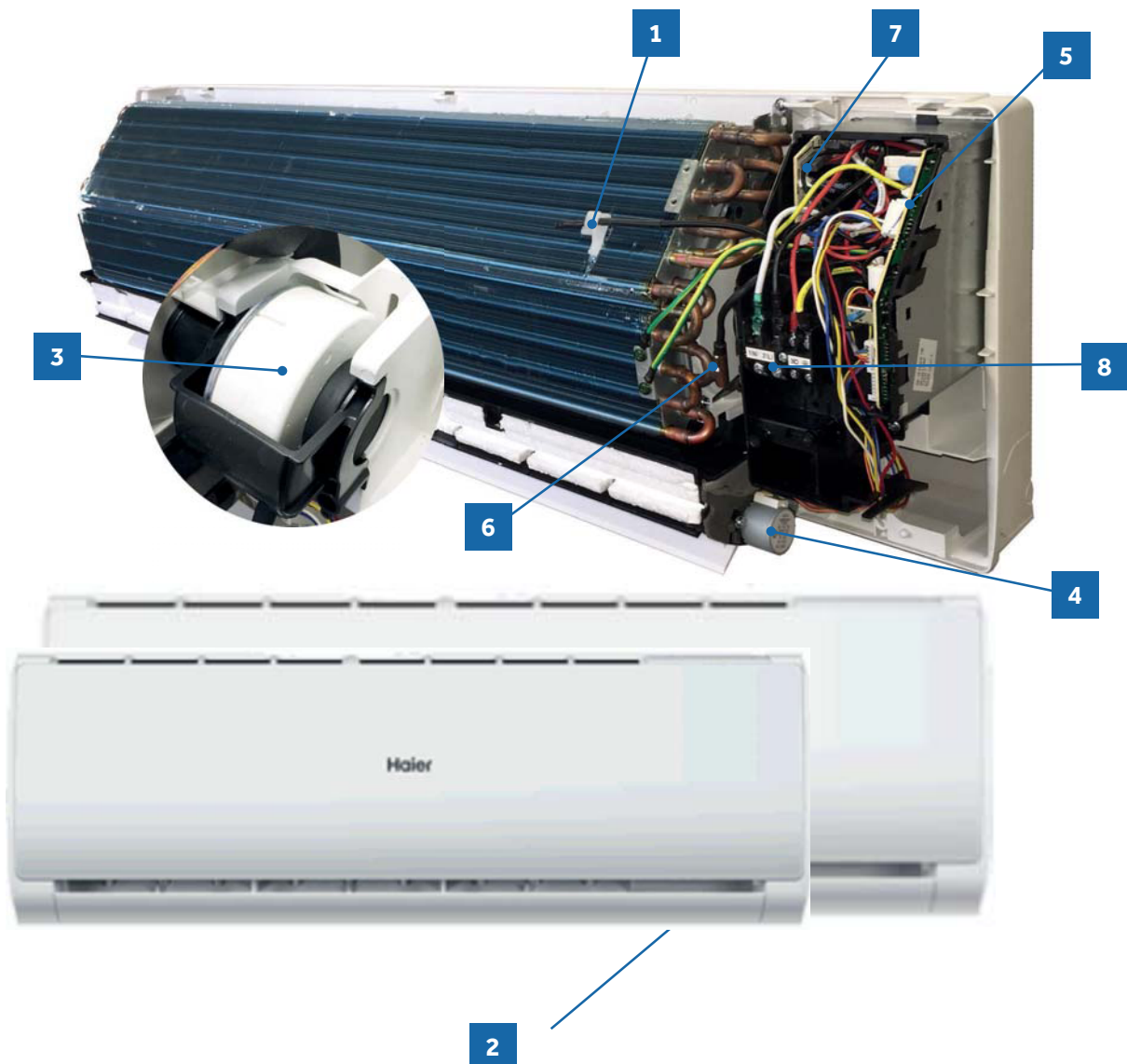

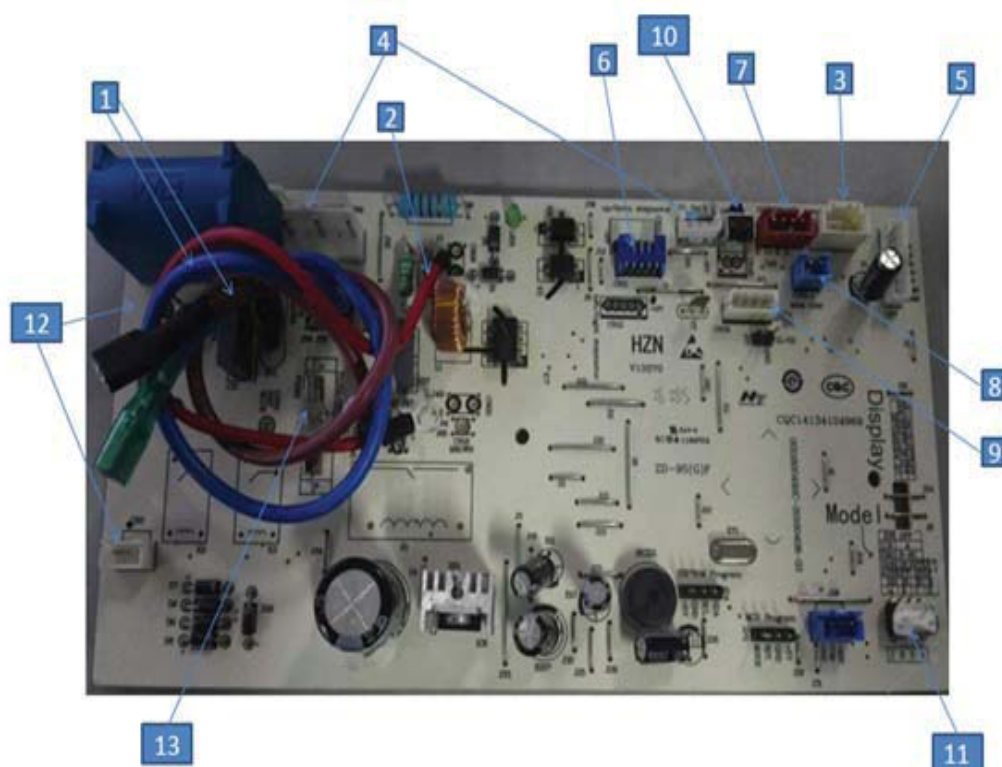

- | | |
|---|---|
| 1 CN21, CN52-Connector for power N and L | 10 SW1- Connector for emergency ON/OFF switch |
| 2 CN23-Connector for communication between indoor and outdoor unit | 11 SW2-1-Select remote code A or B
2-Select enable or disable room card
3,4- Select EEPROM code 22,25,33 or 35 |
| 3 CN6-Connector for thermistors | 12 CN3 and CN1 (09k and 12k) - transformer connection |
| 4 CN8, CN9 (09k and 12k), or CN9 (18k and 24k) - Fan motor connections | 13 FUSE1- Fuse 3.15A/250 VAC |
| 5 CN7- Connector for display | |
| 6 CN11 (09k and 12k), or CN5 (18k and 24k) - Up/down stepper motor connections
CN11 and CN10 (18k and 24k) - Left/right stepper motor connections | |
| 7 CN2-Connector for wired controller | |
| 8 CN51-Connector for room card | |
| 9 CN51 (09k and 12k), or CN34 (18k and 24k) - WiFi connection | |

Terminal Block



The terminal block receives electrical power from the outdoor unit. Terminals 1 and 2 are connected to terminals 1 and 2 of the outdoor unit. This wiring supplies power to the indoor unit.

Terminal 3 is a communication wire. The indoor unit sends indoor air temperature, coil temperature and temperature set point information to the outdoor unit on this wire. If a splice or break in this wire is present, the indoor unit will not be able to communicate with the outdoor unit. The ERROR CODE will be E7.

Display



The indoor display is an infrared communication circuit that receives operating commands from the remote control. This display will indicate operating modes, error codes, indoor air temperature, timer and power status.

Ambient Temperature Sensor



The Ambient Sensor is a negative coefficient thermistor that will decrease in resistance with increases in room air temperature. The sensor is located on a clip mounted to the surface of the indoor coil.

The sensor connects to the control board at Plug CN-6.

Coil Temperature Sensor

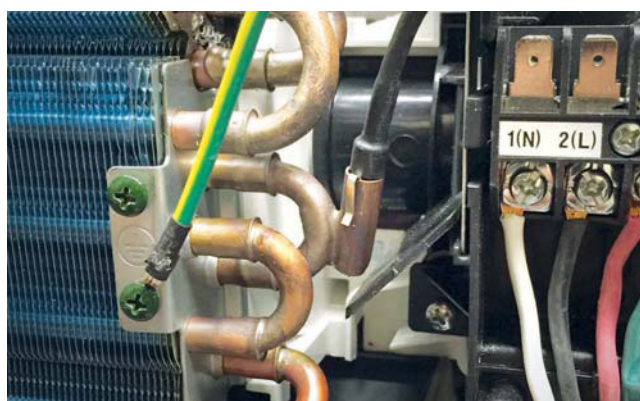

The Coil Sensor is a negative coefficient thermistor that will decrease in resistance with increases in coil temperature. The sensor is located in a socket soldered to the surface of the indoor coil.

This sensor will monitor the temperature of the indoor coil in both cooling and heating. Should abnormally cold or hot coil temperature be detected by this sensor, the system will take steps to correct the condition or report an error code.

The sensor connects to the control board at Plug CN-6.

Stepper Motor and Louver

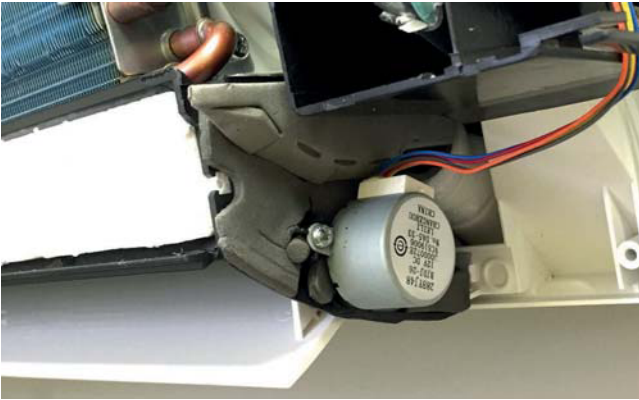

The Stepper Motor moves the louver up and down (09k and 12k), and also right to left (18k and 24k). The motors can be set to move automatically or to several fixed positions.

Fan Motor



The Fan Motor is a variable speed DC motor. The motor will vary speed with the speed of the compressor. It will operate automatically or at a preselected fixed speed. When in AUTO fan mode, the speed of the fan is calculated using the difference between the set and room temperatures.

The fan motor is connected to the PCB at CN8 and CN9 (09k and 12k), or CN9 (18k and 24k).

Emergency Button



If the remote control is non-functional, the Emergency Button can be accessed by swinging open the front of the wall unit. The button is located on the right side.

The system will maintain approximately 75 degrees until the remote is reactivated, or the power is turned off and back on.

DIP Switch

DIP Switch Settings

The PCB for the indoor unit of the Tempo series of single zone mini-splits has a set of DIP switches that must be set when replacing the PCB.

The replacement PCB is shipped with all switches set to the OFF position.

Switch settings:

SW2-1 Selects remote code A or B. Normally set to the off position for code A operation.

If two indoor units are used in the same area and the user wishes to control them separately, switch SW2-1 of the second unit is set to the ON position for code B operation. The wireless remote for the second unit is also set to code B.

SW2-2 Selects room card able or disable.

Normally set to the OFF position. Set to the ON position when used in conjunction with a room card interface utilized in hotel rooms.

SW-3 & SW-4 Selects eeprom code 22, 25, 33 and 35. Set to identify the tonnage of the unit.

Settings:

9K	(22)	SW-3	ON	SW-4	ON
12K	(25)	SW-3	ON	SW-4	OFF
18K	(33)	SW-3	ON	SW-4	OFF
24K	(35)	SW-3	ON	SW-4	ON

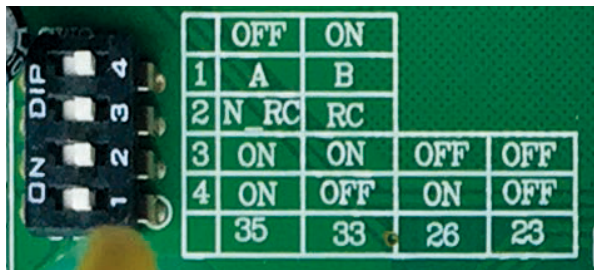

Display Switch Settings

The PCB for the indoor unit of the Tempo series of zone mini-splits has a set of Display switches that must be set when replacing the PCB.

Switch settings:

If two indoor units use different Display, or different PCB, the PCB should switch J1 and J2. J1 set ON, meaning J1 should be connected, J2 set OFF, meaning J2 should be cut.

Settings:

09K	(387)	J1: ON, J2: ON
12K	(387)	J1: ON, J2: ON
18K	(387)	J1: ON, J2: OFF
24K	(387)	J1: ON, J2: OFF

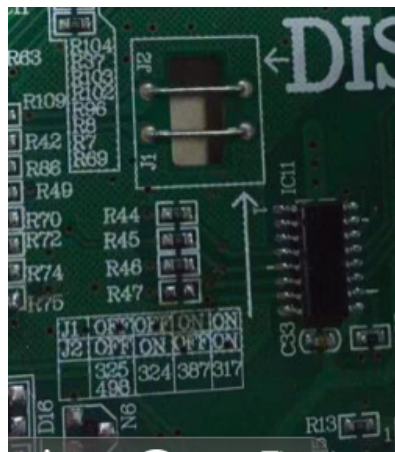

Table of Contents

System Power 20

Cool Mode 20

Overview..... 20

Indoor Unit..... 20

Temperature Sensors..... 20

Communication..... 20

Outdoor Unit..... 20

Temperature Sensors..... 21

Call to Terminate Cooling 21

Freeze Protection..... 21

Heat Mode..... 21

Overview..... 21

Cold Air Proof Operation..... 21

Defrost..... 22

Automatic Heating Temperature Compensation..... 22

Indoor Unit..... 22

Temperature Sensors..... 22

Communication..... 22

Outdoor Unit..... 22

Temperature Sensors..... 22

Call to Terminate Heating 22

Dry Mode 22

Overview..... 22

Indoor Unit..... 23

Temperature Sensors..... 23

Communication..... 23

Outdoor Unit..... 23

Temperature Sensors..... 23

Defrost 23

Protection Functions 23

High Temperature Protection 23

Overheating protection for indoor unit..... 23

Compressor Overcurrent Protection..... 24

Indoor Coil Freeze Protection..... 24

System Power

The 240 VAC power for the system connects to terminals 1(N), 2(L), and ground of the outdoor unit terminal block. This terminal block also connects power to the indoor unit.

The voltage readings between terminals 1(N) and ground, and terminals 2(L) and ground should be 120 VAC. The voltage reading between terminals 1(N) and 2(L) should be 230 VAC.

One additional connection on the terminal block (3) is for the communication wire between the indoor and outdoor units.

NOTE: Mis-wiring of these connections may cause improper operation or damage to system components.

Cool Mode

Overview

The temperature control range in cooling mode is 60°F - 86°F. The temperature set at the remote control and room ambient temperature sensor will determine if a call for cooling is needed. If justified, the call is communicated from the indoor unit to the outdoor unit. The indoor unit louver will open using a stepper motor, and the indoor fan will operate at the speed last set. The outdoor unit will determine the position of the EEV and speed (frequency) of the compressor. There can be a delay of up to 3 minutes before the outdoor unit fan and compressor start.

The speed of the indoor fan can be controlled manually by the user or automatically by the system. The speed can be changed between LOW, MEDIUM, and HIGH. The predetermined conditions for automatic control are as follows: (Tr = room temperature Ts = set temperature)

High Speed: $Tr \leq Ts + 5.4^{\circ}\text{F}$

Medium Speed: $Ts + 1.8^{\circ}\text{F} \leq Tr < Ts + 5.4^{\circ}\text{F}$

Low Speed: $Tr \leq Ts + 1.8^{\circ}\text{F}$ or when the sensor is off.

There will be a 2 second delay when manually controlling the speed.

The outdoor unit temperature sensors; outdoor ambient, defrost, suction line, and compressor discharge, used in conjunction with the indoor temperature sensors (ambient and coil), provide information to the outdoor control board to monitor the system and regulate the frequency of the compressor, EEV positioning, and outdoor fan speed to achieve the desired room temperature.

When cooling has been satisfied, the compressor will turn off, followed by the outdoor fan. The indoor unit fan will continue to run.

If the system detects a malfunction, it may shut down, or show an error code on the indoor unit display board and/or outdoor PCB.

Indoor Unit

To enter the cool mode, point the infrared remote control at the indoor unit, press the power button, then press the COOL button if not already set.

The indoor unit main board will activate the display. The PCB will illuminate the display, indicating the temperature and current unit status.

The indoor unit main board will signal the louver stepper motor to open the louver to either a stationary position, or one of several oscillating modes.

As the louver opens, the main board will power up the fan motor, operating the fan at the speed last set. The motor has a feedback circuit which provides the main board with information for controlling the speed of the fan motor.

Temperature Sensors

Ambient (room) and coil temperature sensors are used to control the system in the cooling mode. The resistance values of the sensors will vary with temperature. Values can be found using a temperature / resistance chart specific to the sensor being checked.

Communication

The indoor and outdoor unit main boards communicate via a digital signal on the wire connected to Terminal 3 of each unit. A splice or break in this wire will cause a communication error.

Outdoor Unit

Upon a request for cooling, the PCB applies power to the outdoor fan motor and compressor. Depending on system cycling, there may be up to a 3 minute wait before the compressor and outdoor fan start.

WARNING: Do not measure compressor voltages as damage to the meter may result.

If the room temperature is less than the set temperature, yet higher than 2°F below the set temperature, the system will adjust the running frequency of the compressor automatically.

The PCB also controls the position of the EEV (Electronic Expansion Valve) to regulate the flow of refrigerant to the evaporator coil.

Temperature Sensors

Four temperature sensors provide temperature information to the PCB for control of the system.

The ambient sensor provides the temperature of the air drawn into the condenser coil of the outdoor unit.

The defrost sensor provides the temperature sensed at the output of the condenser coil.

The suction line sensor provides the temperature sensed at the incoming suction line pipe.

The compressor discharge sensor provides the temperature sensed at the discharge pipe of the compressor.

Call to Terminate Cooling

The system will terminate cooling when the room temperature is not more than two degrees below the set temperature. The compressor stops, while the outdoor fan continues running for another 60 seconds.

The indoor fan motor and louver will continue operating after cooling has been terminated.

To stop cool mode, press the power button to turn the system off, or change to another mode.

Freeze Protection

To prevent the indoor coil from becoming too cold during low load or high humidity days, and when the compressor has been running for 10 seconds with the coil temperature at or below 32 degrees, the compressor will stop automatically. The indoor fan will continue to run, using room air to warm the coil. When the coil temperature has reached 45 degrees for 3 minutes or more, the compressor will start to resume the cooling operation.

The temperature control range in heating mode is 60°F - 86°F.

Heat Mode

Overview

The temperature set at the remote control and the room ambient temperature sensor will determine if a call for heat is needed. If justified, a temperature compensation adjustment is automatically added to the

operating parameter and the call is communicated from the indoor unit to the outdoor unit.

The louver will open using a stepper motor. The indoor fan will not operate until the coil warms sufficiently to keep cold air from circulating in the room.

The outdoor unit will shift the 4-way valve to the heating and determine the position of the EEV and speed (frequency) of the compressor. There can be a delay of up to 3 minutes before the outdoor fan and compressor start.

(T_r = room temperature T_s = set temperature)

If $T_r \leq T_s$, the outdoor unit will operate and the indoor fan operates in cold air proof operation

If $T_r > T_s + 4^\circ\text{F}$, the outdoor unit turns off and the indoor fan will circulate any residual heat remaining in the coil.

If $T_r < T_s + 4^\circ\text{F}$, the outdoor unit will restart and the indoor fan operates in cold air proof operation.

The speed of the indoor fan can be controlled manually by the user or automatically by the system. The speed can be changed between HIGH, MEDIUM, and LOW. The predetermined conditions for automatic control are as follows:

High Speed: $T_r < T_s$

Medium Speed: $T_s \leq T_r \leq T_s + 4^\circ\text{F}$

Low Speed: $T_r > T_s + 4^\circ\text{F}$

Cold Air Proof Operation

At initial start of heat mode, indoor blower will not be turned on until the coil has reached a minimum temperature. This delay period can be up to 3 minutes, depending on the difference between the room and the set temperature.

This period usually takes 30 seconds to 3 minutes depending on the outdoor ambient temperature.

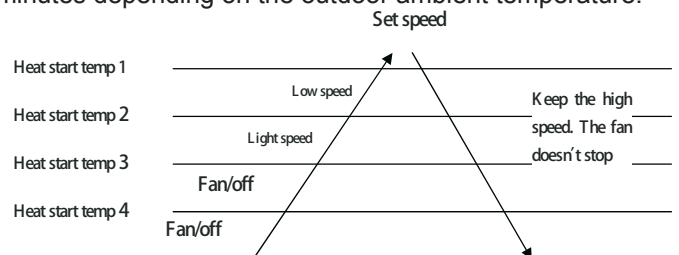

The outdoor unit sensors; ambient, defrost, suction line, and compressor discharge, used in conjunction with the indoor sensors,

ambient and coil, provide information to the outdoor control board to monitor the coil and regulate the frequency of the compressor, EEV positioning, and outdoor fan speed to achieve the desired room temperature.

When heating has been satisfied, the outdoor unit compressor will turn off first and followed by the outdoor fan. The 4-way valve will de-energize 2 minutes after the compressor stops.

The indoor unit fan will continue to run at a very low speed until any heat remaining in the coil is circulated into the room.

If the system detects a malfunction, it may shut down or show an error code on the indoor unit display board and/or outdoor unit main board LED.

Defrost

When the system initiates a call for defrost, the indoor fan motor stops. The indoor unit display will not change. The system will cycle through the defrost operation. Any indoor unit malfunctions will be ignored until the compressor restarts and has been operating for 30 seconds. At the conclusion of the defrost cycle, the indoor fan will enter the cold air proof operation and heating resumes.

Indoor Unit

To enter the heat mode, point the infrared remote controller at the unit and press the power button, then press the HEAT mode button if not already set.

The PCB will illuminate the display, indicating the temperature and current status.

The louver stepper motor to open the louver to a stationary position.

The louver opens to the lowest downward position, then the fan motor starts after the coil has warmed to a sufficient temperature (cold air proof operation). The PCB sends the motor information to monitor the speed if in the AUTO mode, or returns the motor to the fixed speed set previously.

Temperature Sensors

The room (ambient) and coil sensors are used to maintain the system at the temperature desired. The resistance values of the sensors can be verified using the temperature-to-resistance charts found in this manual.

Communication

The indoor and outdoor units main boards communicate via the wire connected to terminal 3 of each unit. A splice or break in this wire will cause a communication error.

Outdoor Unit

Upon a request for heat, the PCB applies power to the 4-way valve, outdoor fan motor, and compressor. Depending on system cycling, there may be up to a 3 minute wait period before the compressor and outdoor fan start.

NOTE: Do not measure compressor voltages, damage to the meter may result.

If the room temperature is above the set temperature, yet lower than 2°F above the set temperature, the system will adjust the running frequency of the compressor automatically.

The PCB also controls the position of the EEV (Electronic Expansion Valve) to regulate the flow of refrigerant to the indoor unit evaporator coil.

Temperature Sensors

Four sensors provide temperature information to the main board for control of the system during heat mode.

The ambient sensor provides the temperature of the air drawn into the evaporator coil.

The defrost temperature sensor provides the temperature sensed at the output of the evaporator coil.

The suction line sensor provides the temperature sensed at the incoming suction line pipe.

The compressor discharge sensor provides the temperature sensed at the discharge pipe of the compressor.

Call to Terminate Heating

The system will call to terminate heating when the temperature is equal to or higher than 2°F above the set temperature.

The PCB will de-energize the compressor. The outdoor fan will run for 60 seconds before stopping, and the 4-way valve will de-energize 2 minutes after the compressor stops.

To stop heat mode, press the power button to turn the system off, or change to another mode.

Dry Mode

Overview

Dry mode helps remove excess moisture from the room during periods of high humidity.

(Tr = room temperature Ts = set temperature)

When $Tr > Ts + 4^{\circ}F$, the compressor will turn on and the indoor fan will operate at the set speed.

When $Ts \leq Tr \leq Ts + 4^{\circ}F$, the compressor will operate at the high dry frequency for 10 minutes, then at the HIGH DRY and LOW DRY mode for 6 minutes. The indoor fan will operate at LOW speed. When $Tr < Ts$, the outdoor unit will stop, and the indoor fan will stop for 3 minutes, then operate at the LOW speed option.

Automatic fan speed:

When $Tr \geq Ts + 9^{\circ}F$, HIGH speed

When $Ts + 5.4^{\circ}F \leq Tr < Ts + 9^{\circ}F$, MEDIUM speed

When $Ts + 3.6^{\circ}F \leq Tr < Ts + 5.4^{\circ}F$, LOW speed

When $Tr < Ts + 3.6^{\circ}F$, Light speed

Note: TURBO and QUIET mode must be set using the remote controller.

If the outdoor fan is stopped, the indoor fan will pause for 3 minutes. If the outdoor fan is stopped for more than 3 minutes, and the compressor is still operating, the indoor fan will change to low speed mode.

Indoor Unit

The PCB will signal the louver stepper motor to open the to either a stationary position or one of several oscillating modes.

As the louver opens, the PCB will power up the fan motor, The PCB controls the fan speed if set to the Auto position, or signals the motor to operate at a fixed speed previously set.the speed of the fan motor.

Temperature Sensors

Use same language here as used in the heating section, inserting dry mode in place of heat or heating.

Communication

The indoor and outdoor unit units communicate via the wire connected to terminal 3 of each unit.A splice or break in this wire will cause a communication error.

Outdoor Unit

Upon a request for dry mode, the PCB applies power to the fan motor outdoor and compressor.Depending on system cycling, there may be up to a 3 minute wait period before the compressor and outdoor fan start.

WARNING: Do not measure compressor voltages as damage to the meter may result.

The PCB also controls the position of the EEV (Electronic Expansion Valve) to regulate the flow of refrigerant to the evaporator coil.

Temperature Sensors

Four sensors provide temperature information to the PCB for control of the system during dry mode.

The ambient sensor provides the temperature of the air drawn into the condenser coil of the outdoor unit.

The defrost sensor provides the temperature sensed at the output of the condenser coil.

The suction line sensor provides the temperature sensed at the incoming suction line pipe.

The discharge sensor provides the temperature sensed at the discharge pipe of the compressor.

To stop dry mode, press the power button to turn the system off, or change to another mode.

Defrost

The PCB monitors the temperature difference between the ambient and defrost sensors as the coil becomes colder. A defrost cycle will initiate when this difference grows beyond an acceptable level. To enter a defrost cycle, the compressor must have accumulated 10 minutes of run time and 45 minutes of run time since the last defrost.

When a call for defrost initiates, the compressor slowly ramps down, then runs for 30 seconds at a very low speed.

1 minute from the call for defrost, the 4WV switches to cooling, all fans stop, and the EEV changes to a mid-range. Once these functions are completed, the compressor ramps up to a high speed.

When the outdoor coil reaches more than 45 degrees for 60 seconds, or more than 54 degrees for 30 seconds, the defrost cycle will terminate. The compressor then returns to a very low speed for 1 minute while all components return to the heating mode.

The defrost cycle is terminated automatically after 10 minutes if the coil does not reach the specified temperatures.

Protection Functions

1. High Temperature

The discharge (exhaust) sensor monitors the temperature of the refrigerant leaving the compressor. Compressor speed will either increase, decrease, or the compressor may stop in response to temperatures reported by the discharge sensor. Refer to the table below.

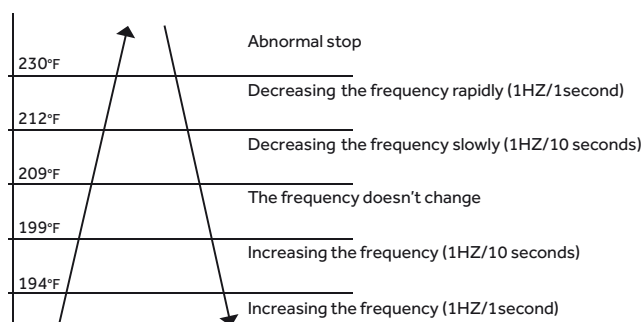

2. Overheating protection for indoor unit

coil sensor monitors temperature at the coil surface according to the table below.

Overheating protection for indoor unit					
	Increasing slowly	Prohibiting increasing	Decreasing slowly	Decreasing rapidly	Compressor stop
09K	48°C/118°F	51°C/124°F	56°C/133°F	59°C/138°F	63°C/145°F
12K	48°C/118°F	51°C/124°F	56°C/133°F	59°C/138°F	63°C/145°F
18K	48°C/118°F	53°C/127°F	56°C/133°F	60°C/140°F	63°C/145°F
24K	48°C/118°F	53°C/127°F	56°C/133°F	60°C/140°F	63°C/145°F

3. Compressor Overcurrent Protection

If the current draw of the compressor at start-up is greater than the values in the chart below for approximately 3 seconds, the compressor will stop and a code will be indicated at the outdoor unit. After 3 minutes the compressor will restart. If the overcurrent condition occurs 3 times in 20 minutes, the system will lock out. It will be necessary to remove power to the system to reset the lock out condition.

Current overload protection				
	No charge	Decrease 1Hz/10s	Decrease 1Hz/s	Over Current Point
09K	12A	13A	14A	15A
12K	13A	14A	15A	17A
18K	13A	13.5A	14.5A	15.5A
24K	17A	18A	19A	20A

4. Indoor Coil Freeze Protection

The coil sensor protects the coil from becoming too cold during low cooling load days or periods of high humidity.

Tpg_indoor: indoor unit pipe sensor temperature

When Tpg_indoor < Tpg1, the frequency of the compressor decreases at the rate of 1HZ / 1 second.

When Tpg_indoor < Tpg2, the frequency of the compressor decreases at the rate of 10HZ / 10 seconds.

When Tpg_indoor begins to rise again, and Tpg2 ≤ Tpg_indoor ≤ Tpg3, the frequency of the compressor does not change.

When Tpg3 < Tpg_indoor < Tpg4, the frequency of the compressor increases at the rate of 1HZ / 10 seconds.

Example: if Tpg_indoor ≤ 32°F sustains for 2 minutes, the outdoor unit will stop and indicate an underload malfunction code at the outdoor unit. The compressor stops for a minimum of 3 minutes. When Tpg_indoor > Tpg4, the compressor will restart.

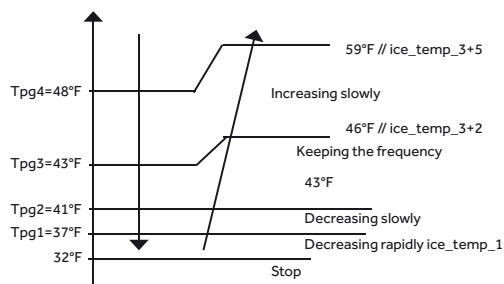

System Specifications

Model Name	System	09TE	12TE	18TE	24TE
	Outdoor	1U09TE1VHA	1U12TE1VHA	1U18TE2VHA	1U24TE2VHA
	Indoor	AW09TE1VHA	AW12TE1VHA	AW18TE2VHA	AW24TE2VHA
Cooling	Rated Capacity <i>Btu/hr</i>	9,000	12,000	18,000	24,000
	Capacity Range <i>Btu/hr</i>	3,800~12,000	4,100~12,500	5,000~19,000	6,500~26,000
	Rated Power Input <i>W</i>	810	1,200	1,650	2,150
	SEER	16	16	16	16
	EER	11.0	11.0	10.0	10.0
	Moisture Removal <i>Pt./h</i>	2.50	3.40	4.20	5.90
Heating	Rated Heating Capacity 47°F <i>Btu/h</i>	10,000	12,000	19,000	26,000
	Heating Capacity Range <i>Btu/hr</i>	4,100~12,000	4,500~16,000	5,400~22,000	6,800~28,000
	Rated Power Input <i>W</i>	850	1,000	1,700	2,400
	HSPF	9.0	9.0	9.0	9.0
	Rated Heating Capacity 17°F <i>Btu/h</i>	5,600	7,800	11,200	16,600
	Max. Heating Capacity 17°F <i>Btu/h</i>	8,200	10,000	15,500	19,300
	Heating Capacity 5°F <i>Btu/hr</i>	6,600	8,000	12,400	15,500
Heating Capacity -4°F <i>Btu/hr</i>	5,100	6,200	9,500	12,900	
Operating Range	Cooling °F(°C)	14°F~115°F(-10~46°C)	14°F~115°F(-10~46°C)	0°F~115°F(-18~46°C)	0°F~115°F(-18~46°C)
	Heating °F(°C)	-4°F~75°F (-20~24°C)	-4°F~75°F (-20~24°C)	-4°F~75°F (-20~24°C)	-4°F~75°F (-20~24°C)
Power Supply	Voltage, Cycle, Phase <i>V/Hz/-</i>	115/60/1	115/60/1	208-230/60/1	208-230/60/1
Outdoor Unit	Compressor Type	DC Inverter Driven Rotary			
	Maximum Fuse Size <i>A</i>	20	20	20	25
	Minimum Circuit Amp <i>A</i>	18	18	17	19
	Outdoor Fan Speed <i>RPM</i>	850	850	800	800
	Outdoor Noise Level <i>dB</i>	47	50	56	53
	Dimension: Height <i>in (mm)</i>	21 1/4(540)	21 1/4(540)	27 7/16 (697)	30 (762)
	Dimension: Width <i>in (mm)</i>	30 11/16(780)	30 11/16(780)	35 (890)	36 3/16 (920)
	Dimension: Depth <i>in (mm)</i>	9 5/8(245)	9 5/8(245)	13 7/8 (353)	15 1/8 (385)
	Weight (Ship/Net)- <i>lbs (kg)</i>	66.2/58.4(30/26.5)	71.7/63.9(32.5/29)	105.8/97.0(48.0/44.0)	121.3/112.5(55.0/51.0)
Indoor Unit	Fan Speed Stages	5 + Auto	5 + Auto	5 + Auto	5 + Auto
	Airflow (Turbo/High/Med/Low/Quiet) <i>CFM</i>	305/295/280/265/240	310/300/287/275/245	545/530/505/475/460	665/650/610/570/555
	Motor Speed (Turbo/High/Med/Low/Quiet) <i>RPM</i>	1150/1050/950/850/750	1200/1100/1000/900/800	1150/1100/1000/900/850	1250/1200/1050/900/850
	Indoor Sound Level <i>dB</i> (Turbo/High/Med/Low/Quiet)	39-23	39-23	45-33	47-34
	Dimension: Height <i>in (mm)</i>	11 7/16(290)	11 7/16(290)	12 1/2(318)	13 3/16(335)
	Dimension: Width <i>in (mm)</i>	34(864)	34(864)	39 11/16(1008)	44 5/16(1125)
	Dimension: Depth <i>in (mm)</i>	7 7/8(200)	7 7/8(200)	8 7/8(225)	9 7/16(240)
	Weight (Ship/Net)- <i>lbs (kg)</i>	24.7/19.9(11.2/9.0)	24.7/19.9(11.2/9.0)	33.1/26.5(15.0/12.0)	38.6/30.9(17.5/14.0)
Refrigerant Lines	Connections	Flare	Flare	Flare	Flare
	Liquid O.D. <i>in</i>	1/4	1/4	1/4	1/4
	Suction O.D. <i>in</i>	3/8	3/8	1/2	1/2
	Factory Charge <i>Oz</i>	26.5	35.3	40.6	67.0
	Maximum Line Length <i>Ft / m</i>	66/20	66/20	83/25	83/25
	Maximum Height <i>Ft / m</i>	33/10	33/10	50/15	50/15

[This page intentionally left blank.]

Table of Contents

Check This First Outdoor Unit29
 Check This First Indoor Unit30
 Wiring Diagram Reference.....31
 Error Code (Indoor/outdoor)
 F1/LED1: 2 Flash32
 F2/LED1: 24 Flash34
 F3/LED1: 4 Flash36
 F4/LED1: 8 Flash38
 F6/LED1: 12 Flash
 F7/LED1: 11 Flash
 F21/LED1: 10 Flash
 F25/LED1: 13 Flash
 E1/LED1: No Flash
 E2/LED1: No Flash40
 F6/LED1: 12 Flash, F7/LED1: 11 Flash, F21/LED1: 10 Flash, F25/LED1: 13 Flash,
 E1/LED1: No Flash, E2/LED1: No Flash41
 F8/LED1: 9 Flash42
 F11/LED1: 18 Flash44
 F12/LED1: 1 Flash46
 E5/LED1: 22 Flash.....47
 E7/LED1: 15 Flash49
 Error Code (Indoor)
 E1452
 Checking System Components.....54

Conditions Needed for Basic Operation

Check This First

Outdoor Unit

Models:

- ASH109CRAWA
- ASH112CRAWA
- ASH118CRDWA
- ASH124CRDWA

3-minutes of time delay from the call for heating or cooling

Line voltage available at:

1. TERMINAL STRIP - 1(N) & 2 (L)
2. AC-L & AC-N at the PCB - CN2 & CN1
3. AC-L OUT & AC-N OUT at the PCB - CN8 & CN9
4. AC-L & AC-N at the IPM - CN8 & CN9 (9K) / CN1 & CN2 (12K/18K)

- 1 (N) and 3 (C): 0-80 VAC fluctuating
- 2 (L) and 3 (C): 0-140 VAC fluctuating

310+ VDC available at:

1. P & N at the IPM - CN1 & CN5 (9K) / CN8 & CN9 (12K/18K)
2. P & N at the PCB - CN24 & CN26

Module COM 5-G-15 VDC available at:

1. CN23 at the PCB
2. CN11 at the IPM

Module power 5-G-15 VDC available at:

1. CN22 AT THE PCB
2. CN10 AT THE IPM

Wiring Diagram Reference

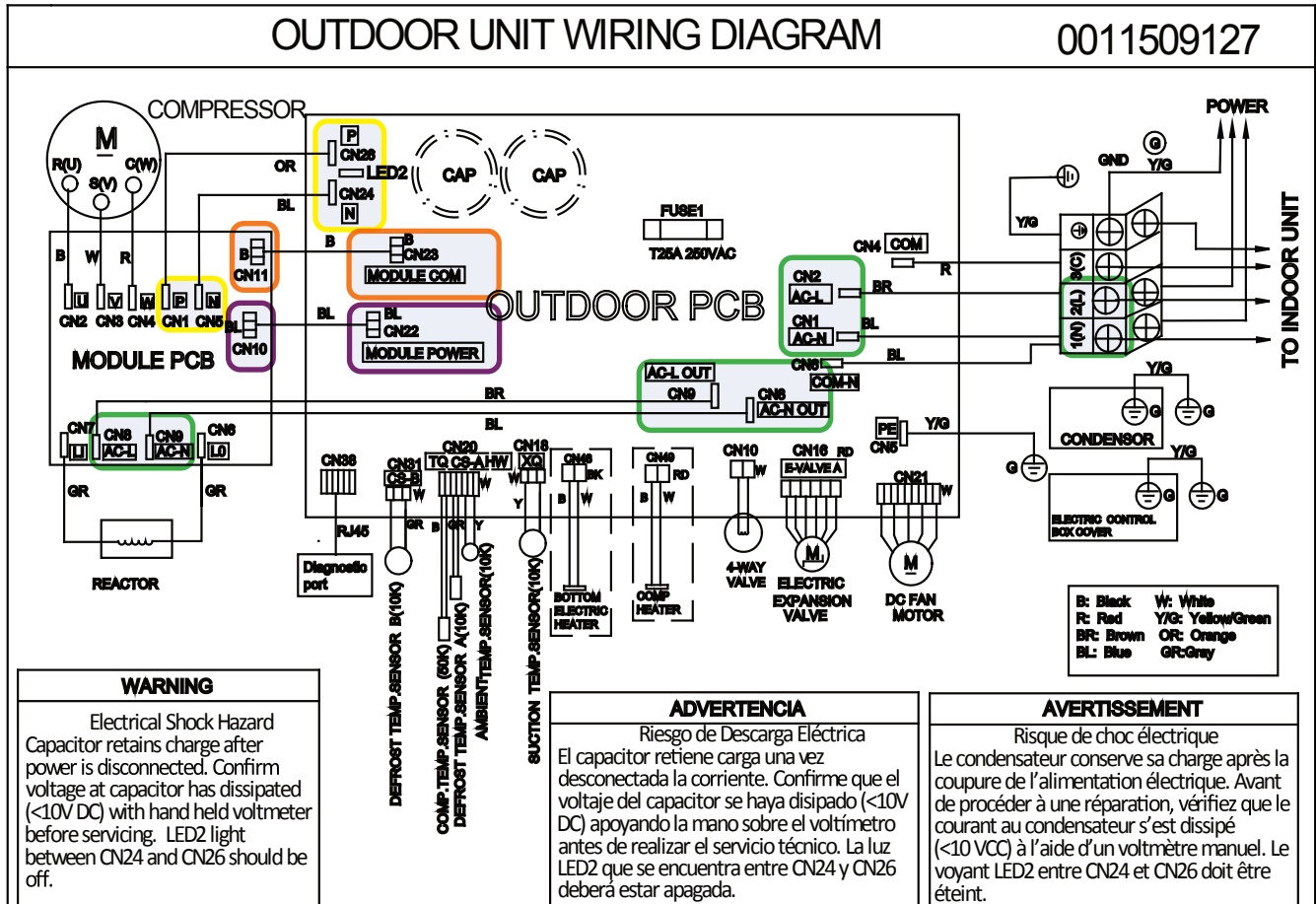

Check This First Indoor Unit

Models:

ASYW09CRAWA
ASYW12CRAWA
ASYW18CRDWA
ASYW24CRDWA

See reverse side for wiring diagram and relevant color-coded test positions.

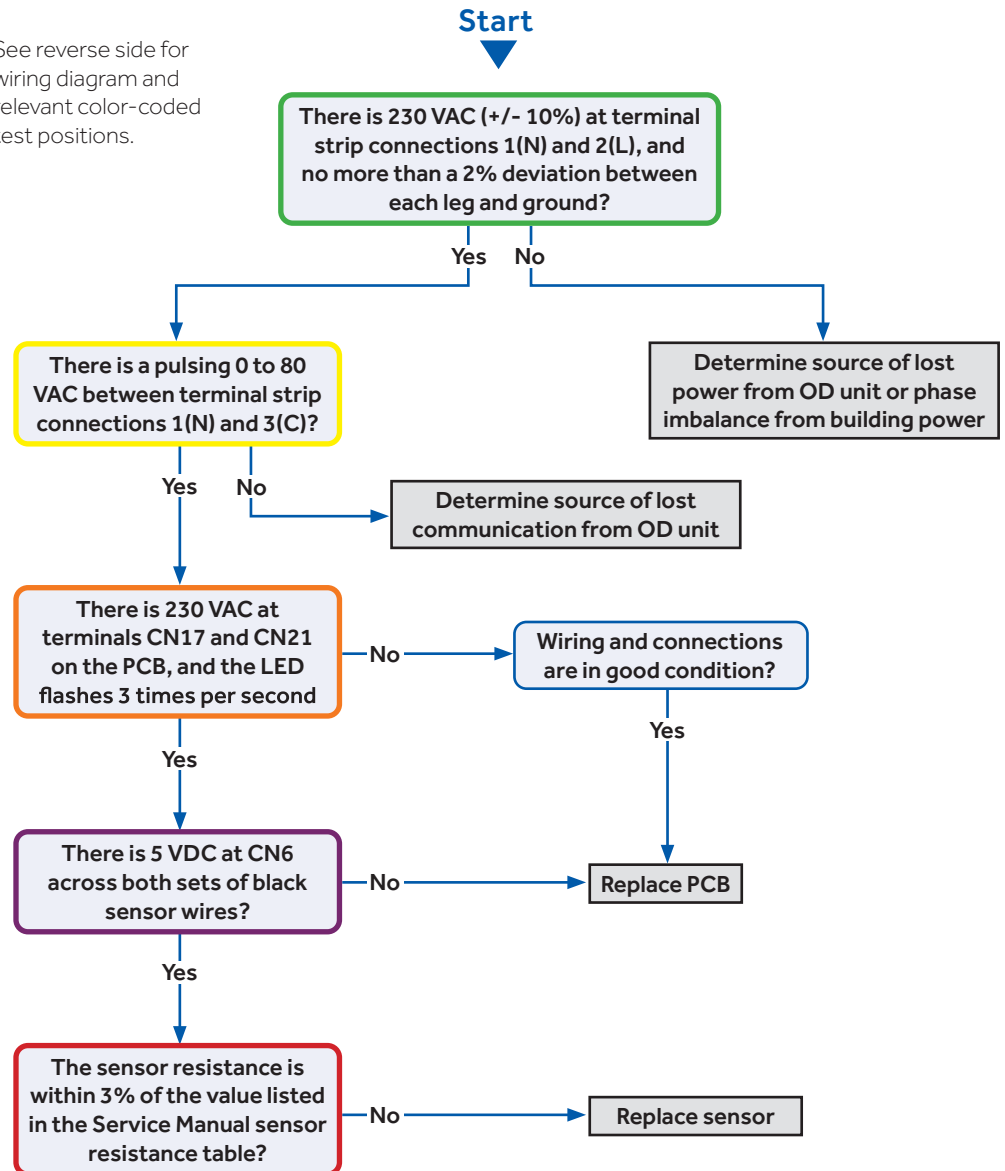

Troubleshooting

Check This First - Indoor Unit

Wiring Diagram Reference

Sensor Resistance Table

°F	°C	Normal (KΩ)		
		10K SENSORS	23K SENSORS	50K SENSORS
-0.4	-18	75.44	235.90	5494.21
5.0	-15	64.30	196.61	4558.19
10.4	-12	54.99	164.40	3795.39
14.0	-10	49.62	146.15	3365.73
21.2	-6	40.58	115.95	2658.81
24.8	-4	36.77	103.46	2368.32
32.0	0	30.30	82.69	1887.00
35.6	2	27.55	74.07	1687.81
41.0	5	23.95	62.94	1431.28
44.6	7	21.84	56.57	1284.36
50.0	10	19.06	48.31	1094.32
55.4	13	16.68	41.40	934.94
59.0	15	15.28	37.41	843.05
64.4	18	13.42	32.22	723.41
69.8	21	11.81	27.83	622.32
75.2	24	10.42	24.11	536.65
77.0	25	10.00	23.00	511.08
80.6	27	9.21	20.95	464.05
86.0	30	8.16	18.25	402.24
89.6	32	7.54	16.67	366.13
95.0	35	6.70	14.59	318.52
100.4	38	5.97	12.79	277.70

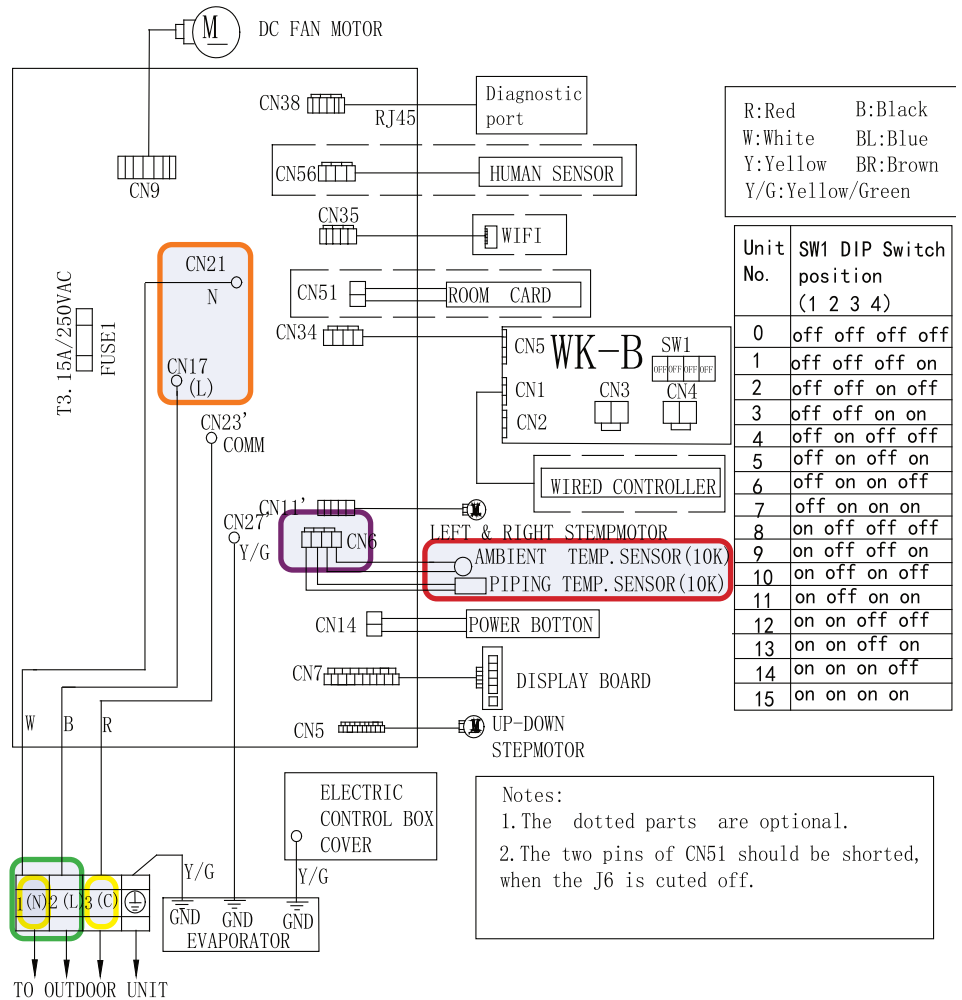

R:Red B:Black
W:White BL:Blue
Y:Yellow BR:Brown
Y/G:Yellow/Green

Unit No.	SW1 DIP Switch position (1 2 3 4)
0	off off off off
1	off off off on
2	off off on off
3	off off on on
4	off on off off
5	off on off on
6	off on on off
7	off on on on
8	on off off off
9	on off off on
10	on off on off
11	on off on on
12	on on off off
13	on on off on
14	on on on off
15	on on on on

Notes:
1. The dotted parts are optional.
2. The two pins of CN51 should be shorted, when the J6 is cuted off.

Model selection:
09K model-23 code - BM1 - 1 off 2 off
12K model-26 code - BM1 - 1 off 2 on
18K model-33 code - BM1 - 1 on 2 off

Notes: Before replacing the board, it is necessary to ensure that the machine is matched with the board code

Troubleshooting

Error Code (Indoor/Outdoor)

F1/LED1: 2 Flash

IPM Power Module Fail
(IPM power module protection)

Complete the "Check This First" Flow Chart before continuing.

Models:

ASYW09CRAWA
ASYW12CRAWA
ASYW18CRDWA
ASYW24CRDWA

ASH109CRAWA
ASH112CRAWA
ASH118CRAWA
ASH124CRAWA

See reverse side for wiring diagram and relevant color-coded test positions.

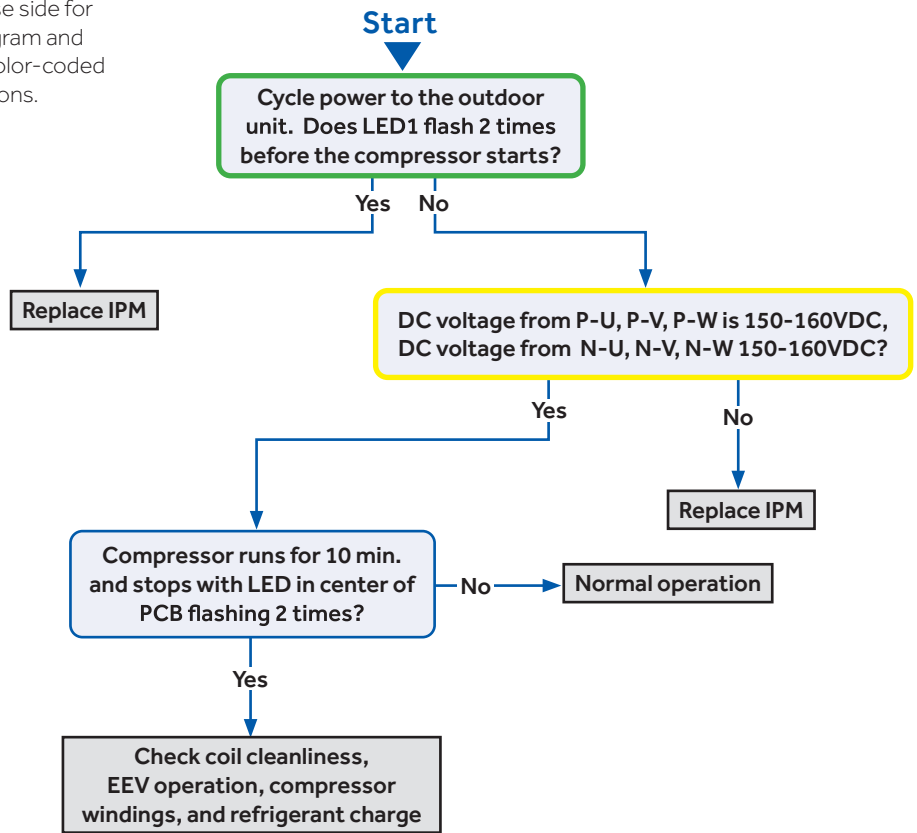

Troubleshooting

Error Code: F1/LED1: 2 Flash

Wiring Diagram Reference

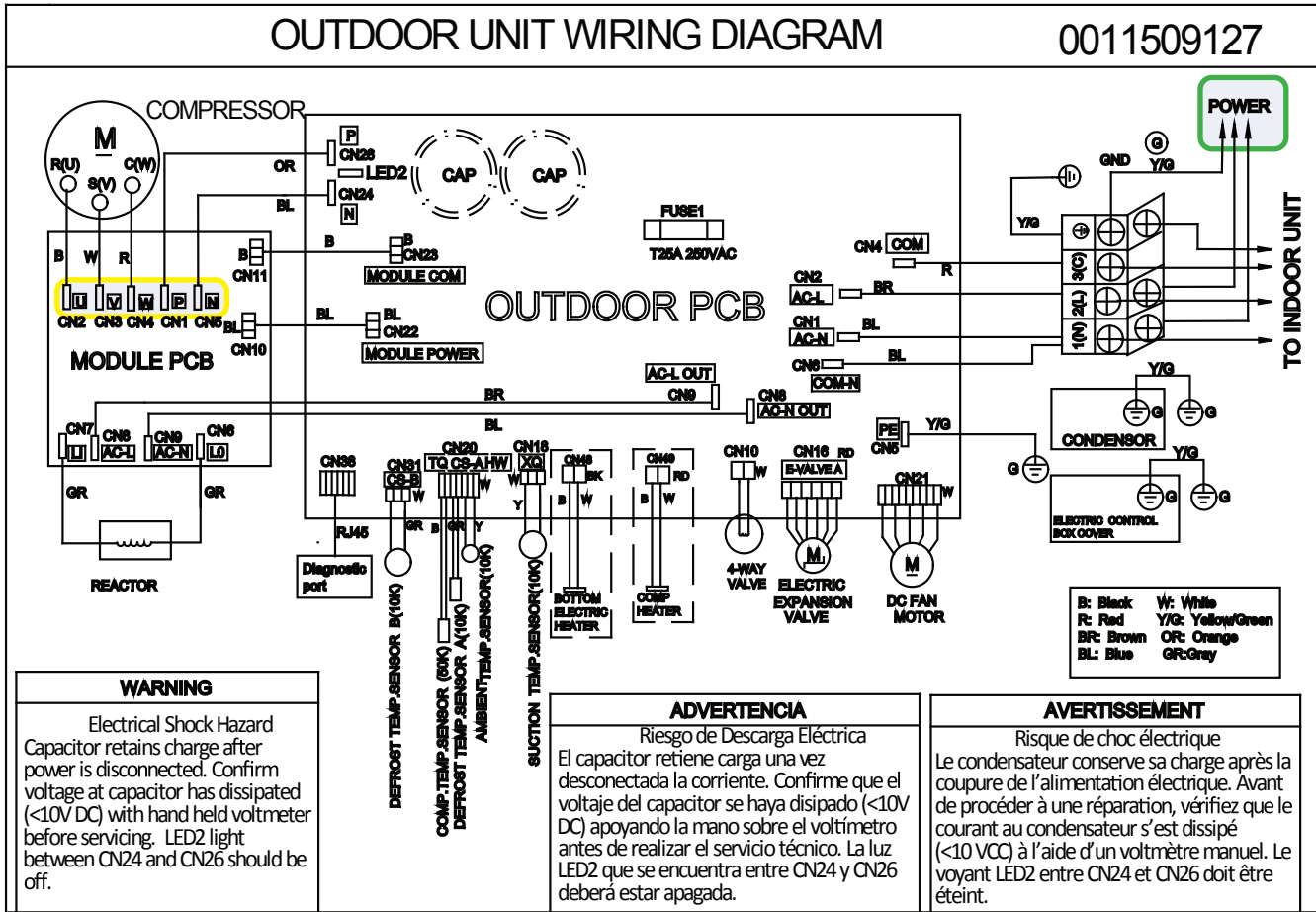

EEV Resistance Values

EEV (6-pin, 5 wire)

	White	Yellow	Orange	Blue	X	Red
White	-	92 Ω	92 Ω	92 Ω	-	46 Ω
Yellow	-	-	92 Ω	92 Ω	-	46 Ω
Orange	-	-	-	92 Ω	-	46 Ω
Blue	-	-	-	-	-	46 Ω
X	-	-	-	-	-	-
Red	-	-	-	-	-	-

EEV (6-pin, 6 wire)

	White	Yellow	Orange	Blue	Brown	Red
White	-	0L	92 Ω	0L	46 Ω	0L
Yellow	-	-	0L	92 Ω	0L	46 Ω
Orange	-	-	-	0L	46 Ω	0L
Blue	-	-	-	-	0L	46 Ω
Brown	-	-	-	-	-	0L
Red	-	-	-	-	-	-

Troubleshooting

Error Code (Indoor/Outdoor)

F2/LED1: 24 Flash

Overcurrent of the Compressor

Complete the "Check This First" Flow Chart before continuing.

Models:

ASYW09CRAWA
ASYW12CRAWA
ASYW18CRDWA
ASYW24CRDWA

ASH109CRAWA
ASH112CRAWA
ASH118CRAWA
ASH124CRAWA

See reverse side for wiring diagram and relevant color-coded test positions.

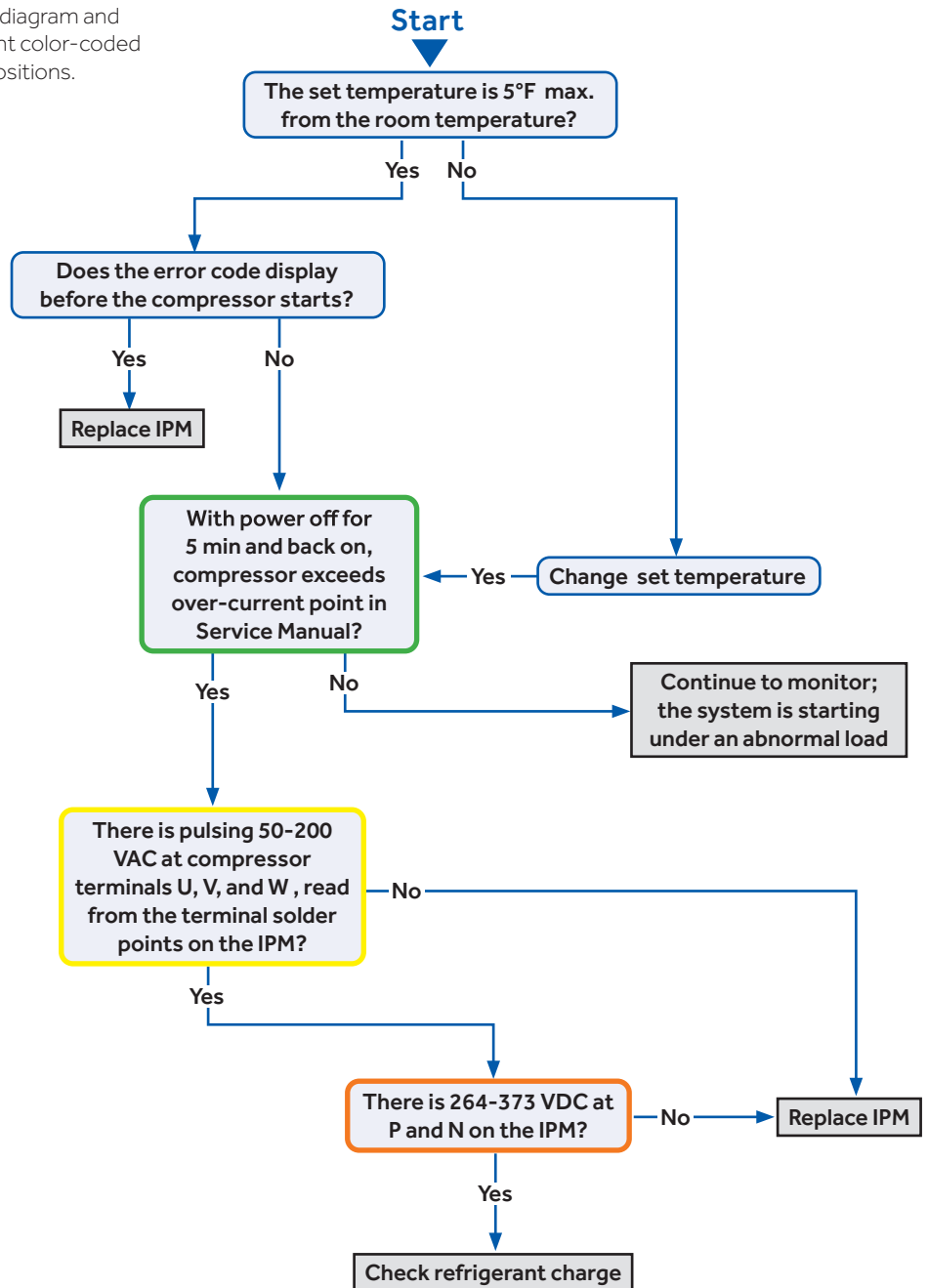

Troubleshooting

Error Code: F2/LED1: 24 Flash

Wiring Diagram Reference

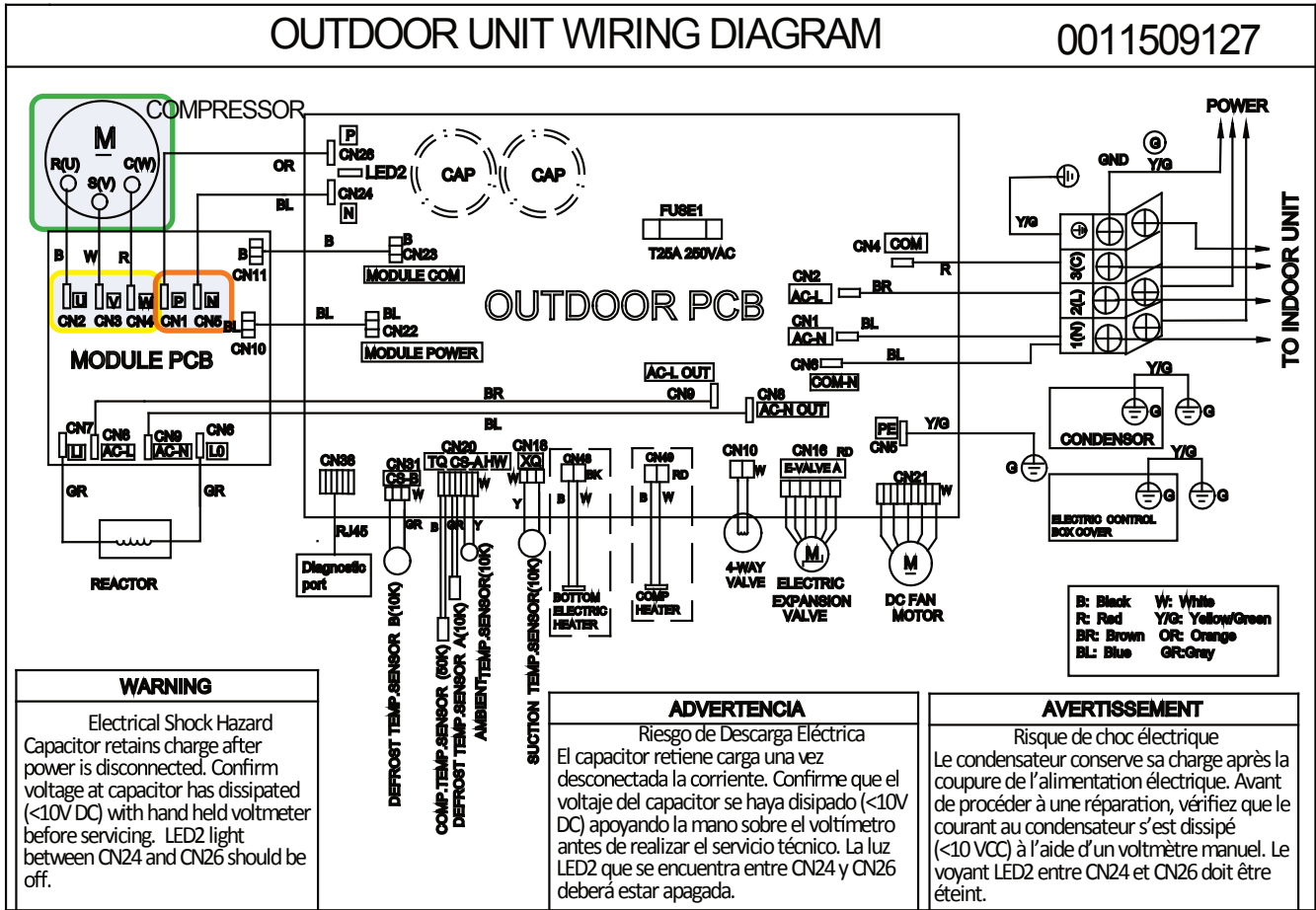

Troubleshooting

Error Code (Indoor/Outdoor)

F3/LED1: 4 Flash

Communication Fault Between IPM and Outdoor PCB

Complete the "Check This First" Flow Chart before continuing.

Models:

ASYW09CRAWA
ASYW12CRAWA
ASYW18CRDWA
ASYW24CRDWA

ASH109CRAWA
ASH112CRAWA
ASH118CRAWA
ASH124CRAWA

See reverse side for wiring diagram and relevant color-coded test positions.

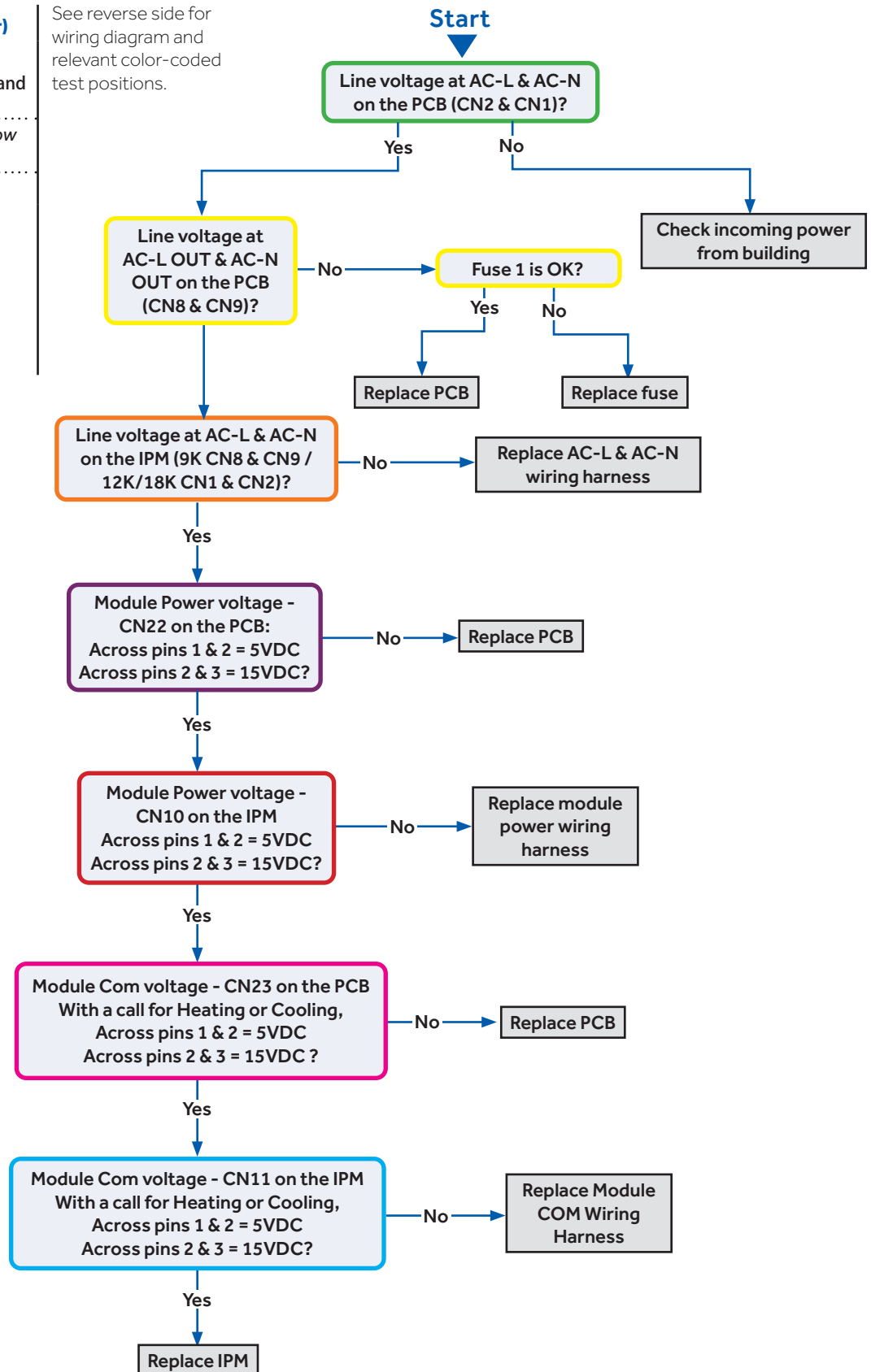

Troubleshooting

Error Code: F3/LED1: 4 Flash

Wiring Diagram Reference

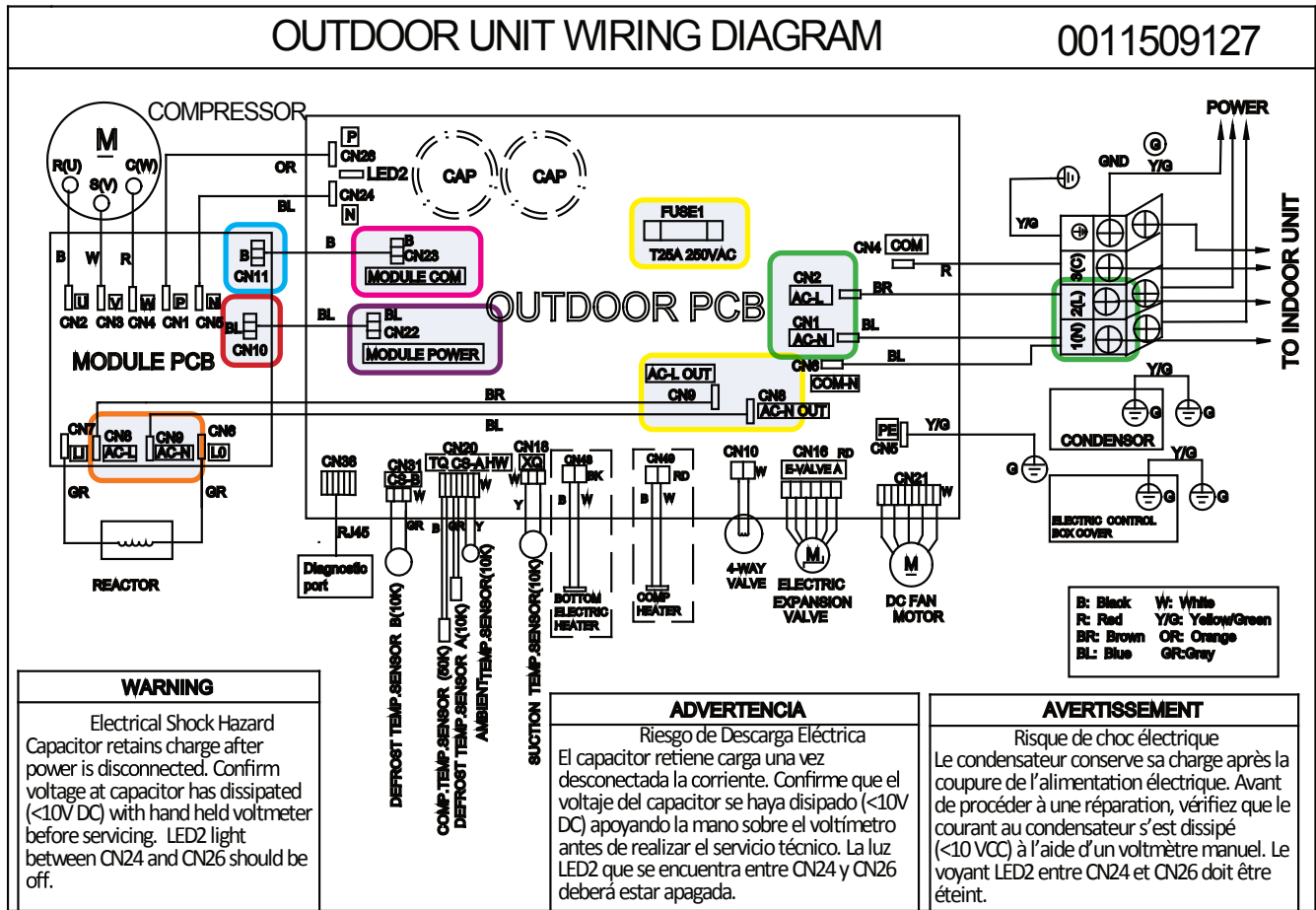

Error Code (Indoor/Outdoor)

F4/LED1: 8 Flash

Overheat Protection For Discharge Temperature

Complete the "Check This First" Flow Chart before continuing.

Models:

ASYW09CRAWA
ASYW12CRAWA
ASYW18CRDWA
ASYW24CRDWA

ASH109CRAWA
ASH112CRAWA
ASH118CRAWA
ASH124CRAWA

See reverse side for wiring diagram and relevant color-coded test positions.

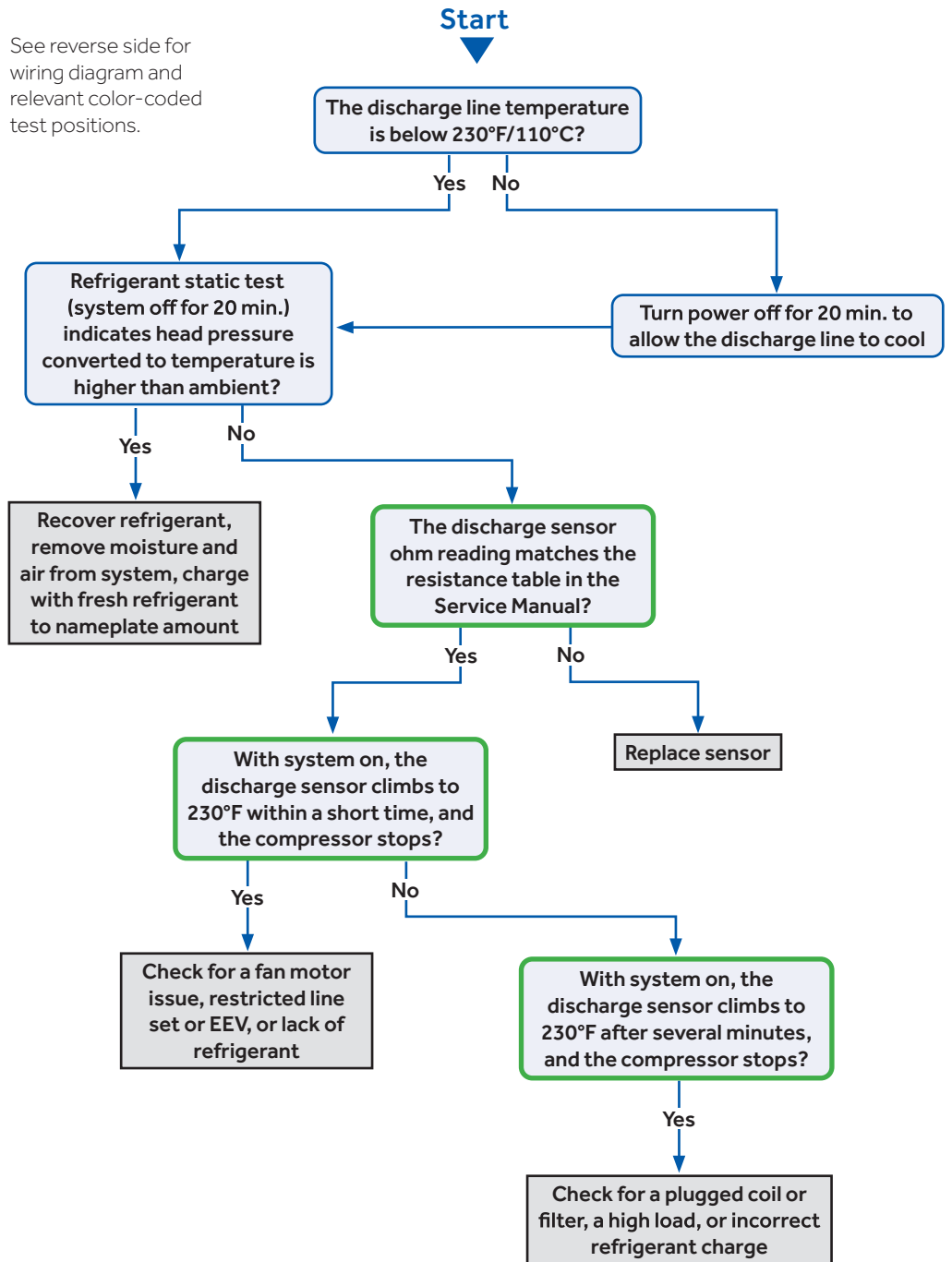

Troubleshooting

Error Code: F4/LED1: 8 Flash

Wiring Diagram Reference

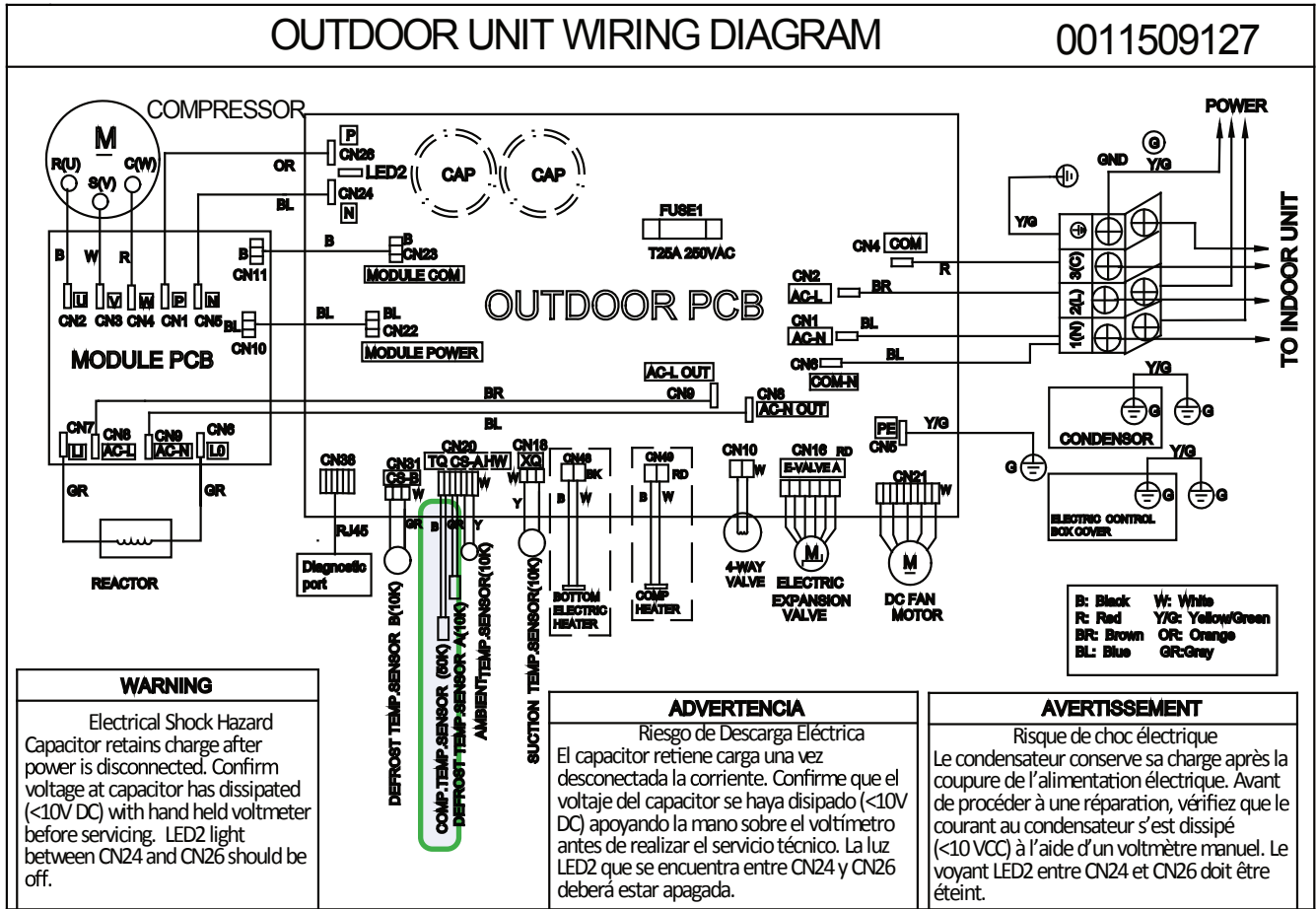

EEV Resistance Values

EEV (6-pin, 5 wire)

	White	Yellow	Orange	Blue	X	Red
White	-	92 Ω	92 Ω	92 Ω	-	46 Ω
Yellow	-	-	92 Ω	92 Ω	-	46 Ω
Orange	-	-	-	92 Ω	-	46 Ω
Blue	-	-	-	-	-	46 Ω
X	-	-	-	-	-	-
Red	-	-	-	-	-	-

EEV (6-pin, 6 wire)

	White	Yellow	Orange	Blue	Brown	Red
White	-	0L	92 Ω	0L	46 Ω	0L
Yellow	-	-	0L	92 Ω	0L	46 Ω
Orange	-	-	-	0L	46 Ω	0L
Blue	-	-	-	-	0L	46 Ω
Brown	-	-	-	-	-	0L
Red	-	-	-	-	-	-

Troubleshooting

Error Codes (Indoor/Outdoor)

F6/LED1: 12 Flash
Ambient Temperature Sensor Failure

F7/LED1: 11 Flash
Suction Temperature Sensor Failure

F21/LED1: 10 Flash
Defrost Temperature Sensor Failure

F25/LED1: 13 Flash
Discharge Temperature Sensor Failure

E1/LED1: No Flash
Room Temperature Sensor Failure

E2/LED1: No Flash
Indoor Coil Temperature Sensor Failure
Complete the "Check This First" Flow Chart before continuing.

Models:

ASYW09CRAWA
ASYW12CRAWA
ASYW18CRDWA
ASYW24CRDWA

ASH109CRAWA
ASH112CRAWA
ASH118CRAWA
ASH124CRAWA

See reverse side for wiring diagram, relevant color-coded test positions, and sensor resistance values.

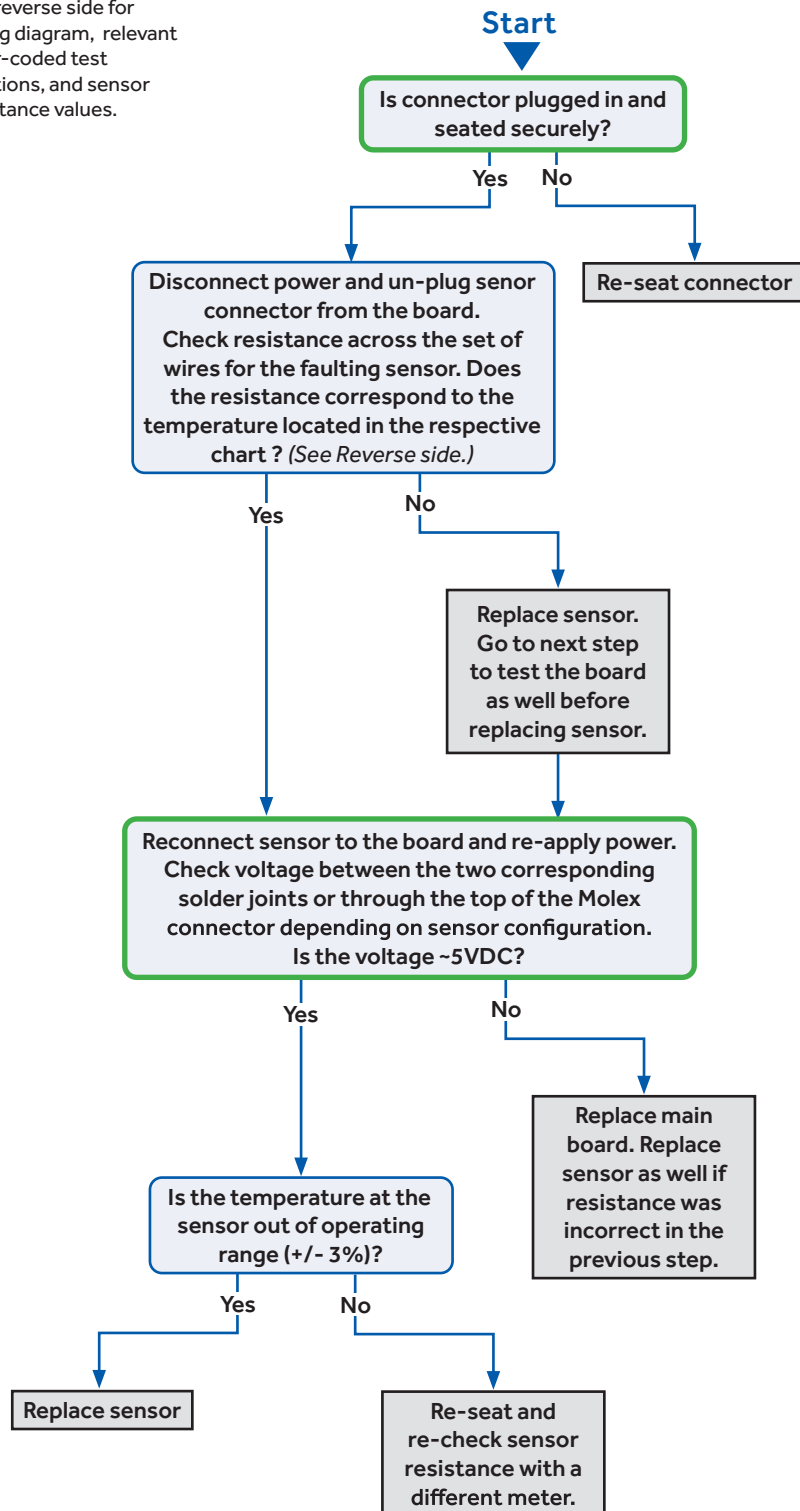

Troubleshooting

Error Code: F6/LED1: 12 Flash, F7/LED1: 11 Flash, F21/LED1: 10 Flash, F25/LED1: 13 Flash, E1/LED1: No Flash, E2/LED1: No Flash

Wiring Diagram Reference

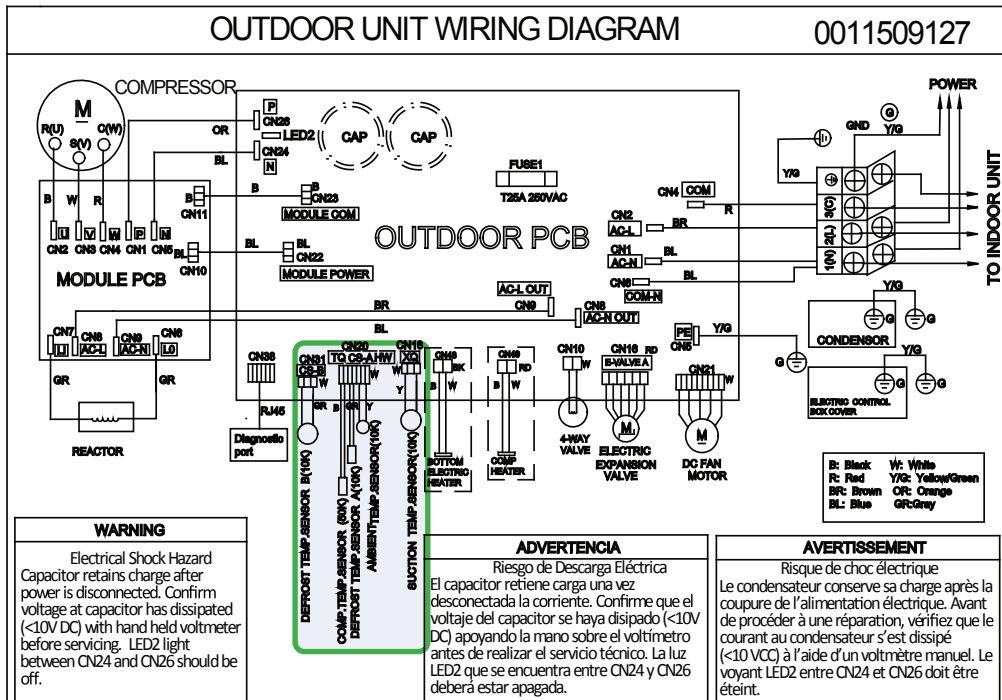

Sensor Resistance Table

°F	°C	Normal (KΩ)		
		10K SENSORS	23K SENSORS	50K SENSORS
-0.4	-18	75.44	235.90	5494.21
5.0	-15	64.30	196.61	4558.19
10.4	-12	54.99	164.40	3795.39
14.0	-10	49.62	146.15	3365.73
21.2	-6	40.58	115.95	2658.81
24.8	-4	36.77	103.46	2368.32
32.0	0	30.30	82.69	1887.00
35.6	2	27.55	74.07	1687.81
41.0	5	23.95	62.94	1431.28
44.6	7	21.84	56.57	1284.36
50.0	10	19.06	48.31	1094.32
55.4	13	16.68	41.40	934.94
59.0	15	15.28	37.41	843.05
64.4	18	13.42	32.22	723.41
69.8	21	11.81	27.83	622.32
75.2	24	10.42	24.11	536.65
77.0	25	10.00	23.00	511.08
80.6	27	9.21	20.95	464.05
86.0	30	8.16	18.25	402.24
89.6	32	7.54	16.67	366.13
95.0	35	6.70	14.59	318.52
100.4	38	5.97	12.79	277.70

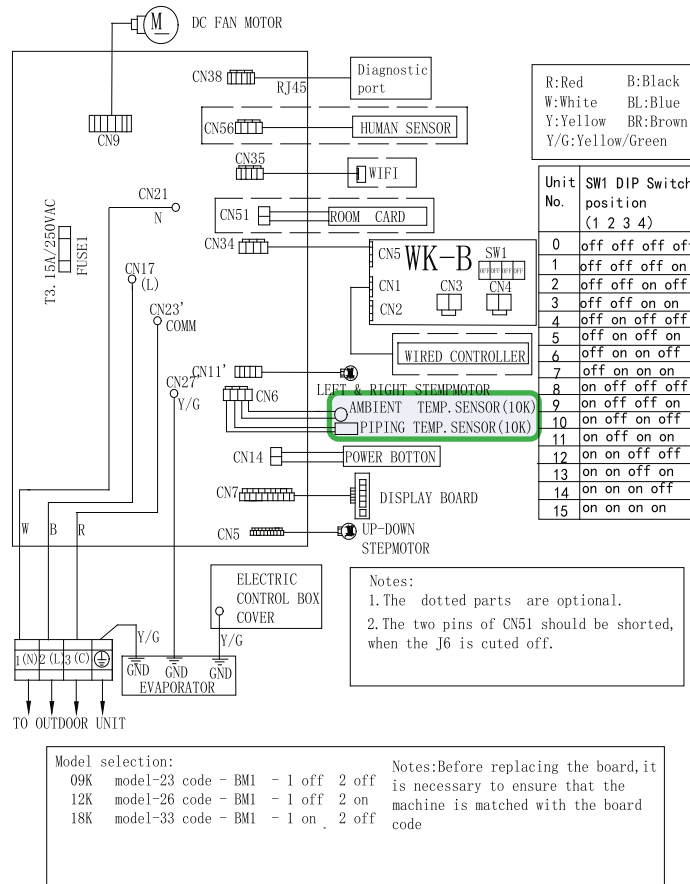

Troubleshooting

Error Code (Indoor/Outdoor)

F8/LED1: 9 Flash

Outdoor DC Fan Motor Fault

Complete the "Check This First" Flow Chart before continuing.

Models:

ASYW09CRAWA
ASYW12CRAWA
ASYW18CRDWA
ASYW24CRDWA

ASH109CRAWA
ASH112CRAWA
ASH118CRAWA
ASH124CRAWA

See reverse side for wiring diagram and relevant color-coded test positions.

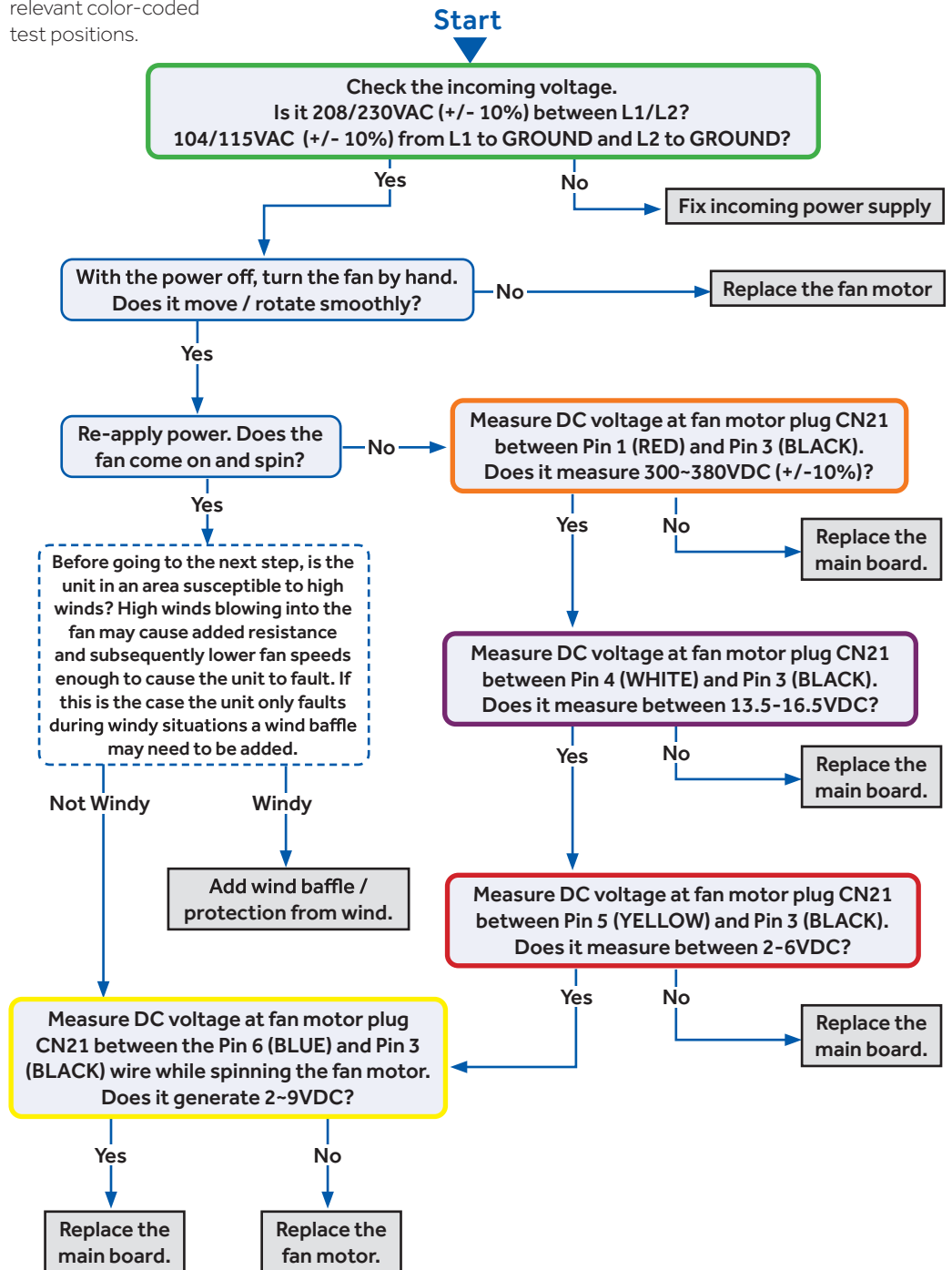

Troubleshooting

Error Code: F8/LED1: 9 Flash

Wiring Diagram Reference

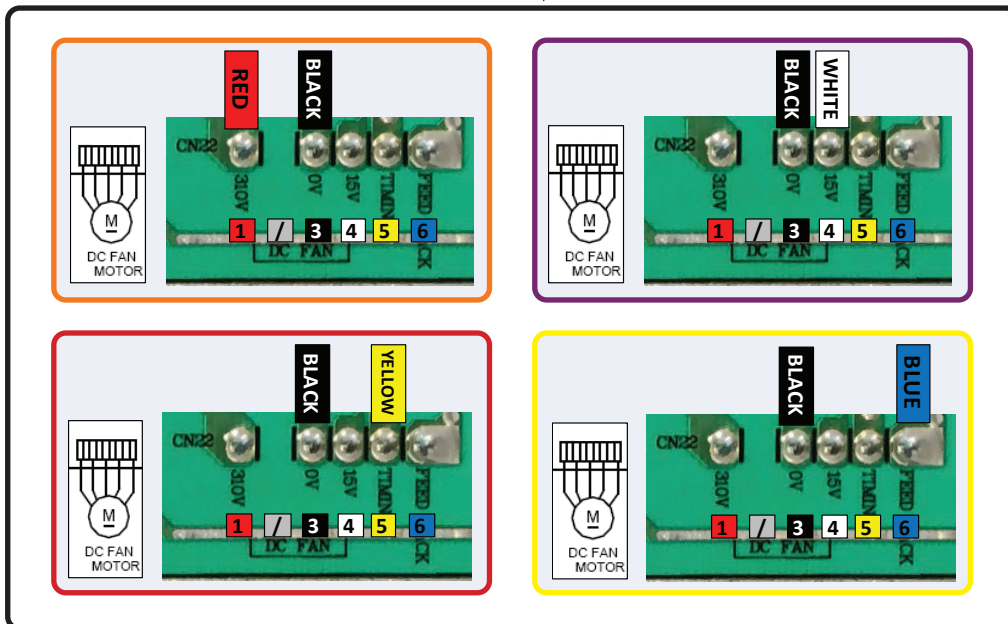
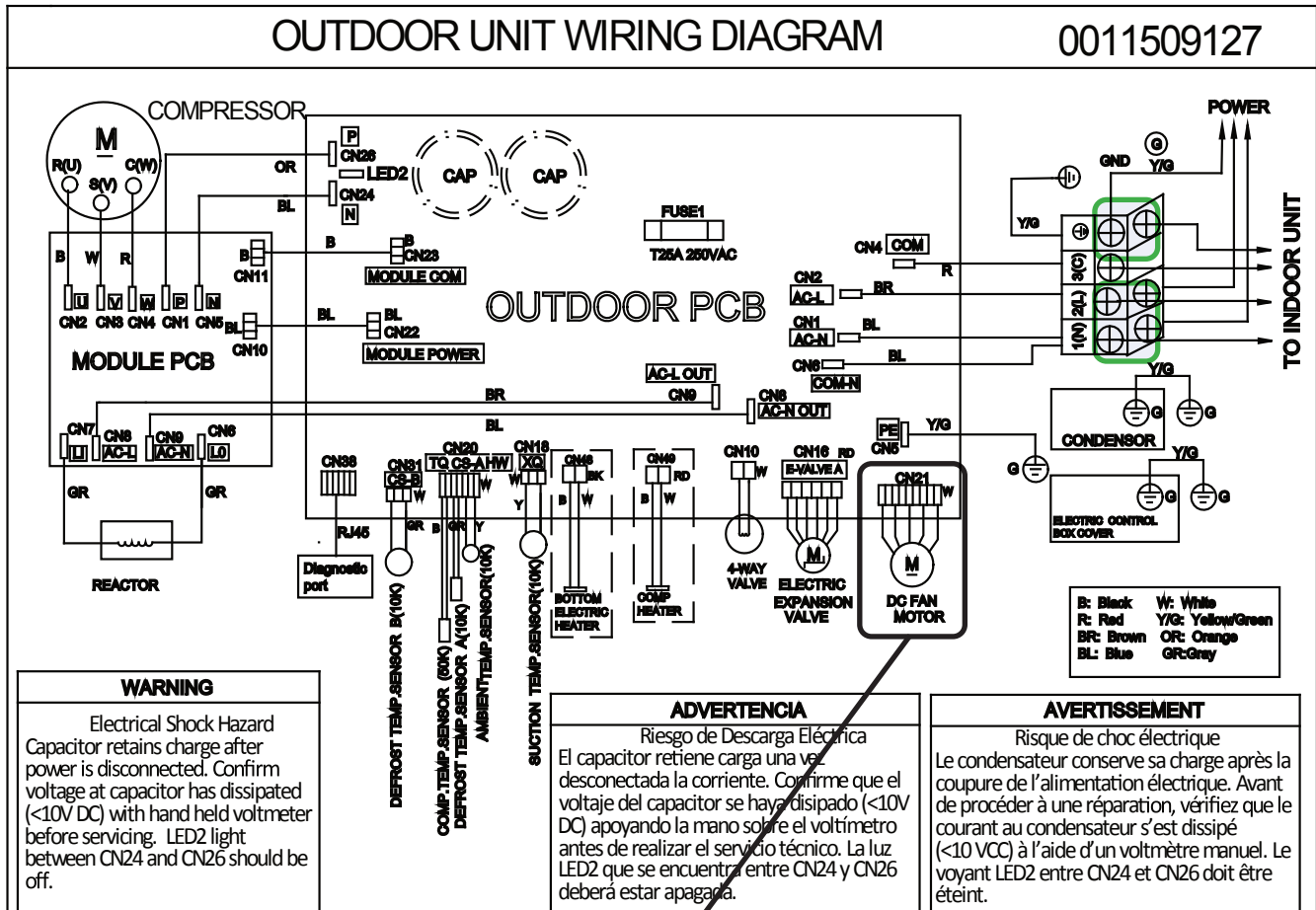

Error Code (Indoor/Outdoor)

F11/LED1: 18 Flash

Loss of Compressor Synchronization

Complete the "Check This First" Flow Chart before continuing.

Models:

ASYW09CRAWA
ASYW12CRAWA
ASYW18CRDWA
ASYW24CRDWA

ASH109CRAWA
ASH112CRAWA
ASH118CRAWA
ASH124CRAWA

See reverse side for wiring diagram and relevant color-coded test positions.

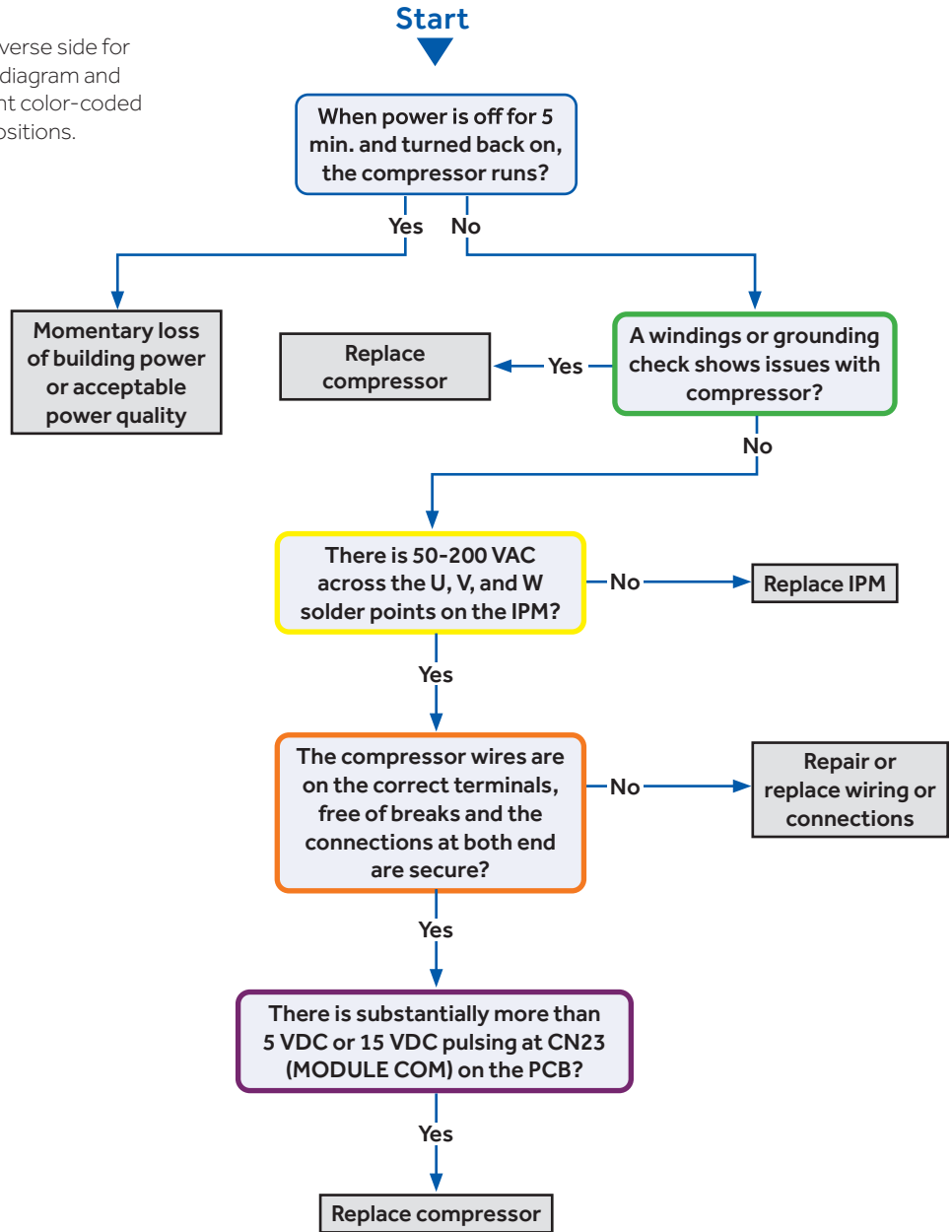

Troubleshooting

Error Code: F11/LED1: 18 Flash

Wiring Diagram Reference

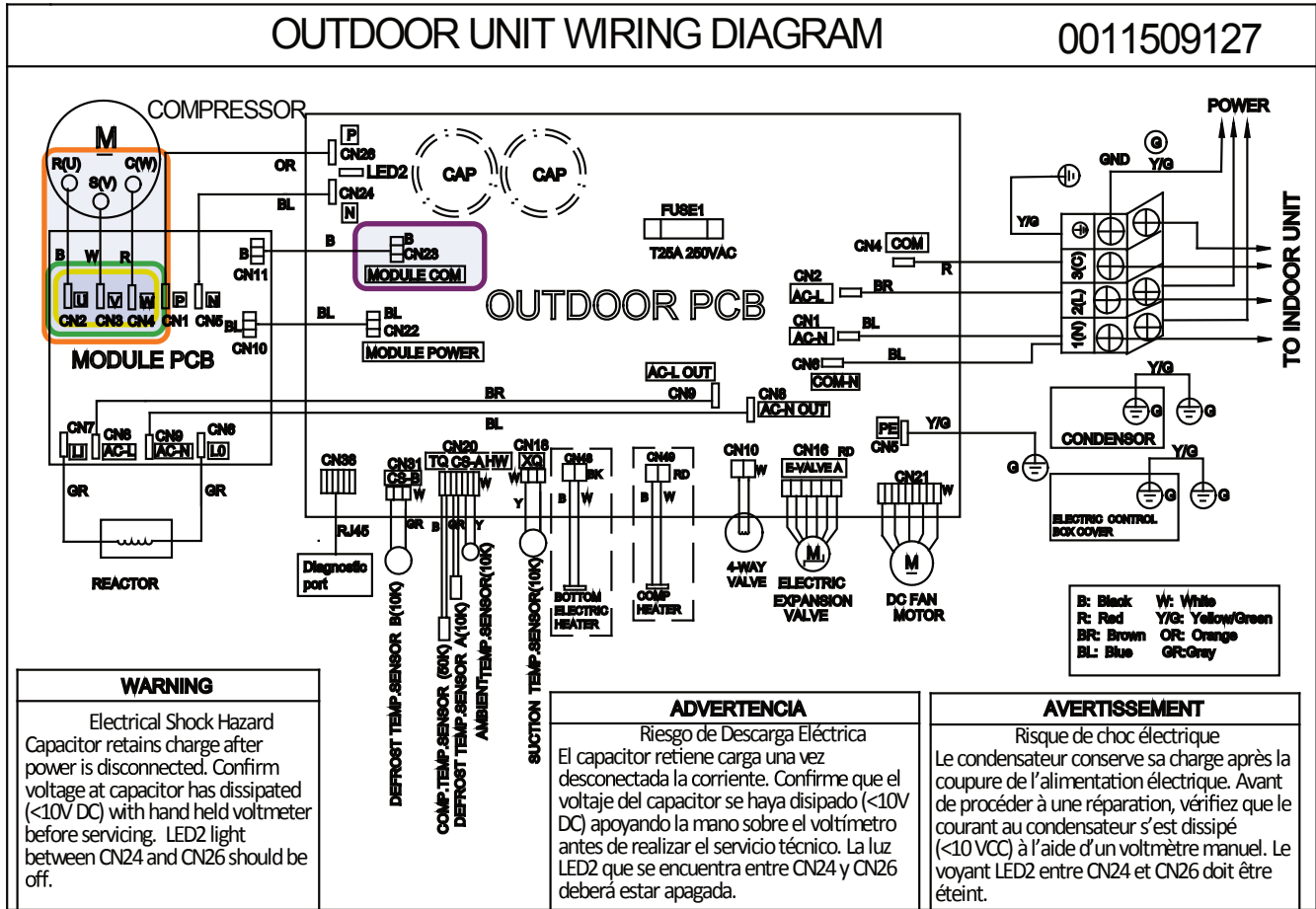

Troubleshooting

Error Code (Indoor/Outdoor)

F12/LED1: 1 Flash

EEPROM Error

Complete the "Check This First" Flow Chart before continuing.

Models:

ASYW09CRAWA
ASYW12CRAWA
ASYW18CRDWA
ASYW24CRDWA

ASH109CRAWA
ASH112CRAWA
ASH118CRAWA
ASH124CRAWA

See reverse side for wiring diagram and relevant color-coded test positions.

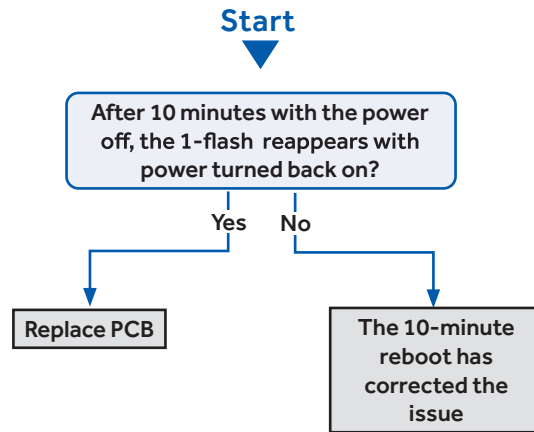

Wiring Diagram Reference

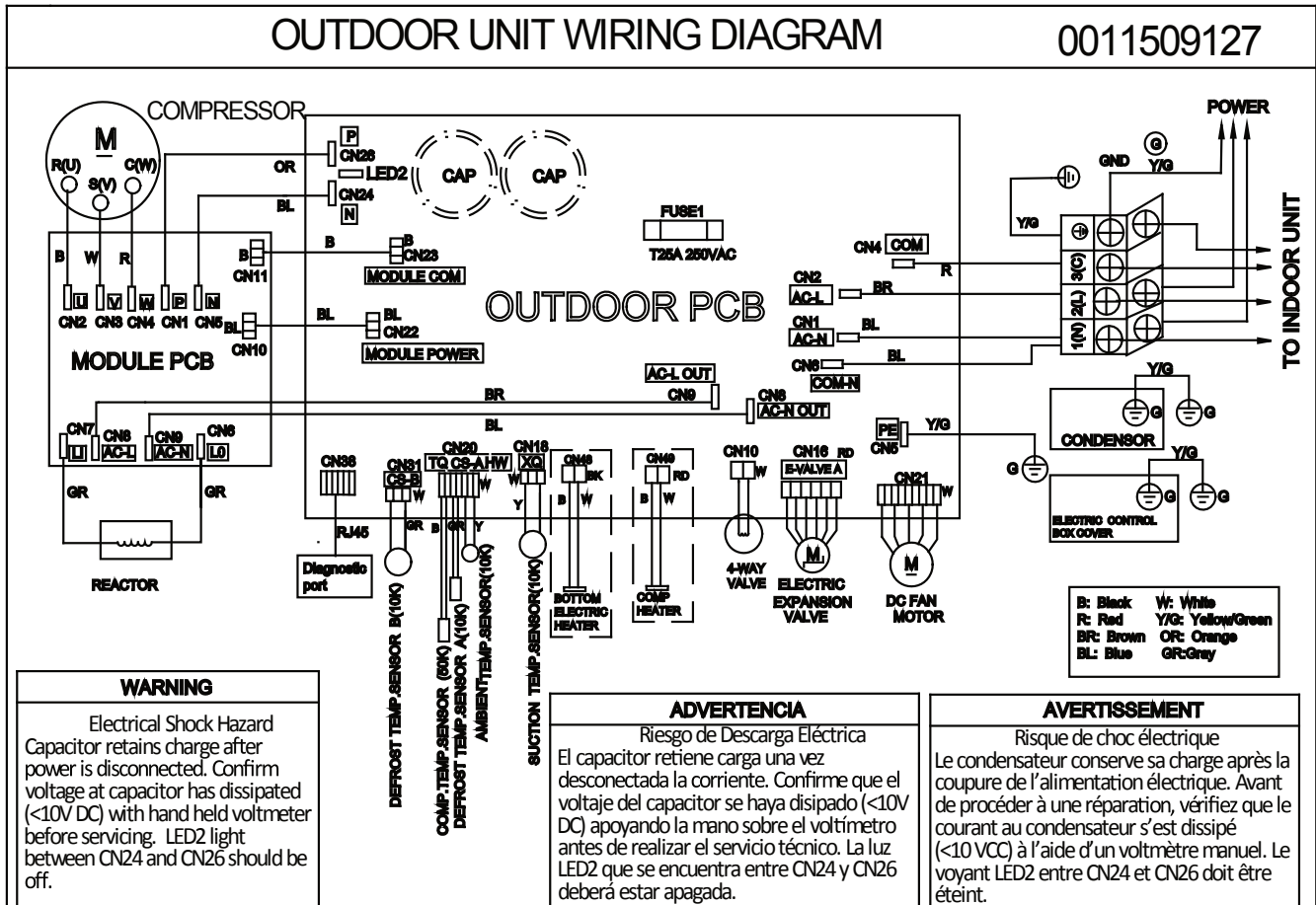

Error Code (Indoor/Outdoor)

E5/LED1: 22 Flash

Coil Frost Protection

Complete the "Check This First" Flow Chart before continuing.

Models:

ASYW09CRAWA
ASYW12CRAWA
ASYW18CRDWA
ASYW24CRDWA

ASH109CRAWA
ASH112CRAWA
ASH118CRAWA
ASH124CRAWA

See reverse side for wiring diagram and relevant color-coded test positions.

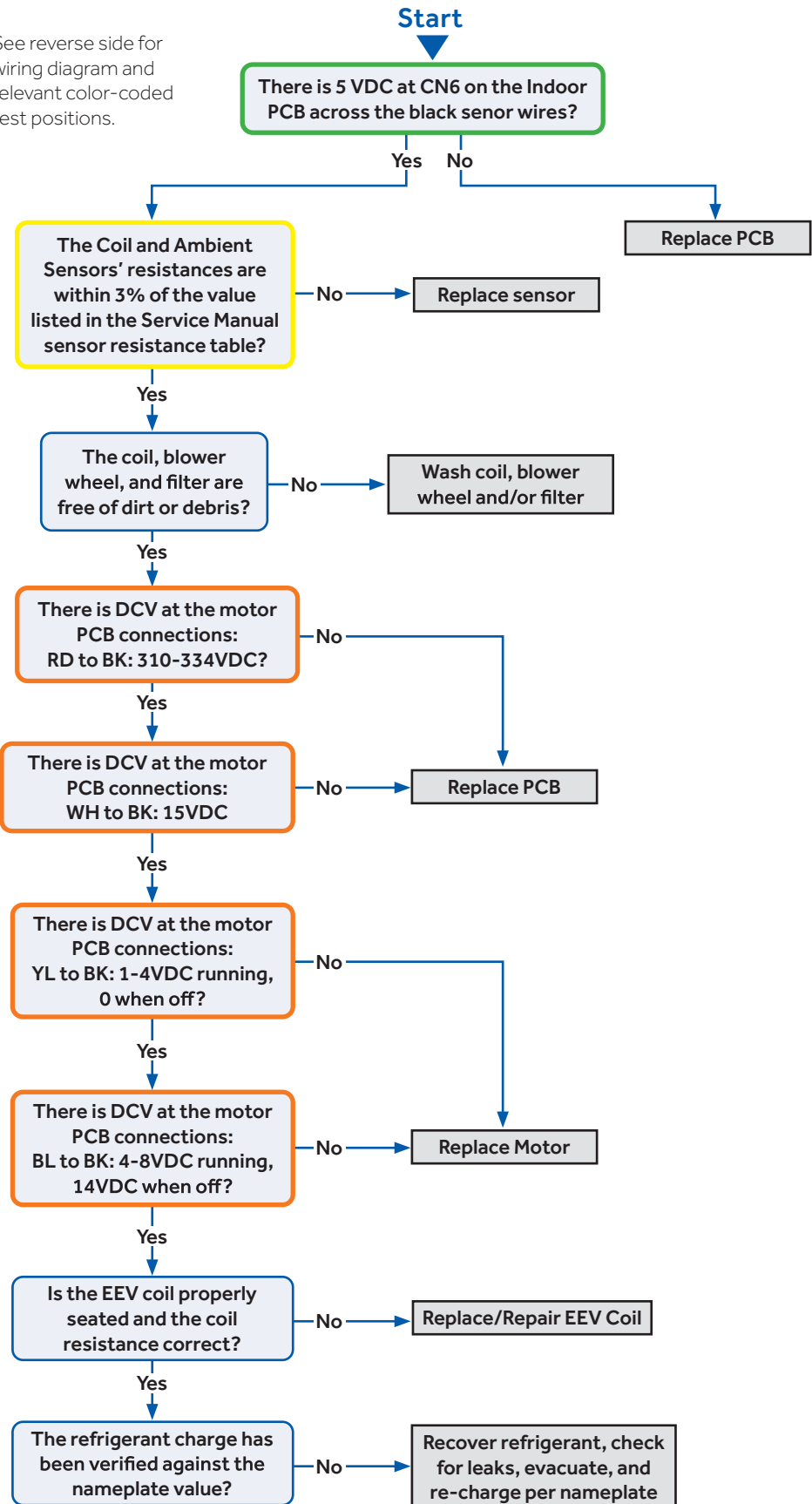

Troubleshooting

Error Code: E5/LED1: 22 Flash

Wiring Diagram Reference

Sensor Resistance Table

°F	°C	Normal (KΩ)		
		10K SENSORS	23K SENSORS	50K SENSORS
-0.4	-18	75.44	235.90	5494.21
5.0	-15	64.30	196.61	4558.19
10.4	-12	54.99	164.40	3795.39
14.0	-10	49.62	146.15	3365.73
21.2	-6	40.58	115.95	2658.81
24.8	-4	36.77	103.46	2368.32
32.0	0	30.30	82.69	1887.00
35.6	2	27.55	74.07	1687.81
41.0	5	23.95	62.94	1431.28
44.6	7	21.84	56.57	1284.36
50.0	10	19.06	48.31	1094.32
55.4	13	16.68	41.40	934.94
59.0	15	15.28	37.41	843.05
64.4	18	13.42	32.22	723.41
69.8	21	11.81	27.83	622.32
75.2	24	10.42	24.11	536.65
77.0	25	10.00	23.00	511.08
80.6	27	9.21	20.95	464.05
86.0	30	8.16	18.25	402.24
89.6	32	7.54	16.67	366.13
95.0	35	6.70	14.59	318.52
100.4	38	5.97	12.79	277.70

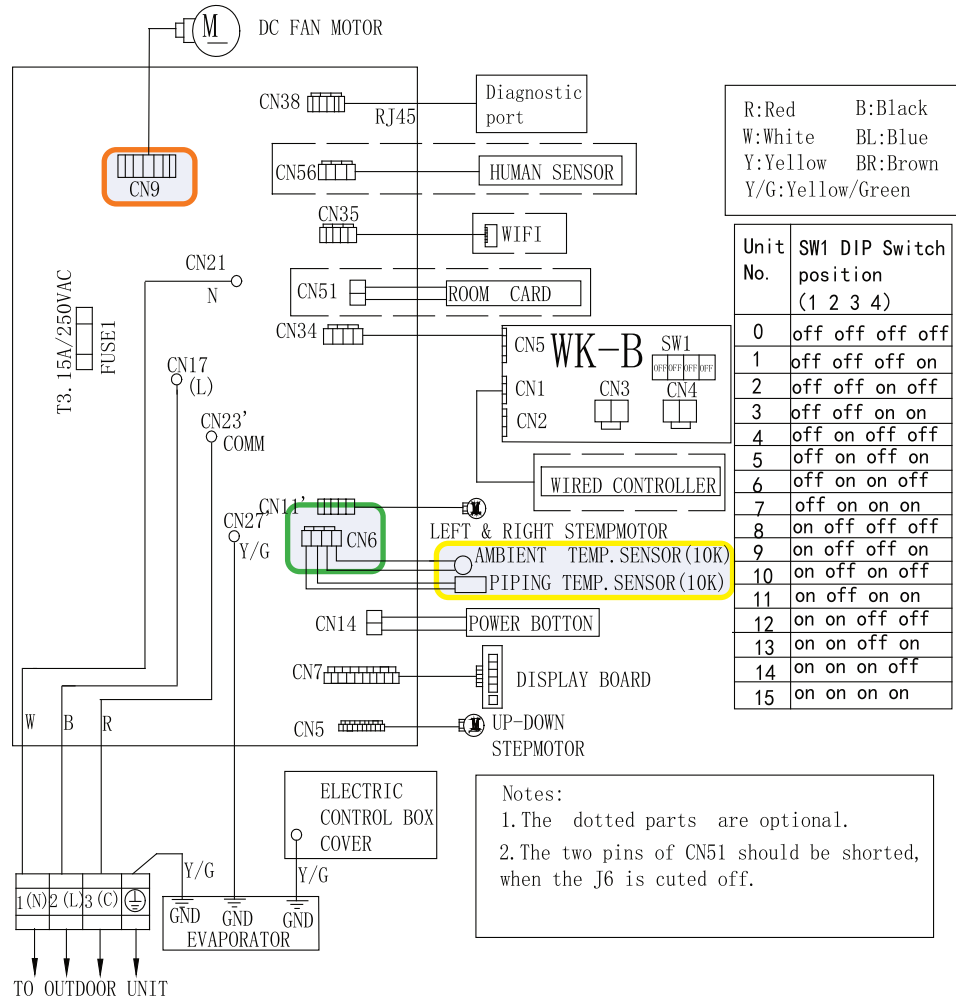

Model selection:

09K	model-23	code - BM1	- 1 off	2 off	Notes: Before replacing the board, it is necessary to ensure that the machine is matched with the board code
12K	model-26	code - BM1	- 1 off	2 on	
18K	model-33	code - BM1	- 1 on	2 off	

EEV Resistance Values

EEV (6-pin, 5 wire)

	White	Yellow	Orange	Blue	X	Red
White	-	92 Ω	92 Ω	92 Ω	-	46 Ω
Yellow	-	-	92 Ω	92 Ω	-	46 Ω
Orange	-	-	-	92 Ω	-	46 Ω
Blue	-	-	-	-	-	46 Ω
X	-	-	-	-	-	-
Red	-	-	-	-	-	-

EEV (6-pin, 6 wire)

	White	Yellow	Orange	Blue	Brown	Red
White	-	OL	92 Ω	OL	46 Ω	OL
Yellow	-	-	OL	92 Ω	OL	46 Ω
Orange	-	-	-	OL	46 Ω	OL
Blue	-	-	-	-	OL	46 Ω
Brown	-	-	-	-	-	OL
Red	-	-	-	-	-	-

Error Code (Indoor/Outdoor)

E7/LED1: 15 Flash

ID and OD Loss of Communication

Complete the "Check This First" Flow Chart for both ID and OD units before continuing.

Models:

ASYW09CRAWA
ASYW12CRAWA
ASYW18CRDWA
ASYW24CRDWA

ASH109CRAWA
ASH112CRAWA
ASH118CRAWA
ASH124CRAWA

See reverse side for wiring diagram and relevant color-coded test positions.

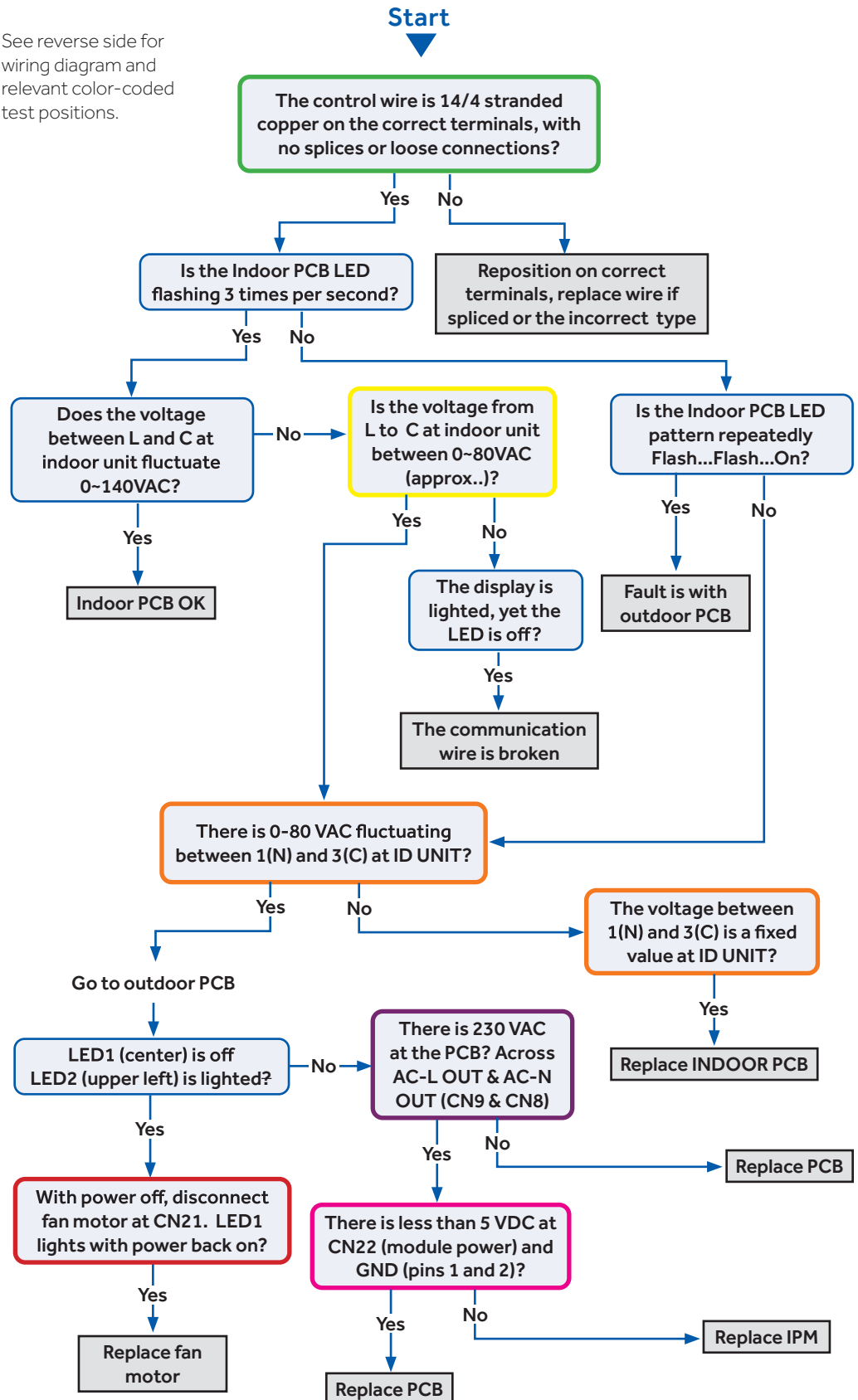

Troubleshooting

Error Code: E7/LED1: 15 Flash

Wiring Diagram Reference

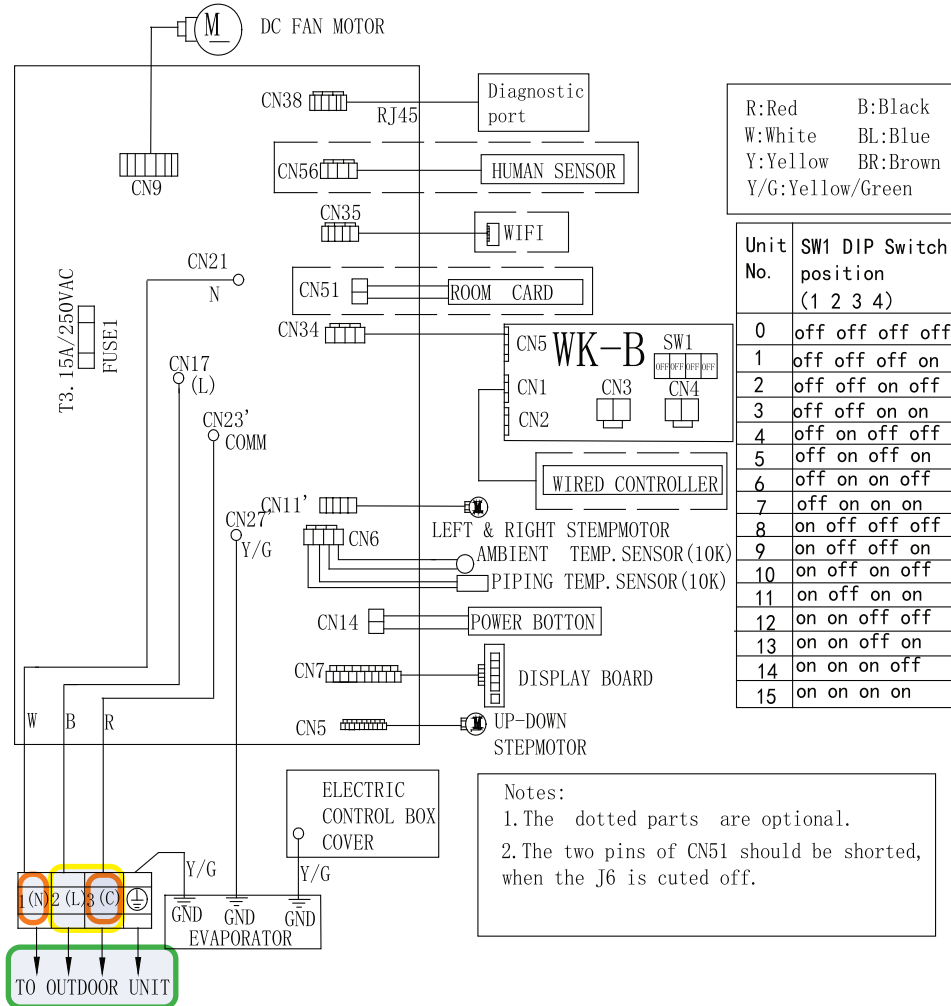

Model selection:

09K	model-23	code - BM1	- 1 off	2 off
12K	model-26	code - BM1	- 1 off	2 on
18K	model-33	code - BM1	- 1 on	2 off

Notes: Before replacing the board, it is necessary to ensure that the machine is matched with the board code

Troubleshooting

Error Code: E7/LED1: 15 Flash

Wiring Diagram Reference

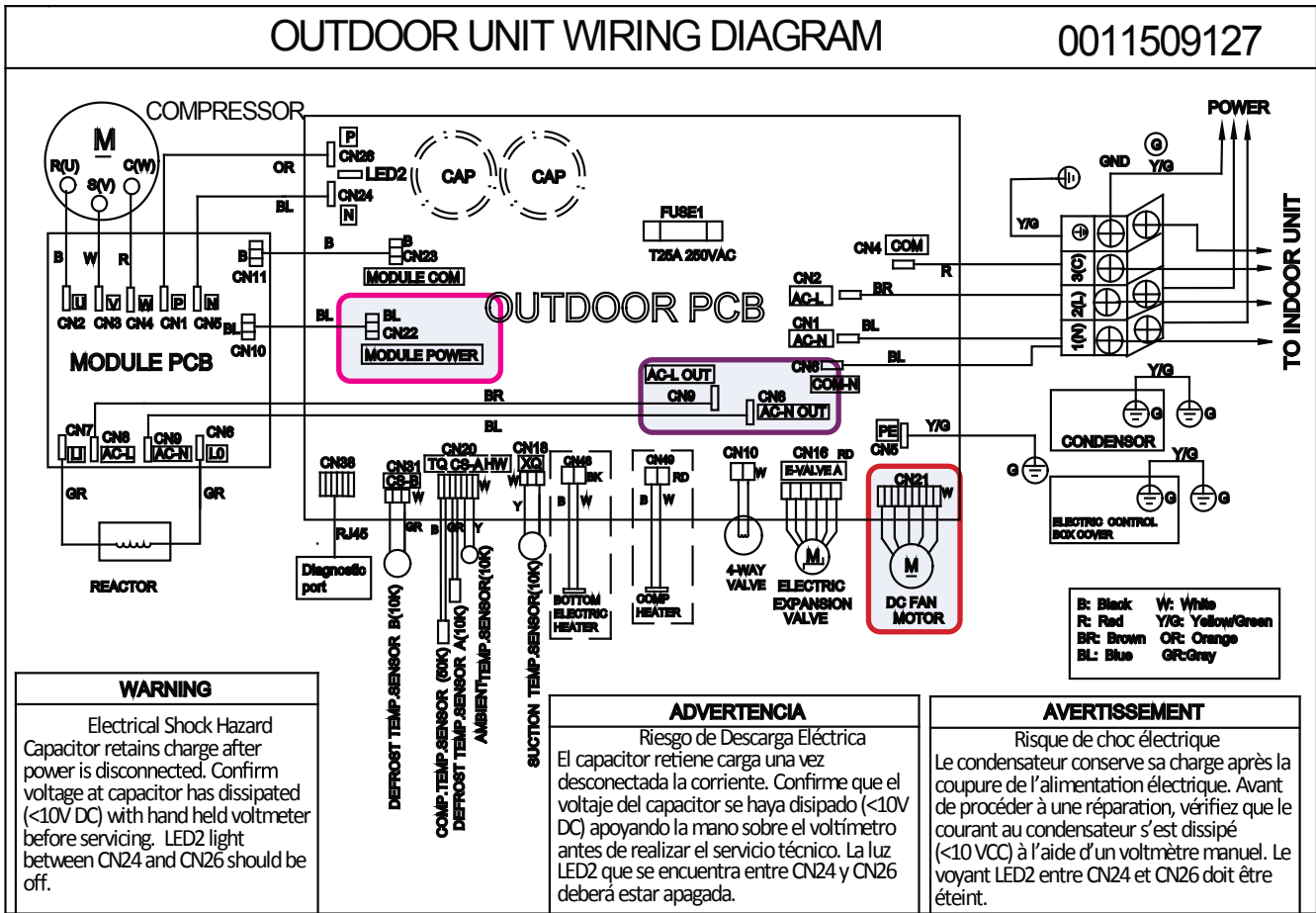

Troubleshooting

Error Code (Indoor)

E14

Indoor Fan Motor Failure

Complete the "Check This First" Flow Chart before continuing.

Models:

ASYW09CRAWA
ASYW12CRAWA
ASYW18CRDWA
ASYW24CRDWA

See reverse side for wiring diagram and relevant color-coded test positions.

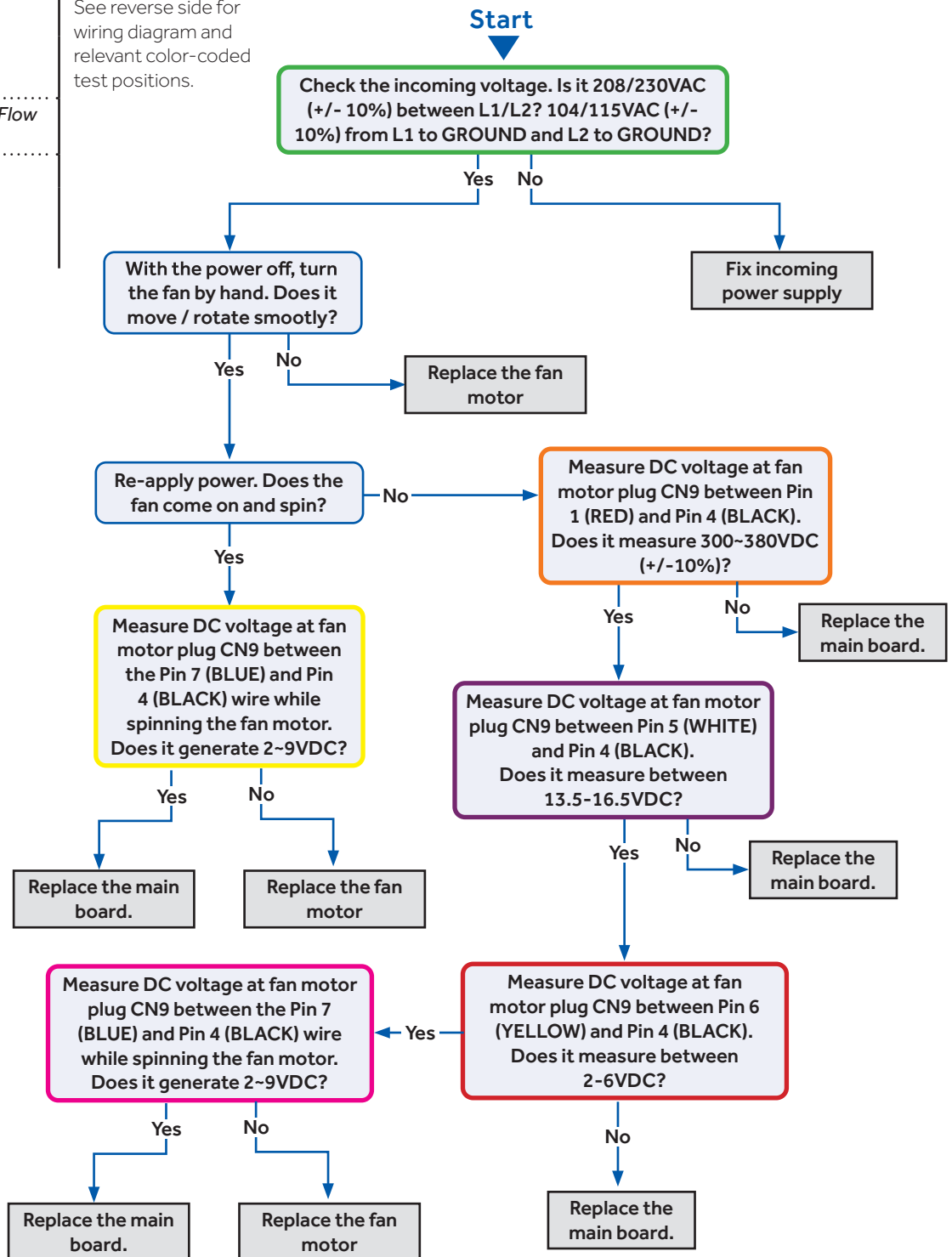

Troubleshooting

Error Code: E14

Wiring Diagram Reference

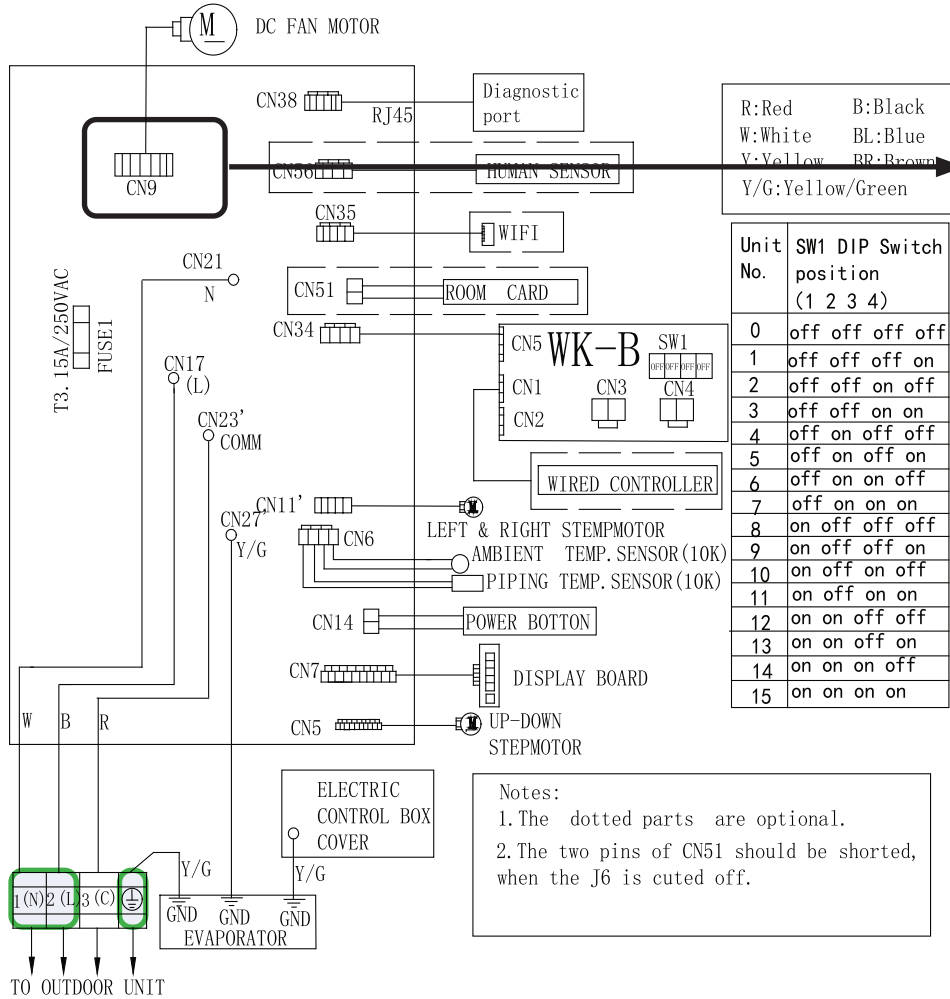

Model selection:

09K	model-23	code - BM1	- 1 off	2 off
12K	model-26	code - BM1	- 1 off	2 on
18K	model-33	code - BM1	- 1 on	2 off

Notes: Before replacing the board, it is necessary to ensure that the machine is matched with the board code

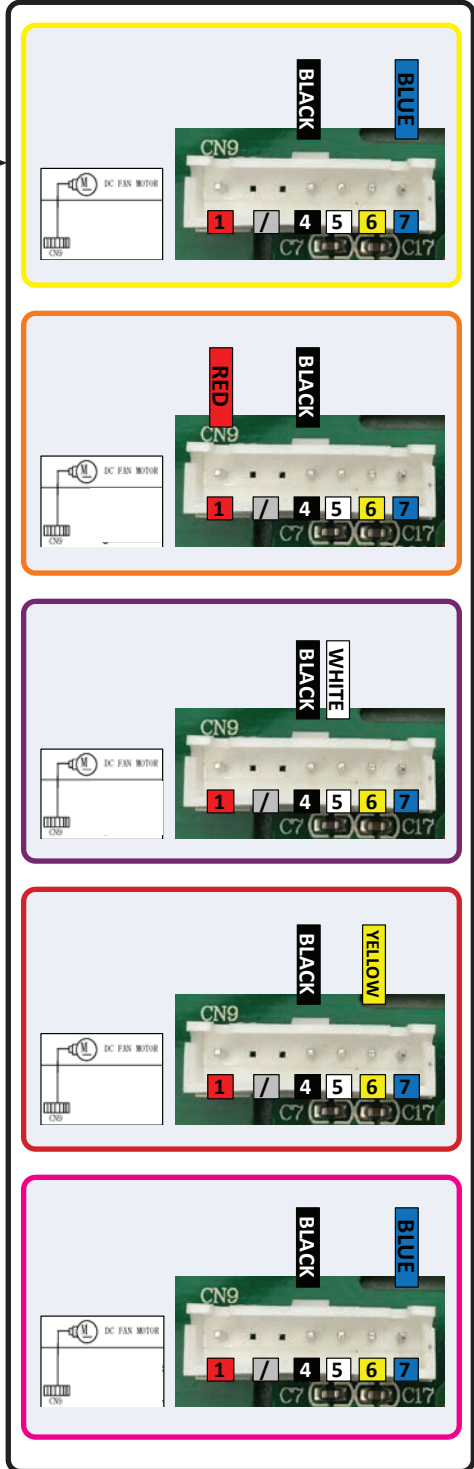

Checking System Components

NOTE: Component resistance readings shown in this section are for reference only. Actual resistance values may differ based on model being tested.

Checking Outdoor Unit Components

Testing of the following components requires the use of an ohmmeter and temperature probe.

NOTE: Use needle probes only, and probe the back or side contacts of the plug to obtain the reading. Do not try to probe the connector end of the plug, as this may damage the contacts of the plug.

Checking the Outdoor Unit Sensors

NOTE: Use respective temperature / sensor chart for sensor type being tested.

Compressor discharge sensor
Suction sensor
Tube sensor (defrost temperature)
Ambient sensor

Step 1

Disconnect the sensor plug from the control board for this test. Failure to do so may provide inaccurate readings.

Step 2

k-type temperature probe, determine the temperature of the sensor.

Step 3

Using an ohmmeter, check the resistance value of the sensor.

Step 4

Referring to the temperature / resistance table specific table, verify the resistance value corresponds to the temperature checked in step 2. Replace the sensor if the reading is open, shorted, or outside the specifications of the table.

Step 5

Re-seat the plug on the connector at the conclusion of the test.

Checking the Reversing Valve Coil

Step 1

Disconnect the reversing valve plug from the control board connector for this test. Failure to do so may provide inaccurate readings.

Step 2

Using an ohmmeter, test the coil to make sure it is not open, shorted, or grounded. The 09k and 12k models have a four way valve (4WV) that operates differently from the standard 230 VAC units normally found in mini-split systems. Rather than the voltage applied to the valve coil remaining as long as the call for heat is active, the Tempo 115 VAC models apply momentary

power in the 103 to 126 VAC range. This power remains long enough to switch the valve piston from cooling to heating mode. Since the refrigerant pressure flowing from the valve body capillary tube holds the piston in place, allowing hot gas to redirect into the indoor coil, the VAC signal is no longer needed and is removed by the PCB. 18k and 24k models will read 230 VAC across the coil as long as the unit is in the heating (energized) mode.

Step 3

Re-seat the plug on the connector at the conclusion of the test.

Checking the DC Fan Motor

Step 1

Disconnect the DC Fan Motor plug from the control board connector for this test. Failure to do so may provide inaccurate readings.

Step 2

Refer to the chart shown below for plug pin combinations and resistance values.

Note: Test is polarity sensitive, adhere to probe placement as shown in chart.

		Red Test Lead					
		Red	---	Black	White	Yellow	Blue
Black Test Lead	Red		---	3.10Meg	3.05Meg	3.28 Meg	Chargesto infinity
	---			---	---	---	---
	Black				43.85K	145.1K	Charges to infinity
	White					189.0K	Charges to infinity
	Yellow						Charges to infinity
	Blue						

Step 3

Re-seat the plug on the connector at the conclusion of the test.

Checking the EEV Stepper Motor

Step 1

Disconnect the EEV Stepper Motor plug from the control board connector for this test. Failure to do so may provide inaccurate readings.

Step 2

Refer to the chart shown below for plug pin combinations and resistance values.

	White	Yellow	Orange	Blue	Red	Grey
White		---	92.6Ohm	---	47.0	Ohm ---
Yellow			---	93.1 Ohm	47.0	Ohm
Orange					46.5	Ohm ---
Blue					46.8	Ohm
Red						---
Grey						

Step 3

Re-seat the plug on the connector at the conclusion of the test.

Checking the PFC Reactor

Step 1

Disconnect wires from terminals LI and LO of the power module board.

Step 2

Using an Ohmmeter, check the resistance value of the PFC Reactor. The resistance value of the coil is less than 1 Ohm. If the resistance value differs from this value, verify the

wiring and connections to the PFC Reactor as well as the PFC Reactor itself. Repair or replace as necessary.

Step 3

Reconnect the wiring to the module board at the conclusion of the test.

Step 1

Disconnect the Socket Protect plug from the control board connector for this test. Failure to do so may provide inaccurate readings.

Step 2

Using an ohmmeter, check the resistance value of the Socket Protect component. The resistance reading should be 0 Ohms. If it is not, replace the component.

Step 3

Re-seat the plug on the connector at the conclusion of the test.

Checking the Compressor Windings

Step 1

Disconnect wiring from terminals U (black wire), V (white wire), and W (red wire) of the power module board.

Step 2

Using an ohmmeter, check the resistance value of the compressor windings. Measure between wires U (black wire) and V (white wire), U (black wire) and W (red wire), and V (white wire), and W (red wire).

The resistance value of the windings should be balanced (equal). If the resistance values are not equal, verify the wiring and connections to the compressor as well as the compressor itself. Repair or replace as needed.

Step 3

Reconnect the wiring to the module board at the conclusion of the test.

NOTE: Component resistance readings shown in this section are for reference only. Actual resistance values may differ based on model being tested.

Checking Indoor Unit Components

Testing of the following components requires the use of an ohmmeter and temperature probe (Temperature probe is used during sensor testing only).

NOTE: When using the test probes, probe the back or side contacts of the plug to obtain the reading. Do not try to probe the connector end of the plug as this may damage the contacts of the plug.

Checking the Indoor Unit Sensors

NOTE: Use respective temperature / sensor chart for sensor

type being tested.

Coil sensor

Ambient sensor

Step 1

Disconnect the sensor plug from the control board for this test. Failure to do so may provide inaccurate readings.

Step 2

Using a temperature probe, determine the temperature of the sensor being tested.

Step 3

Using an ohmmeter, check the resistance value of the sensor.

Step 4

Referring to the temperature / resistance table for the sensor being checked, verify the resistance value corresponds to the temperature checked in Step 2.

Replace the sensor if the reading is open, shorted, or outside the specifications of the temperature / resistance table.

Step 5

Re-seat the plug on the connector at the conclusion of the test.

Checking the Up/Down Stepper Motors

Step 1

Disconnect the Up/Down Stepper Motor plug from the control board connector for this test. Failure to do so may provide inaccurate readings.

Step 2

Refer to the chart shown below for plug pin combinations and resistance values.

	White	Yellow	Orange	Blue	Red	Grey
White		---	92.6 Ohm	---	47.0 Ohm	---
Yellow			---	93.1 Ohm	---	47.0 Ohm
Orange					46.5 Ohm	---
Blue						46.8 Ohm
Red						---
Grey						

Step 3

Re-seat the plug on the connector at the conclusion of the test.

Checking the Left/Right Stepper Motors

Step 1

Disconnect the Left Stepper Motor plug from the control board connector for this test. Failure to do so may provide inaccurate readings.

Step 2

Refer to the chart shown below for plug pin combinations and resistance values.

	Red	Orange	Yellow	Pink	Blue	Grey
Red		193.0 Ohm	189.5 Ohm	185.4 Ohm	191.5 Ohm	---
Orange			381.6 Ohm	377.4 Ohm	383.3 Ohm	47.0 Ohm
Yellow				373.9 Ohm	379.9 Ohm	---
Pink					375.8 Ohm	46.8 Ohm
Blue						---
Grey						

Step 3

Re-seat the plug on the connector at the conclusion of the test.

Checking the Indoor DC Fan Motor

Step 1

Disconnect the DC Fan Motor plug from the control board connector for this test. Failure to do so may provide inaccurate readings.

Step 2

Refer to the chart shown below for plug pin combinations and resistance values.

Note: Test is polarity sensitive, adhere to probe placement as shown in chart.

		Red Test Lead						
Black Test Lead		Pink	X	X	Black	White	Blue	Yellow
	Pink		X	X	15.27Meg	15.46 Meg	Infinity	15.85 Meg
	X			X	X	X	X	X
	X				X	X	X	X
	Black					108.2K	Infinity	241.8K
	White						Infinity	349.5K
	Blue							5.14 Meg
	Yellow							

Step 3

Re-seat the plug on the connector at the conclusion of the test.

Table of Contents

Outdoor Board Diagram 57
Outdoor Board Schematic 58
Indoor Board Diagram 62
Indoor Board Schematic 63
Module Board Schematic 65
Room and Pipe Sensor Tables 66
Ambient, Defrost and Pipe Sensor Tables 69
Discharge Sensor Tables 73

Outdoor Board Diagram

9-12K

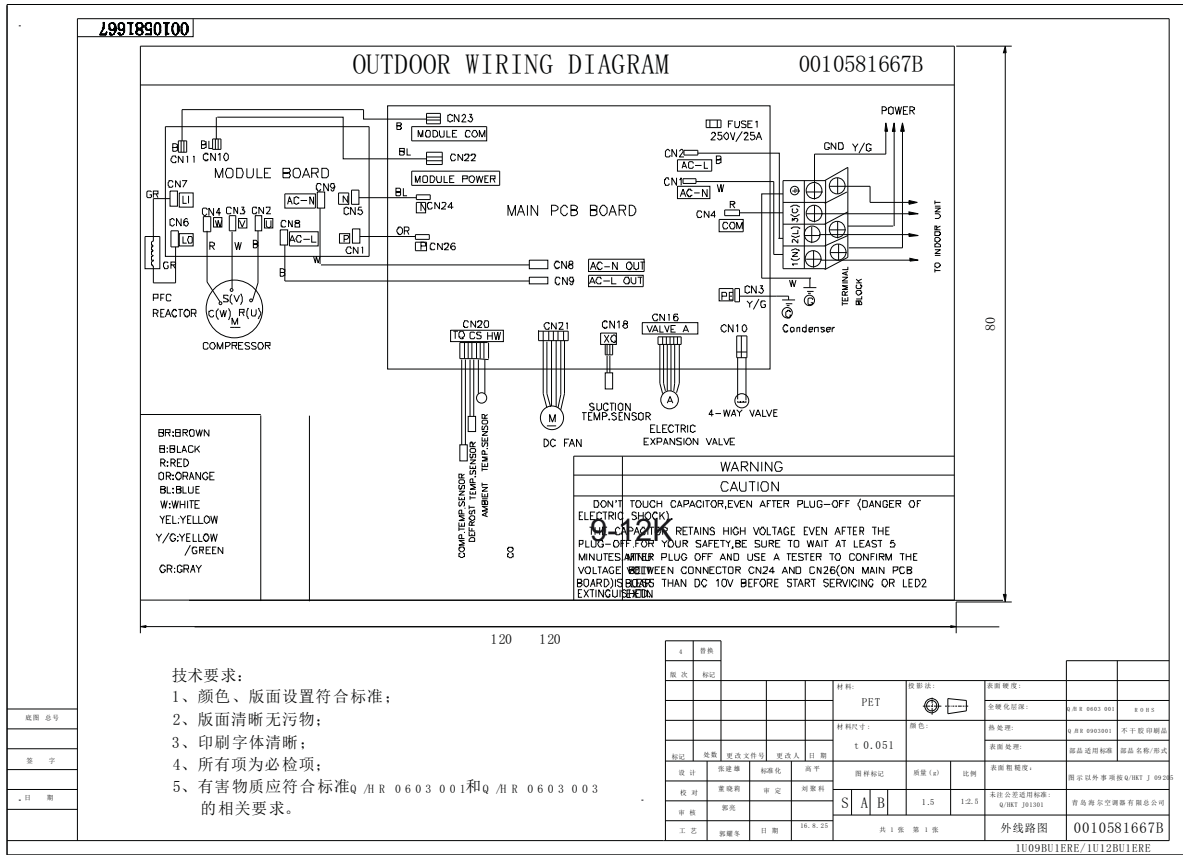

18-24K

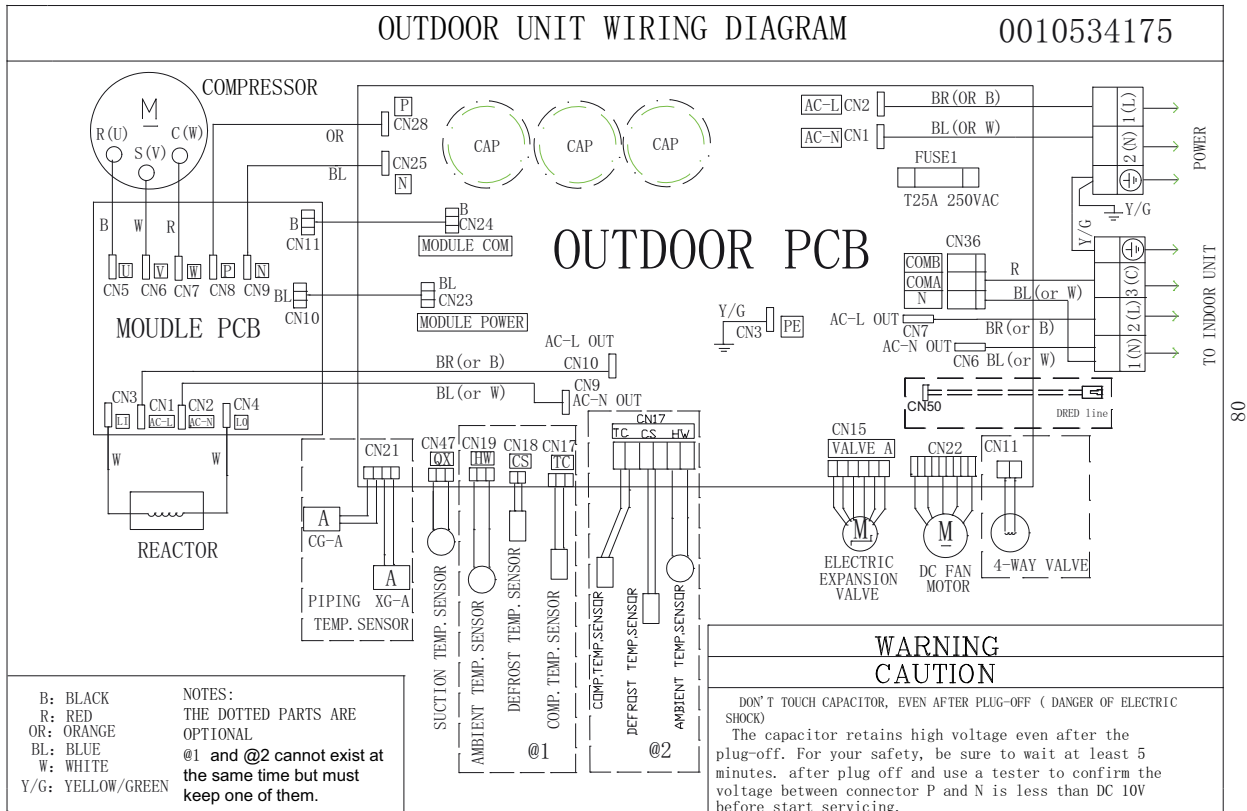

Outdoor Board Schematic

9-12K

ENGLISH

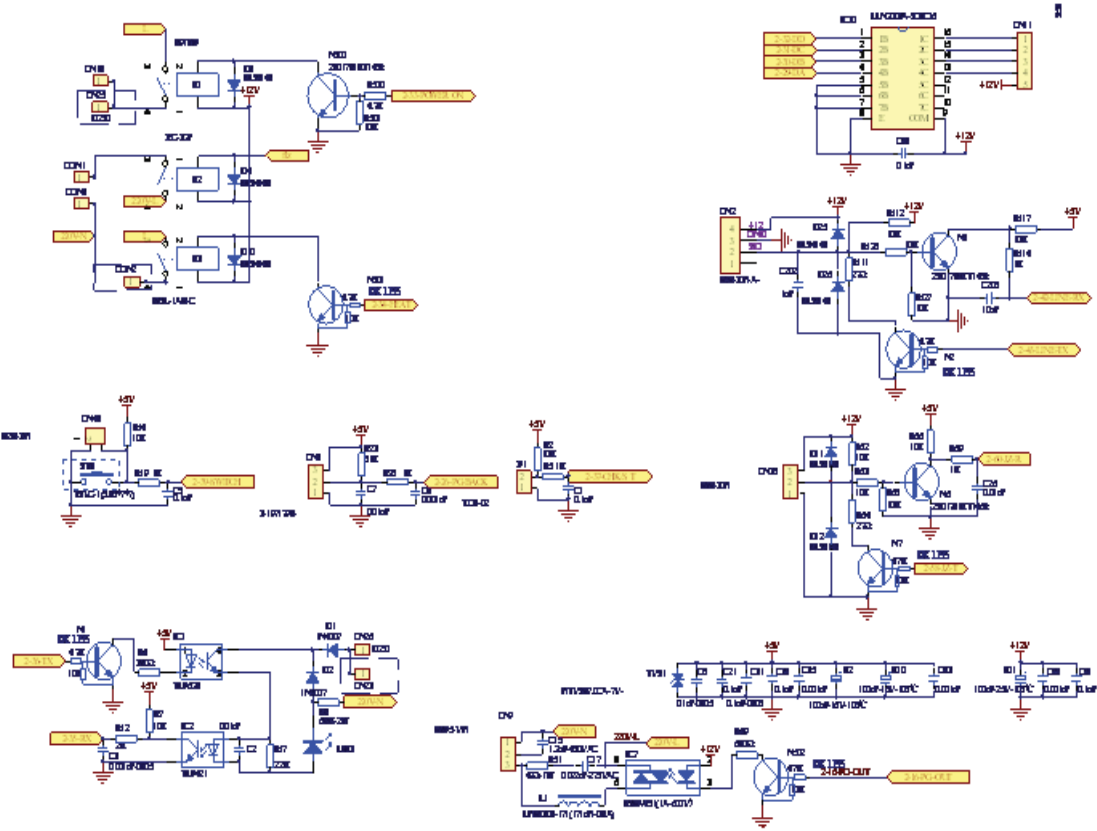
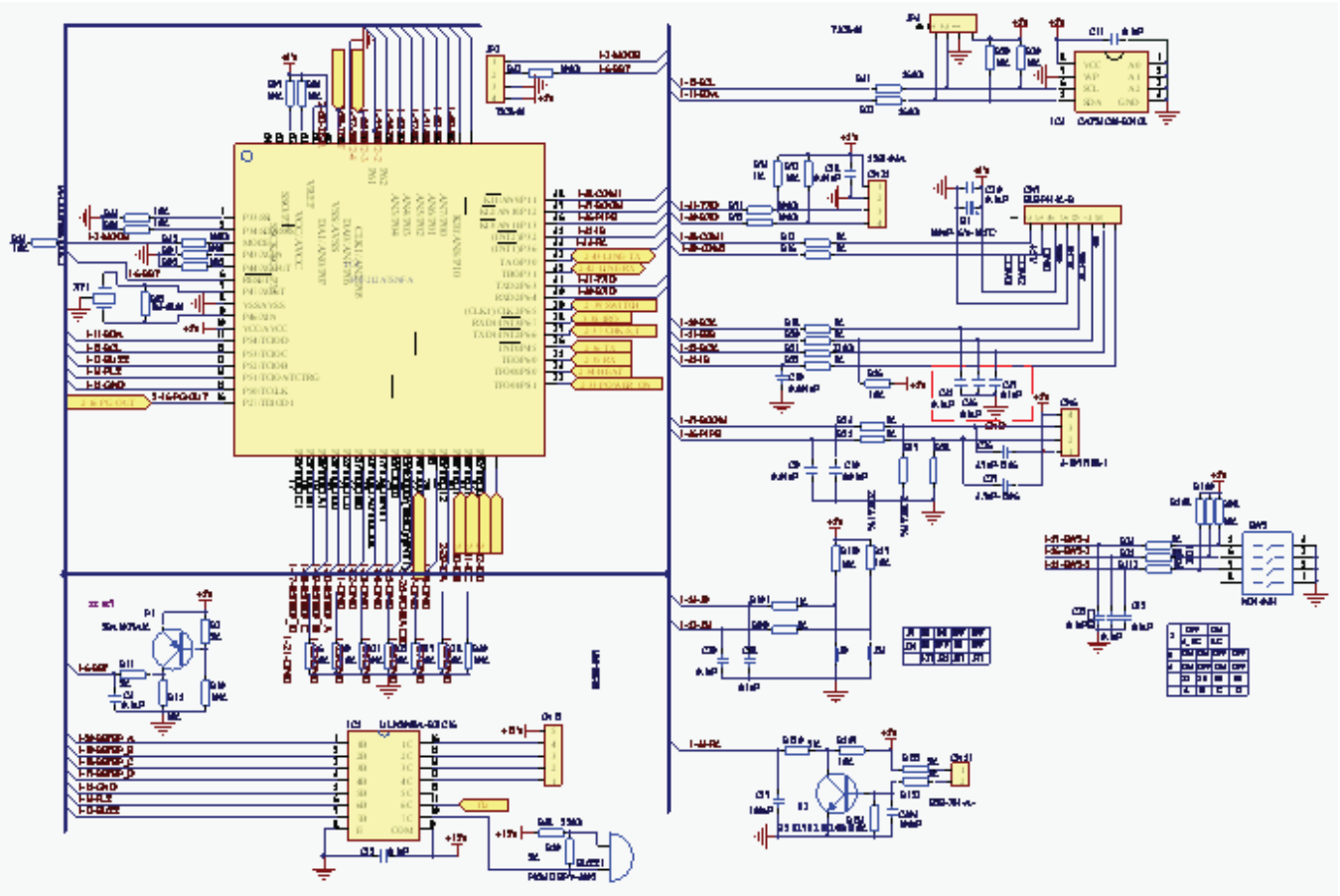

Outdoor Board Schematic

ENGLISH

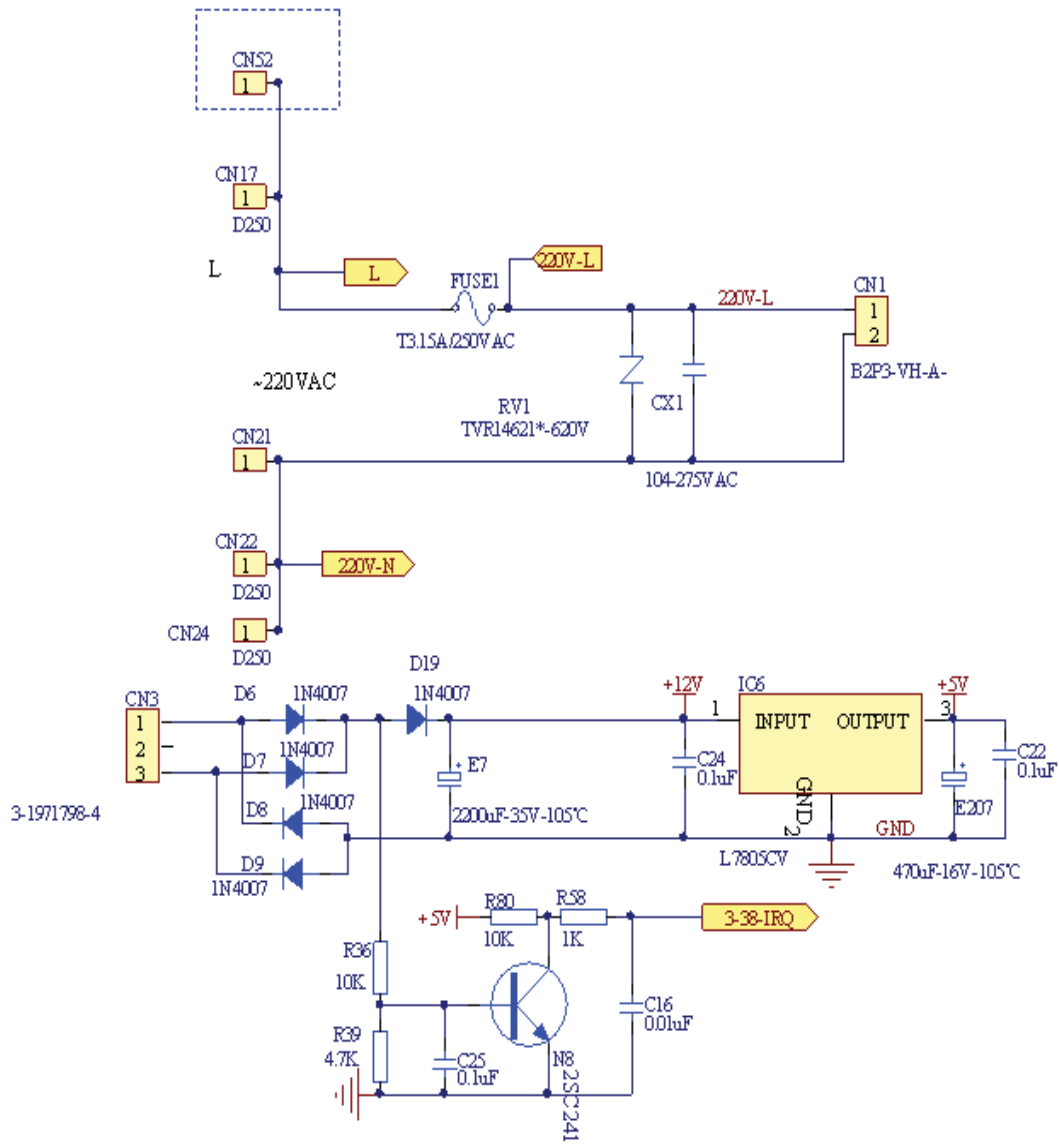

11.2. Outdoor Unit

11.2.1 Control Board Circuit Diagrams

18-24K

Outdoor Board Schematic

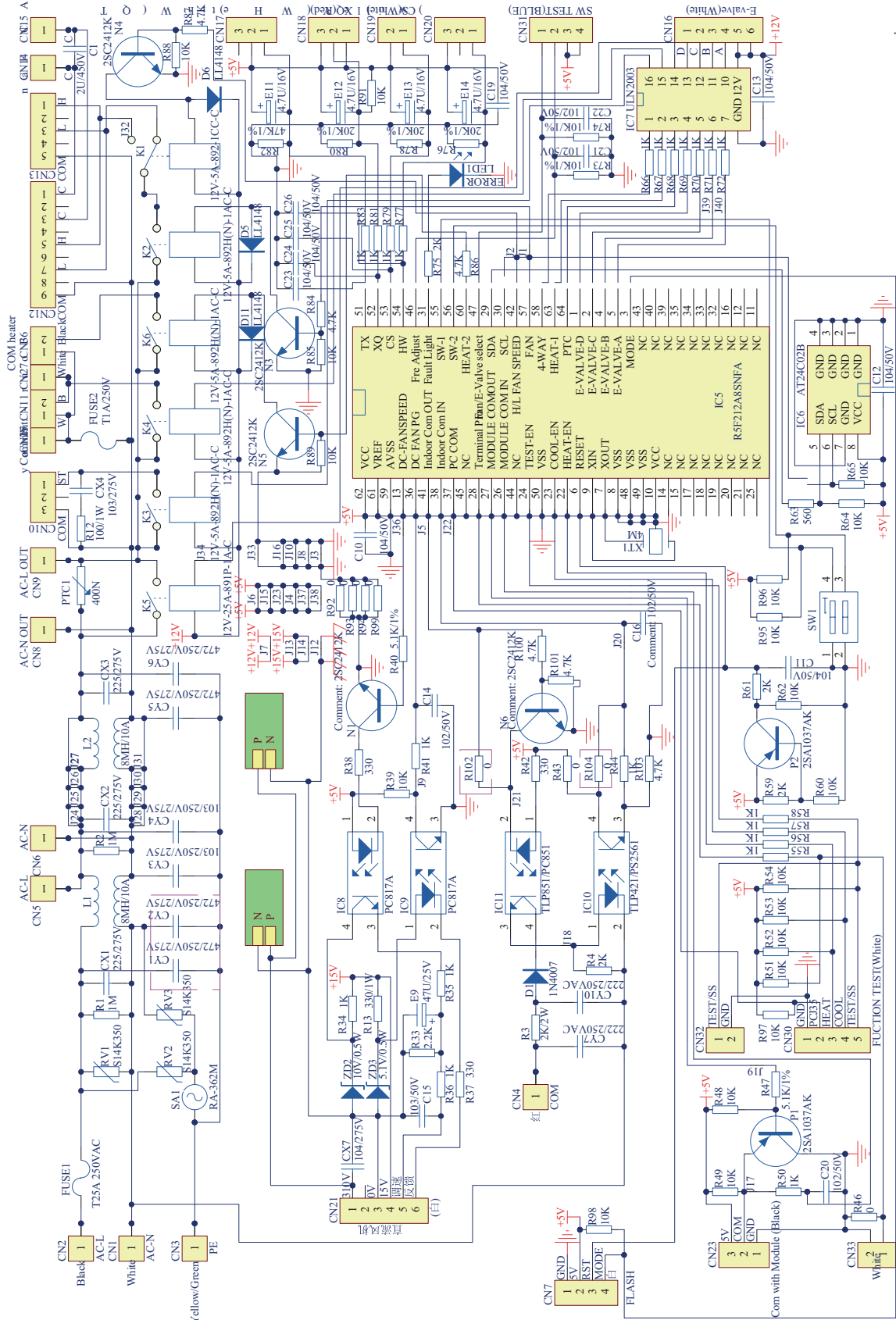

R19
47

09K-12K

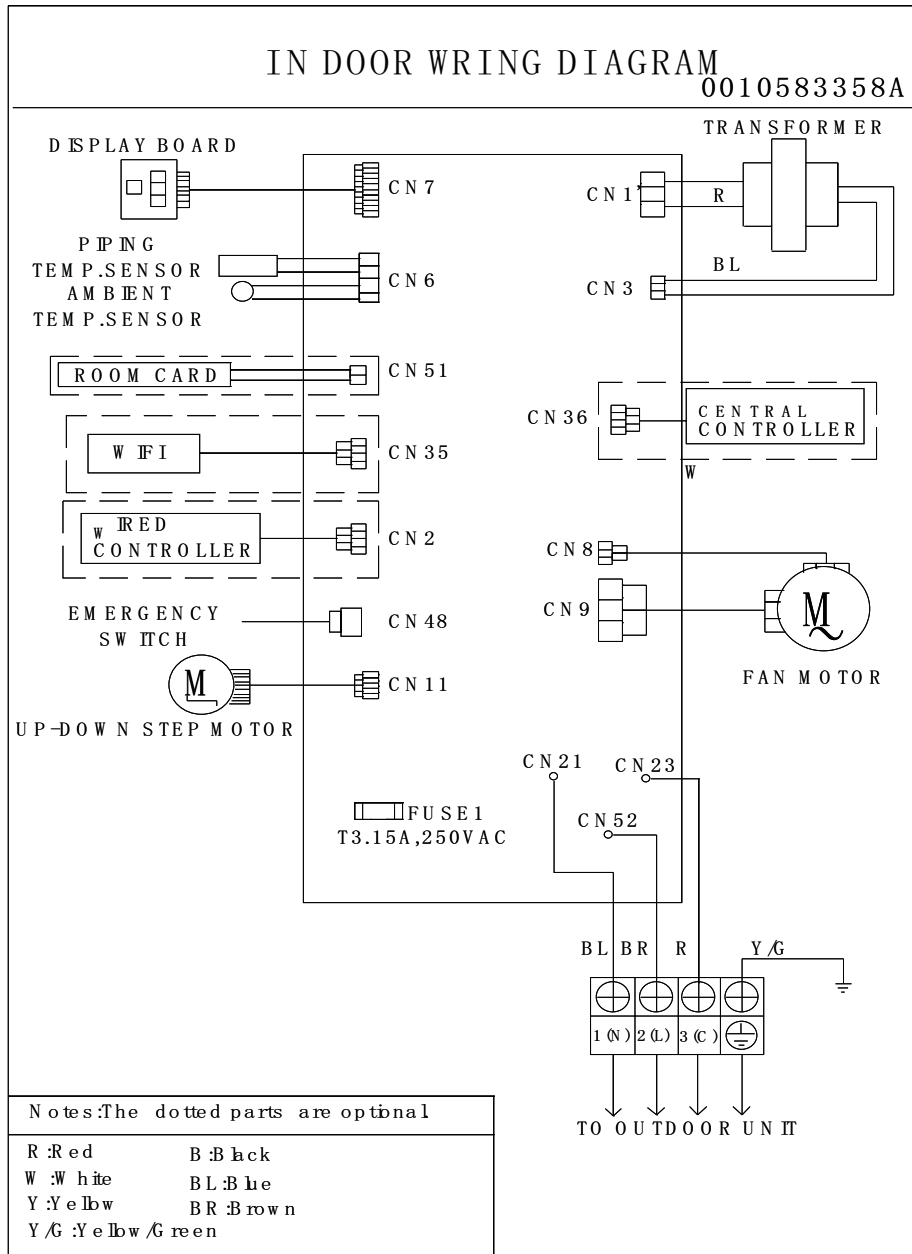

18-24K

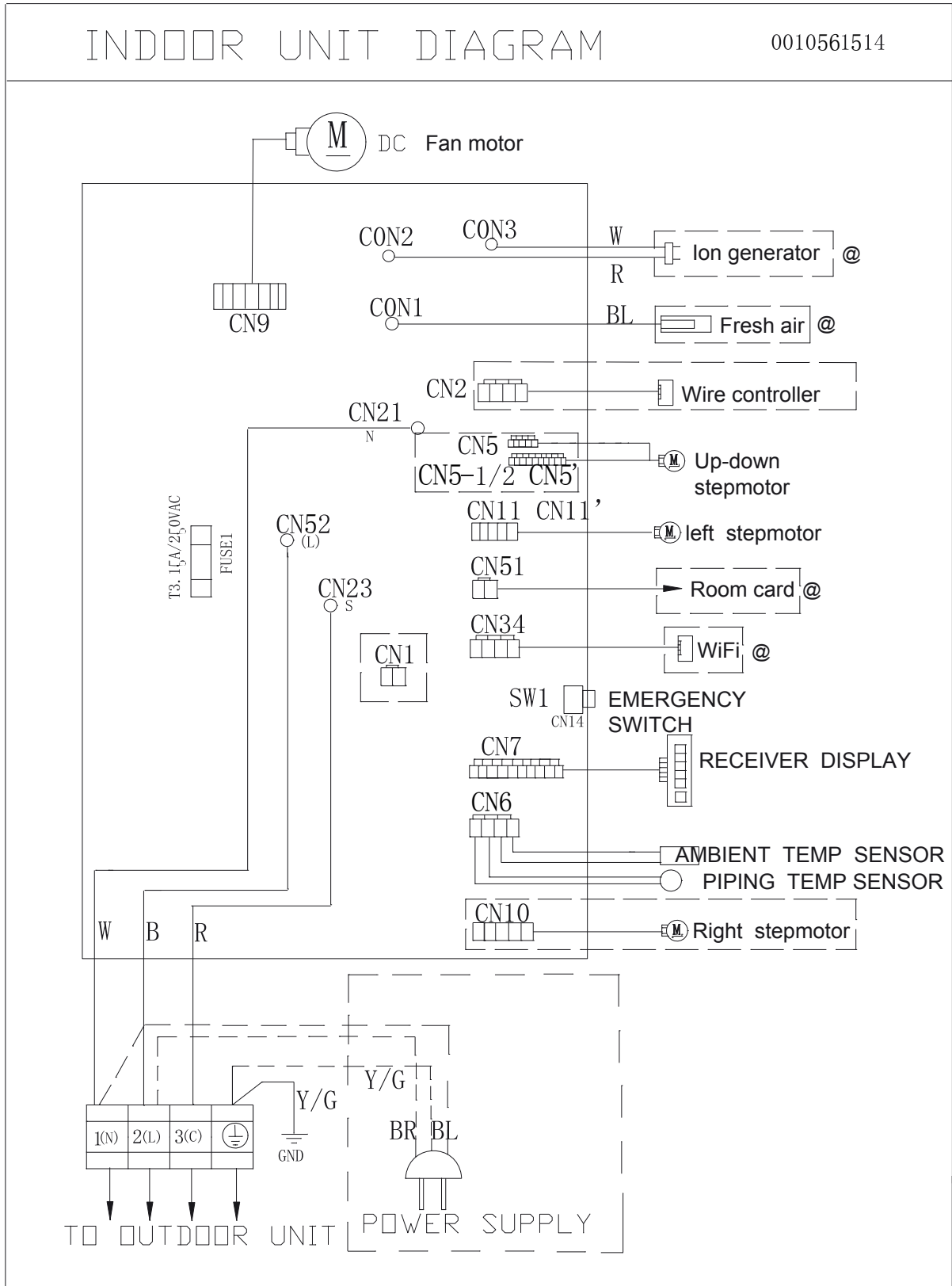

09-12K

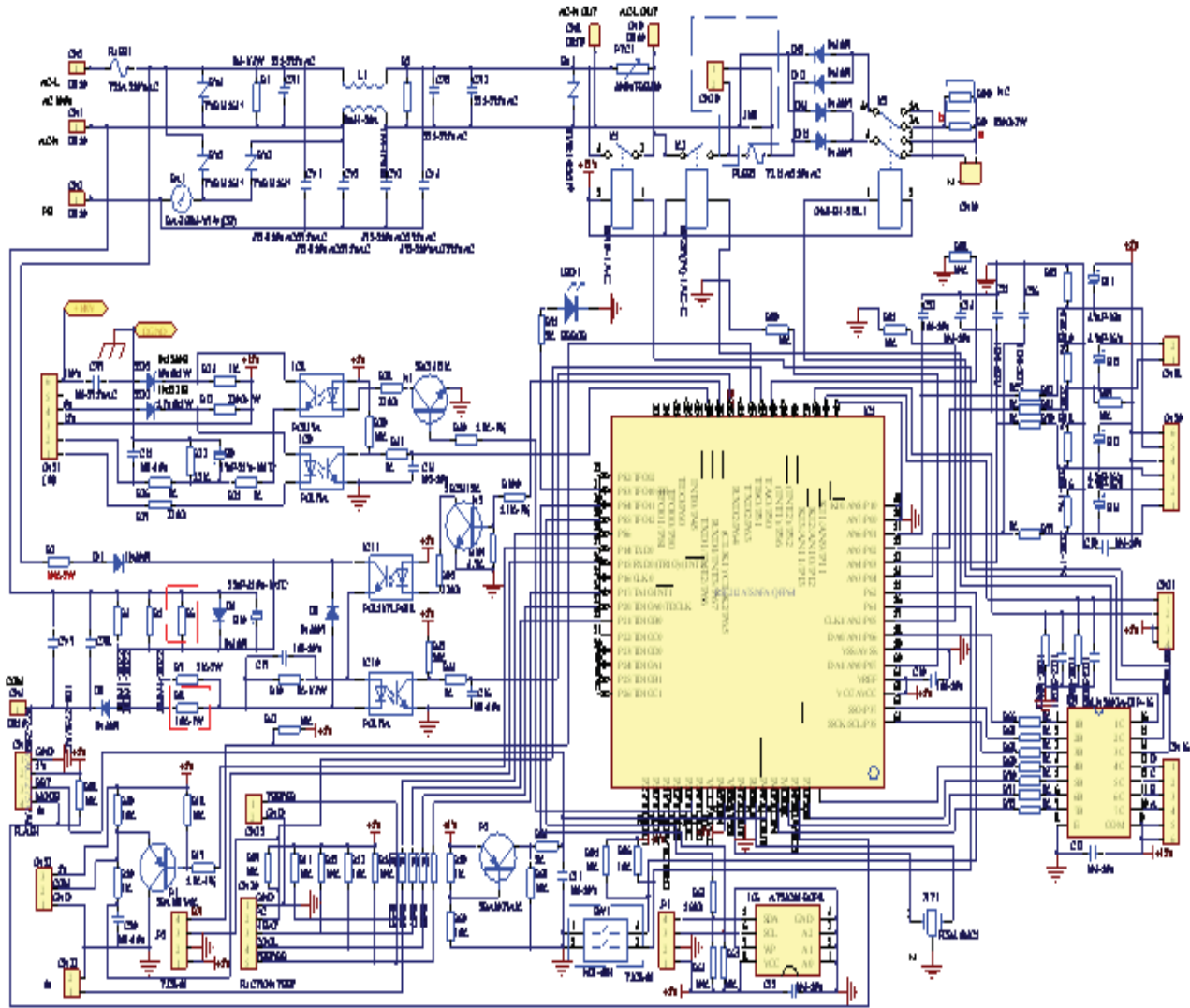

Indoor Board Schematic

18K-24K

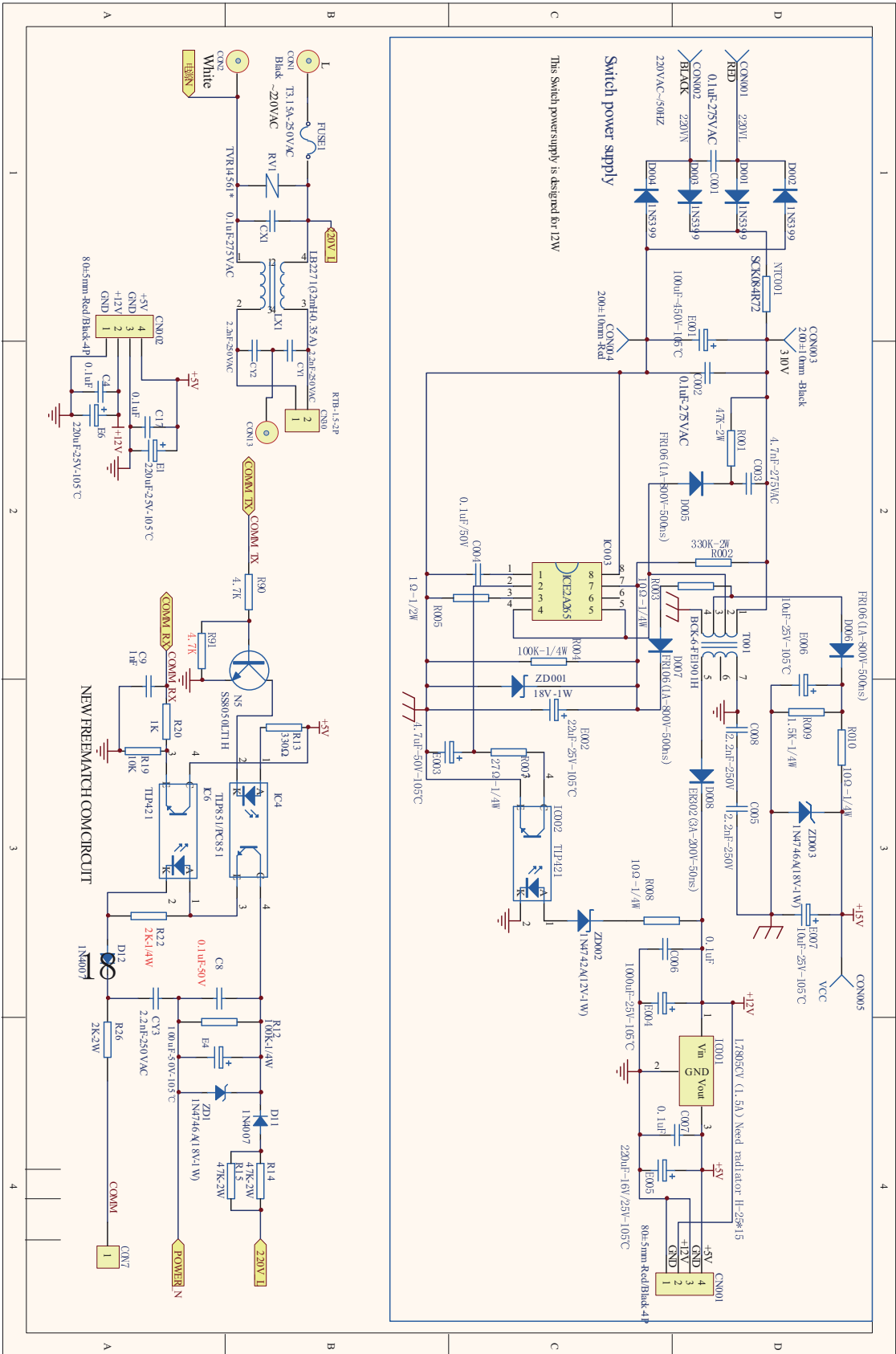

91

Domestic Heat Pump

Module Board Schematic

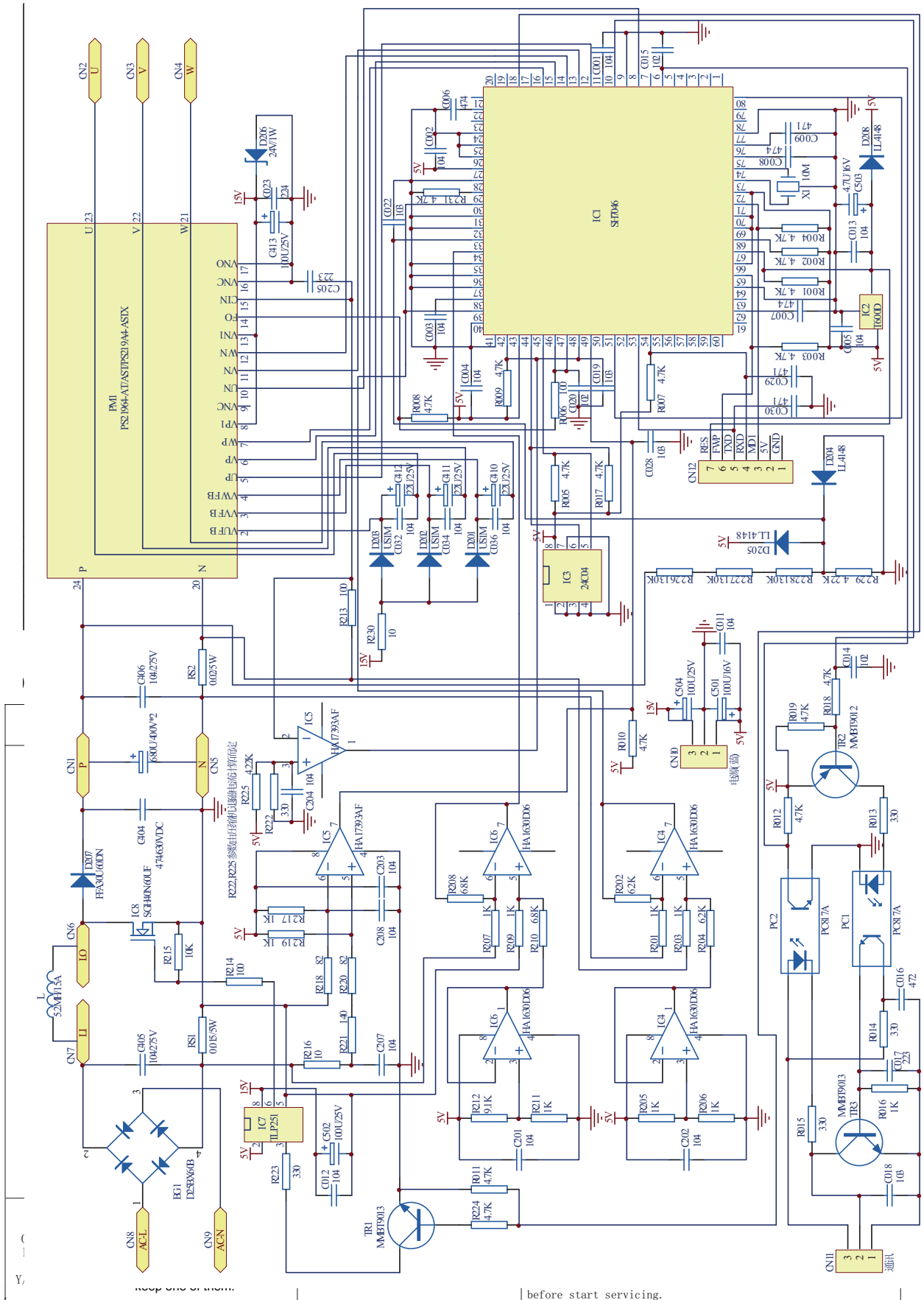

before start servicing.

Ambient Sensor Tables

9-12K

23K Ω ±3%

Temp°F	Temp. °C	Max.(K Ω)	Normal(K Ω)	Min.(K Ω)	Tolerance (°C)
-30.0	511.383	487.031	462.680	5.00	5.00
-29.0	478.574	456.022	433.470	4.95	4.95
-28.0	448.361	427.455	406.549	4.89	4.89
-27.0	420.230	400.844	381.458	4.84	4.84
-26.0	394.026	376.044	358.062	4.78	4.78
-25.0	369.606	352.922	336.238	4.73	4.73
-24.0	346.838	331.355	315.872	4.67	4.67
-23.0	325.602	311.229	296.856	4.62	4.62
-22.0	305.786	292.440	279.094	4.56	4.56
-21.0	287.287	274.892	262.497	4.51	4.51
-20.0	269.723	258.221	246.718	4.45	4.45
-19.0	253.871	243.171	232.471	4.40	4.40
-18.0	238.784	228.840	218.896	4.35	4.35
-17.0	224.677	215.433	206.189	4.29	4.29
-16.0	211.482	202.887	194.292	4.24	4.24
-15.0	199.133	191.140	183.147	4.18	4.18
-14.0	187.574	180.139	172.704	4.13	4.13
-13.0	176.749	169.832	162.915	4.07	4.07
-12.0	166.607	160.171	153.735	4.02	4.02
-11.0	157.103	151.113	145.123	3.96	3.96
-10.0	148.191	142.616	137.041	3.91	3.91
-9.0	139.834	134.644	129.454	3.85	3.85
-8.0	131.993	127.161	122.329	3.80	3.80
-7.0	124.634	120.134	115.634	3.75	3.75
-6.0	117.724	113.534	109.344	3.69	3.69
-5.0	111.235	107.332	103.429	3.64	3.64
-4.0	105.139	101.503	97.867	3.58	3.58
-3.0	99.408	96.021	92.634	3.53	3.53
-2.0	94.022	90.866	87.710	3.47	3.47
-1.0	88.955	86.015	83.075	3.42	3.42
0.0	84.220	81.479	78.739	3.36	3.36
1.0	79.704	77.151	74.598	3.31	3.31
2.0	75.481	73.102	70.723	3.25	3.25

Ambient Sensor Tables

Temp°F	Temp. °C	Max.(KΩ)	Normal(KΩ)	Min.(KΩ)	Tolerance (°C)
3.0	71.505	69.288	67.071	3.20	3.20
4.0	67.759	65.693	63.627	3.15	3.15
5.0	64.230	62.304	60.378	3.09	3.09
6.0	60.903	59.108	57.313	3.04	3.04
7.0	57.767	56.094	54.421	2.98	2.98
8.0	54.808	53.249	51.690	2.93	2.93
9.0	52.017	50.564	49.111	2.87	2.87
10.0	49.383	48.029	46.675	2.82	2.82
11.0	46.896	45.635	44.374	2.76	2.76
12.0	44.548	43.373	42.198	2.71	2.71
13.0	42.331	41.236	40.141	2.65	2.65
14.0	40.235	39.215	38.195	2.60	2.60
15.0	38.254	37.304	36.354	2.55	2.55
16.0	36.381	35.497	34.613	2.49	2.49
17.0	34.611	33.788	32.965	2.44	2.44
18.0	32.935	32.169	31.403	2.38	2.38
19.0	31.351	30.638	29.925	2.33	2.33
20.0	29.850	29.187	28.524	2.27	2.27
21.0	28.430	27.813	27.196	2.22	2.22
22.0	27.086	26.512	25.938	2.16	2.16
23.0	25.811	25.278	24.745	2.11	2.11
24.0	24.604	24.109	23.614	2.05	2.05
25.0	23.460	23.000	22.540	2.00	2.00
26.0	22.397	21.948	21.499	2.04	2.04
27.0	21.387	20.950	20.513	2.09	2.09
28.0	20.429	20.003	19.577	2.13	2.13
29.0	19.521	19.105	18.689	2.18	2.18
30.0	18.656	18.251	17.846	2.22	2.22
31.0	17.835	17.440	17.045	2.26	2.26
32.0	17.054	16.670	16.286	2.31	2.31
33.0	16.313	15.938	15.563	2.35	2.35
34.0	15.608	15.243	14.878	2.39	2.39
35.0	14.936	14.581	14.226	2.44	2.44
36.0	14.299	13.953	13.607	2.48	2.48
37.0	13.691	13.354	13.017	2.53	2.53
38.0	13.113	12.785	12.457	2.57	2.57

Ambient Sensor Tables

Temp°F	Temp. °C	Max.(KΩ)	Normal(KΩ)	Min.(KΩ)	Tolerance (°C)
39.0	12.563	12.243	11.923	2.61	2.61
40.0	12.038	11.727	11.416	2.66	2.66
41.0	11.539	11.236	10.933	2.70	2.70
42.0	11.063	10.768	10.473	2.74	2.74
43.0	10.611	10.323	10.035	2.79	2.79
44.0	10.178	9.898	9.618	2.83	2.83
45.0	9.766	9.493	9.220	2.88	2.88
46.0	9.373	9.107	8.841	2.92	2.92
47.0	8.998	8.739	8.480	2.96	2.96
48.0	8.640	8.388	8.136	3.01	3.01
49.0	8.299	8.053	7.807	3.05	3.05
50.0	7.974	7.734	7.495	3.09	3.09
51.0	7.661	7.428	7.195	3.14	3.14
52.0	7.363	7.136	6.909	3.18	3.18
53.0	7.079	6.858	6.637	3.23	3.23
54.0	6.807	6.592	6.377	3.27	3.27
55.0	6.547	6.337	6.127	3.31	3.31
56.0	6.300	6.095	5.890	3.36	3.36
57.0	6.061	5.862	5.663	3.40	3.40
58.0	5.834	5.640	5.446	3.44	3.44
59.0	5.617	5.428	5.239	3.49	3.49
60.0	5.410	5.225	5.040	3.53	3.53
61.0	5.210	5.030	4.850	3.58	3.58
62.0	5.019	4.844	4.669	3.62	3.62
63.0	4.837	4.666	4.495	3.66	3.66
64.0	4.662	4.495	4.328	3.71	3.71
65.0	4.494	4.332	4.170	3.75	3.75
66.0	4.333	4.175	4.017	3.79	3.79
67.0	4.179	4.025	3.871	3.84	3.84
68.0	4.032	3.881	3.730	3.88	3.88
69.0	3.890	3.743	3.596	3.93	3.93
70.0	3.754	3.611	3.468	3.97	3.97
71.0	3.624	3.484	3.344	4.01	4.01
72.0	3.498	3.362	3.226	4.06	4.06
73.0	3.378	3.245	3.112	4.10	4.10
74.0	3.263	3.133	3.003	4.14	4.14

Ambient Sensor Tables

Temp°F	Temp. °C	Max.(KΩ)	Normal(KΩ)	Min.(KΩ)	Tolerance (°C)
75.0	3.153	3.026	2.899	4.19	4.19
76.0	3.046	2.922	2.798	4.23	4.23
77.0	2.944	2.823	2.702	4.28	4.28
78.0	2.845	2.727	2.609	4.32	4.32
79.0	2.751	2.636	2.521	4.36	4.36
80.0	2.659	2.547	2.435	4.41	4.41
81.0	2.573	2.463	2.353	4.45	4.45
82.0	2.488	2.381	2.274	4.49	4.49
83.0	2.407	2.303	2.199	4.54	4.54
84.0	2.329	2.227	2.125	4.58	4.58
85.0	2.253	2.154	2.054	4.63	4.63
86.0	2.182	2.085	1.988	4.67	4.67
87.0	2.112	2.017	1.922	4.71	4.71
88.0	2.046	1.953	1.860	4.76	4.76
89.0	1.981	1.890	1.799	4.80	4.80
90.0	1.919	1.830	1.741	4.84	4.84
91.0	1.859	1.772	1.685	4.89	4.89
92.0	1.801	1.716	1.631	4.93	4.93
93.0	1.745	1.662	1.579	4.98	4.98
94.0	1.691	1.610	1.529	5.02	5.02
95.0	1.639	1.560	1.481	5.06	5.06
96.0	1.589	1.512	1.435	5.11	5.11
97.0	1.540	1.465	1.390	5.15	5.15
98.0	1.494	1.420	1.346	5.19	5.19
99.0	1.449	1.377	1.305	5.24	5.24
100.0	1.406	1.335	1.264	5.28	5.28
101.0	1.363	1.294	1.225	5.33	5.33
102.0	1.322	1.255	1.188	5.37	5.37
103.0	1.283	1.217	1.151	5.41	5.41
104.0	1.244	1.180	1.116	5.46	5.46
105.0	1.208	1.145	1.082	5.50	5.50

Pipe Sensor Tables

18-24K

R77° = 10KΩ±3%

B77°/122° = 3700K±3%

Temp. °F	Temp. °C	Max.(KΩ)	Normal(KΩ)	Min.(KΩ)	Tolerance (°C)	
-22	-30	165.217	147.9497	132.3678	-1.94	1.75
-20.2	-29	155.5754	139.56	125.0806	-1.93	1.74
-18.4	-28	146.5609	131.7022	118.2434	-1.91	1.73
-16.6	-27	138.1285	124.3392	111.8256	-1.89	1.71
-14.8	-26	130.2371	117.4366	105.7989	-1.87	1.7
-13	-25	122.8484	110.9627	100.1367	-1.85	1.69
-11.2	-24	115.9272	104.8882	94.8149	-1.83	1.67
-9.4	-23	109.441	99.1858	89.8106	-1.81	1.66
-7.6	-22	103.3598	93.8305	85.1031	-1.8	1.64
-5.8	-21	97.6556	88.7989	80.6728	-1.78	1.63
-4	-20	92.3028	84.0695	76.5017	-1.76	1.62
-2.2	-19	87.2775	79.6222	72.5729	-1.74	1.6
-0.4	-18	82.5577	75.4384	68.871	-1.72	1.59
1.4	-17	78.123	71.501	65.3815	-1.7	1.57
3.2	-16	73.9543	67.7939	62.0907	-1.68	1.55
5	-15	70.0342	64.3023	58.9863	-1.66	1.54
6.8	-14	66.3463	61.0123	56.0565	-1.64	1.52
8.6	-13	62.8755	57.911	53.2905	-1.62	1.51
10.4	-12	59.6076	54.9866	50.6781	-1.6	1.49
12.2	-11	56.5296	52.2278	48.2099	-1.58	1.47
14	-10	53.6294	49.6244	45.8771	-1.56	1.46
15.8	-9	50.8956	47.1666	43.6714	-1.54	1.44
17.6	-8	48.3178	44.8454	41.5851	-1.51	1.42
19.4	-7	45.886	42.6525	39.6112	-1.49	1.4
21.2	-6	43.5912	40.58	37.7429	-1.47	1.39
23	-5	41.4249	38.6207	35.9739	-1.45	1.37
24.8	-4	39.3792	36.7676	34.2983	-1.43	1.35
26.6	-3	37.4465	35.0144	32.7108	-1.41	1.33
28.4	-2	35.6202	33.3552	31.2062	-1.38	1.31
30.2	-1	33.8936	31.7844	29.7796	-1.36	1.29
32	0	32.2608	30.2968	28.4267	-1.34	1.28
33.8	1	30.7162	28.8875	27.1431	-1.32	1.26
35.6	2	29.2545	27.5519	25.925	-1.29	1.24
37.4	3	27.8708	26.2858	24.7686	-1.27	1.22
39.2	4	26.5605	25.0851	23.6704	-1.25	1.2
41	5	25.3193	23.9462	22.6273	-1.23	1.18
42.8	6	24.1432	22.8656	21.6361	-1.2	1.16
44.6	7	23.0284	21.8398	20.6939	-1.18	1.14
46.4	8	21.9714	20.8659	19.7982	-1.15	1.12
48.2	9	20.9688	19.9409	18.9463	-1.13	1.09
50	10	20.0176	19.0621	18.1358	-1.11	1.07
51.8	11	19.1149	18.227	17.3646	-1.08	1.05
53.6	12	18.258	17.4331	16.6305	-1.06	1.03
55.4	13	17.4442	16.6782	15.9315	-1.03	1.01
57.2	14	16.6711	15.9601	15.2657	-1.01	0.99
59	15	15.9366	15.277	14.6315	-0.98	0.96
60.8	16	15.2385	14.6268	14.0271	-0.96	0.9418-254

Pipe Sensor Tables

Temp. °F	Temp. °C	Max.(KΩ)	Normal(KΩ)	Min.(KΩ)	Tolerance (°C)	
62.6	17	14.5748	14.0079	13.451	-0.93	0.92
64.4	18	13.9436	13.4185	12.9017	-0.91	0.9
66.2	19	13.3431	12.8572	12.3778	-0.88	0.87
68	20	12.7718	12.3223	11.878	-0.86	0.85
69.8	21	12.228	11.8126	11.4011	-0.83	0.83
71.6	22	11.7102	11.3267	10.9459	-0.81	0.8
73.4	23	11.2172	10.8634	10.5114	-0.78	0.78
75.2	24	10.7475	10.4216	10.0964	-0.75	0.75
77	25	10.3	10	9.7	-0.75	0.75
78.8	26	9.8975	9.5974	9.298	-0.76	0.76
80.6	27	9.5129	9.2132	8.9148	-0.8	0.8
82.4	28	9.1454	8.8465	8.5496	-0.84	0.83
84.2	29	8.7942	8.4964	8.2013	-0.87	0.86
86	30	8.4583	8.1621	7.8691	-0.91	0.9
87.8	31	8.1371	7.8428	7.5522	-0.95	0.93
89.6	32	7.8299	7.5377	7.2498	-0.98	0.97
91.4	33	7.5359	7.2461	6.9611	-1.02	1
93.2	34	7.2546	6.9673	6.6854	-1.06	1.04
95	35	6.9852	6.7008	6.4222	-1.1	1.07
96.8	36	6.7273	6.4459	6.1707	-1.13	1.11
98.6	37	6.4803	6.2021	5.9304	-1.17	1.14
100.4	38	6.2437	5.9687	5.7007	-1.21	1.18
102.2	39	6.017	5.7454	5.4812	-1.25	1.22
104	40	5.7997	5.5316	5.2712	-1.29	1.25
105.8	41	5.5914	5.3269	5.0704	-1.33	1.29
107.6	42	5.3916	5.1308	4.8783	-1.37	1.33
109.4	43	5.2001	4.943	4.6944	-1.41	1.36
111.2	44	5.0163	4.763	4.5185	-1.45	1.4
113	45	4.84	4.5905	4.35	-1.49	1.44
114.8	46	4.6708	4.4252	4.1887	-1.53	1.47
116.6	47	4.5083	4.2666	4.0342	-1.57	1.51
118.4	48	4.3524	4.1145	3.8862	-1.61	1.55
120.2	49	4.2026	3.9686	3.7443	-1.65	1.59
122	50	4.0588	3.8287	3.6084	-1.7	1.62
123.8	51	3.9206	3.6943	3.478	-1.74	1.66
125.6	52	3.7878	3.5654	3.3531	-1.78	1.7
127.4	53	3.6601	3.4416	3.2332	-1.82	1.74
129.2	54	3.5374	3.3227	3.1183	-1.87	1.78
131	55	3.4195	3.2085	3.0079	-1.91	1.82
132.8	56	3.306	3.0989	2.9021	-1.95	1.85
134.6	57	3.1969	2.9935	2.8005	-2	1.89
136.4	58	3.0919	2.8922	2.7029	-2.04	1.93
138.2	59	2.9909	2.7948	2.6092	-2.08	1.97
140	60	2.8936	2.7012	2.5193	-2.13	2.01
141.8	61	2.8	2.6112	2.4328	-2.17	2.05
143.6	62	2.7099	2.5246	2.3498	-2.22	2.09
145.4	63	2.6232	2.4413	2.27	-2.26	2.13
147.2	64	2.5396	2.3611	2.1932	-2.31	2.17

Pipe Sensor Tables

Temp. °F	Temp. °C	Max.(KΩ)	Normal(KΩ)	Min.(KΩ)	Tolerance (°C)	
149	65	2.4591	2.284	2.1195	-2.36	2.21
150.8	66	2.3815	2.2098	2.0486	-2.4	2.25
152.6	67	2.3068	2.1383	1.9803	-2.45	2.29
154.4	68	2.2347	2.0695	1.9147	-2.49	2.34
156.2	69	2.1652	2.0032	1.8516	-2.54	2.38
158	70	2.0983	1.9393	1.7908	-2.59	2.42
159.8	71	2.0337	1.8778	1.7324	-2.63	2.46
161.6	72	1.9714	1.8186	1.6761	-2.68	2.5
163.4	73	1.9113	1.7614	1.6219	-2.73	2.54
165.2	74	1.8533	1.7064	1.5697	-2.78	2.58
167	75	1.7974	1.6533	1.5194	-2.83	2.63
168.8	76	1.7434	1.6021	1.471	-2.88	2.67
170.6	77	1.6913	1.5528	1.4243	-2.92	2.71
172.4	78	1.6409	1.5051	1.3794	-2.97	2.75
174.2	79	1.5923	1.4592	1.336	-3.02	2.8
176	80	1.5454	1.4149	1.2942	-3.07	2.84
177.8	81	1.5	1.3721	1.254	-3.12	2.88
179.6	82	1.4562	1.3308	1.2151	-3.17	2.93
181.4	83	1.4139	1.291	1.1776	-3.22	2.97
183.2	84	1.373	1.2525	1.1415	-3.27	3.01
185	85	1.3335	1.2153	1.1066	-3.32	3.06
186.8	86	1.2953	1.1794	1.073	-3.38	3.1
188.6	87	1.2583	1.1448	1.0405	-3.43	3.15
190.4	88	1.2226	1.1113	1.0092	-3.48	3.19
192.2	89	1.188	1.0789	0.9789	-3.53	3.24
194	90	1.1546	1.0476	0.9497	-3.58	3.28
195.8	91	1.1223	1.0174	0.9215	-3.64	3.33
197.6	92	1.091	0.9882	0.8942	-3.69	3.37
199.4	93	1.0607	0.9599	0.8679	-3.74	3.42
201.2	94	1.0314	0.9326	0.8424	-3.8	3.46
203	95	1.003	0.9061	0.8179	-3.85	3.51
204.8	96	0.9756	0.8806	0.7941	-3.9	3.55
206.6	97	0.949	0.8558	0.7711	-3.96	3.6
208.4	98	0.9232	0.8319	0.7489	-4.01	3.64
210.2	99	0.8983	0.8088	0.7275	-4.07	3.69
212	100	0.8741	0.7863	0.7067	-4.12	3.74
213.8	101	0.8507	0.7646	0.6867	-4.18	3.78
215.6	102	0.8281	0.7436	0.6672	-4.23	3.83
217.4	103	0.8061	0.7233	0.6484	-4.29	3.88
219.2	104	0.7848	0.7036	0.6303	-4.34	3.92
221	105	0.7641	0.6845	0.6127	-4.4	3.97
222.8	106	0.7441	0.6661	0.5957	-4.46	4.02
224.6	107	0.7247	0.6482	0.5792	-4.51	4.07
226.4	108	0.7059	0.6308	0.5632	-4.57	4.12
228.2	109	0.6877	0.614	0.5478	-4.63	4.16
230	110	0.67	0.5977	0.5328	-4.69	4.21
231.8	111	0.6528	0.582	0.5183	-4.74	4.26
233.6	112	0.6361	0.5667	0.5043	-4.8	4.31

Ambient and Pipe Sensor Tables

Temp.	°F	Temp.	°C	Max.(KΩ)	Normal(KΩ)	Min.(KΩ)	Tolerance
235.4	113	0.62	0.5518	0.4907	-4.86	4.36	
237.2	114	0.6043	0.5374	0.4775	-4.92	4.41	
239	115	0.5891	0.5235	0.4648	-4.98	4.45	
240.8	116	0.5743	0.51	0.4524	-5.04	4.5	
242.6	117	0.56	0.4968	0.4404	-5.1	4.55	
244.4	118	0.546	0.4841	0.4288	-5.16	4.6	
246.2	119	0.5325	0.4717	0.4175	-5.22	4.65	
248	120	0.5194	0.4597	0.4066	-5.28	4.7	

Ambient, Defrost and Pipe Sensor Tables

Temp.	°F	Temp.	°C	Max.(KΩ)	Normal(KΩ)	Min.(KΩ)	Tolerance
-22	-30	165.2170	147.9497	132.3678	-1.94	1.75	
-20	-29	155.5754	139.5600	125.0806	-1.93	1.74	
-18	-28	146.5609	131.7022	118.2434	-1.91	1.73	
-17	-27	138.1285	124.3392	111.8256	-1.89	1.71	
-15	-26	130.2371	117.4366	105.7989	-1.87	1.70	
-13	-25	122.8484	110.9627	100.1367	-1.85	1.69	
-11	-24	115.9272	104.8882	94.8149	-1.83	1.67	
-9	-23	109.4410	99.1858	89.8106	-1.81	1.66	
-8	-22	103.3598	93.8305	85.1031	-1.80	1.64	
-6	-21	97.6556	88.7989	80.6728	-1.78	1.63	
-4	-20	92.3028	84.0695	76.5017	-1.76	1.62	
-2	-19	87.2775	79.6222	72.5729	-1.74	1.60	
0	-18	82.5577	75.4384	68.8710	-1.72	1.59	
1	-17	78.1230	71.5010	65.3815	-1.70	1.57	
3	-16	73.9543	67.7939	62.0907	-1.68	1.55	
5	-15	70.0342	64.3023	58.9863	-1.66	1.54	
7	-14	66.3463	61.0123	56.0565	-1.64	1.52	
9	-13	62.8755	57.9110	53.2905	-1.62	1.51	
10	-12	59.6076	54.9866	50.6781	-1.60	1.49	
12	-11	56.5296	52.2278	48.2099	-1.58	1.47	
14	-10	53.6294	49.6244	45.8771	-1.56	1.46	
16	-9	50.8956	47.1666	43.6714	-1.54	1.44	
18	-8	48.3178	44.8454	41.5851	-1.51	1.42	
19	-7	45.8860	42.6525	39.6112	-1.49	1.40	
21	-6	43.5912	40.5800	37.7429	-1.47	1.39	
23	-5	41.4249	38.6207	35.9739	-1.45	1.37	
25	-4	39.3792	36.7676	34.2983	-1.43	1.35	
27	-3	37.4465	35.0144	32.7108	-1.41	1.33	
28	-2	35.6202	33.3552	31.2062	-1.38	1.31	
30	-1	33.8936	31.7844	29.7796	-1.36	1.29	
32	0	32.2608	30.2968	28.4267	-1.34	1.28	
34	1	30.7162	28.8875	27.1431	-1.32	1.26	
36	2	29.2545	27.5519	25.9250	-1.29	1.24	
37	3	27.8708	26.2858	24.7686	-1.27	1.22	
39	4	26.5605	25.0851	23.6704	-1.25	1.20	
41	5	25.3193	23.9462	22.6273	-1.23	1.18	
43	6	24.1432	22.8656	21.6361	-1.20	1.16	

Ambient, Defrosting and Pipe Sensor Tables

Temp.	°F	Temp.	°C	Max.(KΩ)	Normal(KΩ)	Min.(KΩ)	Tolerance	(°C)
45	7	23.0284	21.8398	20.6939	-1.18	1.14		
46	8	21.9714	20.8659	19.7982	-1.15	1.12		
48	9	20.9688	19.9409	18.9463	-1.13	1.09		
50	10	20.0176	19.0621	18.1358	-1.11	1.07		
52	11	19.1149	18.2270	17.3646	-1.08	1.05		
54	12	18.2580	17.4331	16.6305	-1.06	1.03		
55	13	17.4442	16.6782	15.9315	-1.03	1.01		
57	14	16.6711	15.9601	15.2657	-1.01	0.99		
59	15	15.9366	15.2770	14.6315	-0.98	0.96		
61	16	15.2385	14.6268	14.0271	-0.96	0.94		
63	17	14.5748	14.0079	13.4510	-0.93	0.92		
64	18	13.9436	13.4185	12.9017	-0.91	0.90		
66	19	13.3431	12.8572	12.3778	-0.88	0.87		
68	20	12.7718	12.3223	11.8780	-0.86	0.85		
70	21	12.2280	11.8126	11.4011	-0.83	0.83		
72	22	11.7102	11.3267	10.9459	-0.81	0.80		
73	23	11.2172	10.8634	10.5114	-0.78	0.78		
75	24	10.7475	10.4216	10.0964	-0.75	0.75		
77	25	10.3000	10.0000	9.7000	-0.75	0.75		
79	26	9.8975	9.5974	9.2980	-0.76	0.76		
81	27	9.5129	9.2132	8.9148	-0.80	0.80		
82	28	9.1454	8.8465	8.5496	-0.84	0.83		
84	29	8.7942	8.4964	8.2013	-0.87	0.86		
86	30	8.4583	8.1621	7.8691	-0.91	0.90		
88	31	8.1371	7.8428	7.5522	-0.95	0.93		
90	32	7.8299	7.5377	7.2498	-0.98	0.97		
91	33	7.5359	7.2461	6.9611	-1.02	1.00		
93	34	7.2546	6.9673	6.6854	-1.06	1.04		
95	35	6.9852	6.7008	6.4222	-1.10	1.07		
97	36	6.7273	6.4459	6.1707	-1.13	1.11		
99	37	6.4803	6.2021	5.9304	-1.17	1.14		
100	38	6.2437	5.9687	5.7007	-1.21	1.18		
102	39	6.0170	5.7454	5.4812	-1.25	1.22		
104	40	5.7997	5.5316	5.2712	-1.29	1.25		
106	41	5.5914	5.3269	5.0704	-1.33	1.29		
108	42	5.3916	5.1308	4.8783	-1.37	1.33		
109	43	5.2001	4.9430	4.6944	-1.41	1.36		
111	44	5.0163	4.7630	4.5185	-1.45	1.40		
113	45	4.8400	4.5905	4.3500	-1.49	1.44		
115	46	4.6708	4.4252	4.1887	-1.53	1.47		
117	47	4.5083	4.2666	4.0342	-1.57	1.51		
118	48	4.3524	4.1145	3.8862	-1.61	1.55		
120	49	4.2026	3.9686	3.7443	-1.65	1.59		
122	50	4.0588	3.8287	3.6084	-1.70	1.62		
124	51	3.9206	3.6943	3.4780	-1.74	1.66		
126	52	3.7878	3.5654	3.3531	-1.78	1.70		
127	53	3.6601	3.4416	3.2332	-1.82	1.74		
129	54	3.5374	3.3227	3.1183	-1.87	1.78		

Ambient, Defrosting and Pipe Sensor Tables

Temp.	°F	Temp.	°C	Max.(KΩ)	Normal(KΩ)	Min.(KΩ)	Tolerance
131	55	3.4195	3.2085	3.0079	-1.91	1.82	
133	56	3.3060	3.0989	2.9021	-1.95	1.85	
135	57	3.1969	2.9935	2.8005	-2.00	1.89	
136	58	3.0919	2.8922	2.7029	-2.04	1.93	
138	59	2.9909	2.7948	2.6092	-2.08	1.97	
140	60	2.8936	2.7012	2.5193	-2.13	2.01	
142	61	2.8000	2.6112	2.4328	-2.17	2.05	
144	62	2.7099	2.5246	2.3498	-2.22	2.09	
145	63	2.6232	2.4413	2.2700	-2.26	2.13	
147	64	2.5396	2.3611	2.1932	-2.31	2.17	
149	65	2.4591	2.2840	2.1195	-2.36	2.21	
151	66	2.3815	2.2098	2.0486	-2.40	2.25	
153	67	2.3068	2.1383	1.9803	-2.45	2.29	
154	68	2.2347	2.0695	1.9147	-2.49	2.34	
156	69	2.1652	2.0032	1.8516	-2.54	2.38	
158	70	2.0983	1.9393	1.7908	-2.59	2.42	
160	71	2.0337	1.8778	1.7324	-2.63	2.46	
162	72	1.9714	1.8186	1.6761	-2.68	2.50	
163	73	1.9113	1.7614	1.6219	-2.73	2.54	
165	74	1.8533	1.7064	1.5697	-2.78	2.58	
167	75	1.7974	1.6533	1.5194	-2.83	2.63	
169	76	1.7434	1.6021	1.4710	-2.88	2.67	
171	77	1.6913	1.5528	1.4243	-2.92	2.71	
172	78	1.6409	1.5051	1.3794	-2.97	2.75	
174	79	1.5923	1.4592	1.3360	-3.02	2.80	
176	80	1.5454	1.4149	1.2942	-3.07	2.84	
178	81	1.5000	1.3721	1.2540	-3.12	2.88	
180	82	1.4562	1.3308	1.2151	-3.17	2.93	
181	83	1.4139	1.2910	1.1776	-3.22	2.97	
183	84	1.3730	1.2525	1.1415	-3.27	3.01	
185	85	1.3335	1.2153	1.1066	-3.32	3.06	
187	86	1.2953	1.1794	1.0730	-3.38	3.10	
189	87	1.2583	1.1448	1.0405	-3.43	3.15	
190	88	1.2226	1.1113	1.0092	-3.48	3.19	
192	89	1.1880	1.0789	0.9789	-3.53	3.24	
194	90	1.1546	1.0476	0.9497	-3.58	3.28	
196	91	1.1223	1.0174	0.9215	-3.64	3.33	
198	92	1.0910	0.9882	0.8942	-3.69	3.37	
199	93	1.0607	0.9599	0.8679	-3.74	3.42	
201	94	1.0314	0.9326	0.8424	-3.80	3.46	
203	95	1.0030	0.9061	0.8179	-3.85	3.51	
205	96	0.9756	0.8806	0.7941	-3.90	3.55	
207	97	0.9490	0.8558	0.7711	-3.96	3.60	
208	98	0.9232	0.8319	0.7489	-4.01	3.64	
210	99	0.8983	0.8088	0.7275	-4.07	3.69	
212	100	0.8741	0.7863	0.7067	-4.12	3.74	
214	101	0.8507	0.7646	0.6867	-4.18	3.78	
216	102	0.8281	0.7436	0.6672	-4.23	3.83	

Ambient, Defrosting and Pipe Sensor Tables

Temp.	°F	Temp.	°C	Max.(KΩ)	Normal(KΩ)	Min.(KΩ)	Tolerance	(°C)
217	103	0.8061	0.7233	0.6484	-4.29	3.88		
219	104	0.7848	0.7036	0.6303	-4.34	3.92		
221	105	0.7641	0.6845	0.6127	-4.40	3.97		
223	106	0.7441	0.6661	0.5957	-4.46	4.02		
225	107	0.7247	0.6482	0.5792	-4.51	4.07		
226	108	0.7059	0.6308	0.5632	-4.57	4.12		
228	109	0.6877	0.6140	0.5478	-4.63	4.16		
230	110	0.6700	0.5977	0.5328	-4.69	4.21		
232	111	0.6528	0.5820	0.5183	-4.74	4.26		
234	112	0.6361	0.5667	0.5043	-4.80	4.31		
235	113	0.6200	0.5518	0.4907	-4.86	4.36		
237	114	0.6043	0.5374	0.4775	-4.92	4.41		
239	115	0.5891	0.5235	0.4648	-4.98	4.45		
241	116	0.5743	0.5100	0.4524	-5.04	4.50		
243	117	0.5600	0.4968	0.4404	-5.10	4.55		
244	118	0.5460	0.4841	0.4288	-5.16	4.60		
246	119	0.5325	0.4717	0.4175	-5.22	4.65		
248	120	0.5194	0.4597	0.4066	-5.28	4.70		

Discharge Sensor Tables

R176°=50KΩ±3%

B77°/176°=4450K±3%

Temp.(°F)	Temp.(°C)	Max.(KΩ)	Normal(KΩ)	Min.(KΩ)	Tolerance	
-22	-30	14646.0505	12061.7438	9924.4999	-2.96	2.45
-20.2	-29	13654.1707	11267.873	9290.2526	-2.95	2.44
-18.4	-28	12735.8378	10531.3695	8700.6388	-2.93	2.44
-16.6	-27	11885.1336	9847.724	8152.2338	-2.92	2.43
-14.8	-26	11096.6531	9212.8101	7641.8972	-2.91	2.42
-13	-25	10365.4565	8622.8491	7166.7474	-2.9	2.42
-11.2	-24	9687.027	8074.3787	6724.1389	-2.88	2.41
-9.4	-23	9057.2314	7564.2244	6311.6413	-2.87	2.41
-7.6	-22	8472.2852	7089.4741	5927.0206	-2.86	2.4
-5.8	-21	7928.7217	6647.4547	5568.2222	-2.84	2.39
-4	-20	7423.3626	6235.7109	5233.3554	-2.83	2.39
-2.2	-19	6953.293	5851.9864	4920.6791	-2.82	2.38
-0.4	-18	6515.8375	5494.2064	4628.5894	-2.8	2.37
1.4	-17	6108.5393	5160.4621	4355.6078	-2.79	2.37
3.2	-16	5729.1413	4848.9963	4100.3708	-2.77	2.36
5	-15	5375.5683	4558.1906	3861.6201	-2.76	2.35
6.8	-14	5045.9114	4286.5535	3638.1938	-2.75	2.34
8.6	-13	4738.4141	4032.7098	3429.0191	-2.73	2.34
10.4	-12	4451.4586	3795.391	3233.1039	-2.72	2.33
12.2	-11	4183.5548	3573.426	3049.5312	-2.7	2.32
14	-10	3933.3289	3365.7336	2877.4527	-2.69	2.31
15.8	-9	3699.5139	3171.3148	2716.0828	-2.67	2.3
17.6	-8	3480.9407	2989.246	2564.6945	-2.66	2.29
19.4	-7	3276.5302	2818.6731	2422.6139	-2.64	2.28
21.2	-6	3085.2854	2658.8058	2289.2164	-2.63	2.28
23	-5	2906.2851	2508.9126	2163.923	-2.61	2.27

Discharge Sensor Tables

Temp.(°F)	Temp.(°C)	Max.(KΩ)	Normal(KΩ)	Min.(KΩ)	Tolerance	
24.8	-4	2738.6777	2368.3158	2046.1961	-2.6	2.26
26.6	-3	2581.6752	2236.3876	1935.5371	-2.58	2.25
28.4	-2	2434.5487	2112.5459	1831.4826	-2.56	2.24
30.2	-1	2296.623	1996.2509	1733.6024	-2.55	2.23
32	0	2167.273	1887.0018	1641.4966	-2.53	2.22
33.8	1	2045.9191	1784.3336	1554.7931	-2.52	2.21
35.6	2	1932.0242	1687.8144	1473.146	-2.5	2.2
37.4	3	1825.0899	1597.0431	1396.2333	-2.48	2.19
39.2	4	1724.654	1511.6468	1323.7551	-2.47	2.17
41	5	1630.287	1431.2787	1255.4324	-2.45	2.16
42.8	6	1541.5904	1355.6163	1191.0048	-2.43	2.15
44.6	7	1458.1938	1284.3593	1130.2298	-2.41	2.14
46.4	8	1379.7528	1217.2282	1072.8813	-2.4	2.13
48.2	9	1305.9472	1153.9626	1018.7481	-2.38	2.12
50	10	1236.4792	1094.32	967.6334	-2.36	2.11
51.8	11	1171.0715	1038.0743	919.3533	-2.35	2.09
53.6	12	1109.4661	985.0146	873.7359	-2.33	2.08
55.4	13	1051.4226	934.944	830.621	-2.31	2.07
57.2	14	996.7169	887.6792	789.8583	-2.29	2.06
59	15	945.1404	843.0486	751.3077	-2.27	2.04
60.8	16	896.4981	800.8922	714.838	-2.26	2.03
62.6	17	850.6086	761.0603	680.3265	-2.24	2.02
64.4	18	807.3024	723.4134	647.658	-2.22	2
66.2	19	766.4212	687.8205	616.7252	-2.2	1.99
68	20	727.8172	654.1596	587.4271	-2.18	1.98
69.8	21	691.3524	622.3161	559.6694	-2.16	1.96
71.6	22	656.8979	592.1831	533.3634	-2.14	1.95
73.4	23	624.3328	563.6604	508.4261	-2.12	1.93
75.2	24	593.5446	536.654	484.7796	-2.1	1.92
77	25	564.4275	511.076	462.351	-2.09	1.9
78.8	26	536.9865	486.9352	441.1516	-2.07	1.89
80.6	27	511.0105	464.05	421.0258	-2.05	1.87
82.4	28	486.4151	442.3499	401.9146	-2.03	1.86
84.2	29	463.1208	421.7683	383.7626	-2.01	1.84
86	30	441.0535	402.243	366.5175	-1.99	1.83
87.8	31	420.1431	383.7151	350.1301	-1.97	1.81
89.6	32	400.3242	366.1295	334.5542	-1.95	1.8
91.4	33	381.535	349.4341	319.746	-1.93	1.78
93.2	34	363.7176	333.5801	305.6645	-1.9	1.76
95	35	346.8176	318.5216	292.2709	-1.88	1.75
96.8	36	330.7839	304.2151	279.5286	-1.86	1.73
98.6	37	315.5682	290.6199	267.4031	-1.84	1.71
100.4	38	301.1254	277.6976	255.862	-1.82	1.7
102.2	39	287.4128	265.4119	244.8745	-1.8	1.68
104	40	274.3905	253.7288	234.4118	-1.78	1.66
105.8	41	262.0206	242.6161	224.4465	-1.76	1.64
107.6	42	250.2676	232.0436	214.9529	-1.74	1.63
109.4	43	239.0983	221.9825	205.9065	-1.71	1.61
111.2	44	228.4809	212.406	197.2844	-1.69	1.59

Discharge Sensor Tables

Temp.(°F)	Temp.(°C)	Max.(KΩ)	Normal(KΩ)	Min.(KΩ)	Tolerance	
113	45	218.386	203.2887	189.0648	-1.67	1.57
114.8	46	208.7855	194.6066	181.2273	-1.65	1.55
116.6	47	199.6531	186.3369	173.7524	-1.63	1.54
118.4	48	190.9639	178.4584	166.6217	-1.6	1.52
120.2	49	182.6945	170.9508	159.8181	-1.58	1.5
122	50	174.8228	163.7951	153.3249	-1.56	1.48
123.8	51	167.328	156.9733	147.1268	-1.53	1.46
125.6	52	160.1904	150.4683	141.209	-1.51	1.44
127.4	53	153.3914	144.2641	135.5577	-1.49	1.42
129.2	54	146.9136	138.3454	130.1598	-1.47	1.4
131	55	140.7403	132.698	125.0027	-1.44	1.38
132.8	56	134.8559	127.3081	120.0746	-1.42	1.36
134.6	57	129.2457	122.163	115.3645	-1.4	1.34
136.4	58	123.8956	117.2504	110.8618	-1.37	1.32
138.2	59	118.7926	112.5589	106.5564	-1.35	1.3
140	60	113.9241	108.0776	102.4388	-1.32	1.28
141.8	61	109.2784	103.7961	98.5	-1.3	1.26
143.6	62	104.8443	99.7046	94.7315	-1.28	1.23
145.4	63	100.6112	95.7939	91.1253	-1.25	1.21
147.2	64	96.5692	92.0553	87.6735	-1.23	1.19
149	65	92.7088	88.4805	84.369	-1.2	1.17
150.8	66	89.0211	85.0614	81.2048	-1.18	1.15
152.6	67	85.4976	81.7908	78.1744	-1.15	1.12
154.4	68	82.1303	78.6615	75.2715	-1.13	1.1
156.2	69	78.9116	75.6668	72.4902	-1.1	1.08
158	70	75.8343	72.8004	69.8249	-1.08	1.06
159.8	71	72.8916	70.0561	67.2703	-1.05	1.03
161.6	72	70.077	67.4283	64.8213	-1.03	1.01
163.4	73	67.3844	64.9115	62.4731	-1	0.99
165.2	74	64.808	62.5006	60.2211	-0.98	0.96
167	75	62.3423	60.1906	58.0609	-0.95	0.94
168.8	76	59.9821	57.977	55.9885	-0.92	0.92
170.6	77	57.7223	55.8552	53.9998	-0.9	0.89
172.4	78	55.5583	53.821	52.0912	-0.87	0.87
174.2	79	53.4856	51.8706	50.2591	-0.85	0.84
176	80	51.5	50	48.5	-0.85	0.84
177.8	81	49.7063	48.2057	46.7083	-0.85	0.85
179.6	82	47.9835	46.4842	44.9911	-0.89	0.89
181.4	83	46.3286	44.8323	43.3452	-0.93	0.92
183.2	84	44.7385	43.2468	41.7672	-0.96	0.95
185	85	43.2105	41.7248	40.254	-1	0.99
186.8	86	41.7386	40.2604	38.7996	-1.03	1.02
188.6	87	40.3241	38.8545	37.4048	-1.07	1.06
190.4	88	38.9643	37.5045	36.0668	-1.11	1.09
192.2	89	37.6569	36.2078	34.7831	-1.14	1.13
194	90	36.3996	34.9622	33.5513	-1.18	1.16
195.8	91	35.1903	33.7653	32.3689	-1.22	1.19
197.6	92	34.0269	32.6151	31.2338	-1.26	1.23
199.4	93	32.9075	31.5096	30.1438	-1.3	1.27

Discharge Sensor Tables

Temp.(°F)	Temp.(°C)	Max.(KΩ)	Normal(KΩ)	Min.(KΩ)	Tolerance	
201.2	94	31.8302	30.4467	29.097	-1.33	1.3
203	95	30.7933	29.4246	28.0915	-1.37	1.34
204.8	96	29.795	28.4417	27.1254	-1.41	1.37
206.6	97	28.8337	27.4961	26.197	-1.45	1.41
208.4	98	27.9078	26.5864	25.3048	-1.49	1.44
210.2	99	27.016	25.711	24.447	-1.53	1.48
212	100	26.1569	24.8685	23.6222	-1.57	1.52
213.8	101	25.329	24.0574	22.8291	-1.61	1.55
215.6	102	24.5311	23.2765	22.0662	-1.65	1.59
217.4	103	23.762	22.5245	21.3323	-1.69	1.63
219.2	104	23.0205	21.8002	20.6261	-1.73	1.66
221	105	22.3055	21.1025	19.9465	-1.77	1.7
222.8	106	21.6159	20.4303	19.2924	-1.81	1.74
224.6	107	20.9508	19.7825	18.6626	-1.85	1.77
226.4	108	20.3091	19.1582	18.0563	-1.89	1.81
228.2	109	19.6899	18.5564	17.4723	-1.93	1.85
230	110	19.0924	17.9761	16.9098	-1.98	1.89
231.8	111	18.5157	17.4166	16.368	-2.02	1.93
233.6	112	17.959	16.8769	15.8458	-2.06	1.96
235.4	113	17.4214	16.3564	15.3427	-2.1	2
237.2	114	16.9023	15.8542	14.8577	-2.15	2.04
239	115	16.401	15.3696	14.3902	-2.19	2.08
240.8	116	15.9167	14.902	13.9394	-2.23	2.12
242.6	117	15.4489	14.4506	13.5047	-2.27	2.16
244.4	118	14.9968	14.0149	13.0855	-2.32	2.19
246.2	119	14.5599	13.5942	12.6811	-2.36	2.23
248	120	14.1376	13.1879	12.2909	-2.41	2.27
249.8	121	13.7294	12.7955	11.9144	-2.45	2.31
251.6	122	13.3347	12.4165	11.551	-2.5	2.35
253.4	123	12.9531	12.0503	11.2003	-2.54	2.39
255.2	124	12.584	11.6965	10.8617	-2.58	2.43
257	125	12.227	11.3545	10.5348	-2.63	2.47
258.8	126	11.8817	11.024	10.2191	-2.68	2.51
260.6	127	11.5475	10.7046	9.9142	-2.72	2.55
262.4	128	11.2242	10.3957	9.6197	-2.77	2.59
264.2	129	10.9112	10.097	9.3352	-2.81	2.63
266	130	10.6084	9.8082	9.0602	-2.86	2.67
267.8	131	10.3151	9.5288	8.7945	-2.91	2.71
269.6	132	10.0312	9.2586	8.5378	-2.95	2.75
271.4	133	9.7563	8.9971	8.2895	-3	2.8
273.2	134	9.4901	8.7441	8.0495	-3.05	2.84
275	135	9.2322	8.4993	7.8175	-3.09	2.88
276.8	136	8.9824	8.2623	7.5931	-3.14	2.92
278.6	137	8.7404	8.0329	7.376	-3.19	2.96
280.4	138	8.5059	7.8108	7.166	-3.24	3
282.2	139	8.2787	7.5958	6.9629	-3.29	3.04
284	140	8.0584	7.3875	6.7664	-3.33	3.09

Ductless Split Heat Pump

New Models :

Indoor
 AW09TE2VHA
 AW12TE2VHA
 ASYW09CRDWA
 ASYW12CRDWA

Outdoor
 1U09TE2VHA
 1U12TE2VHA
 ASH109CRDWA
 ASH112CRDWA

Service Manual

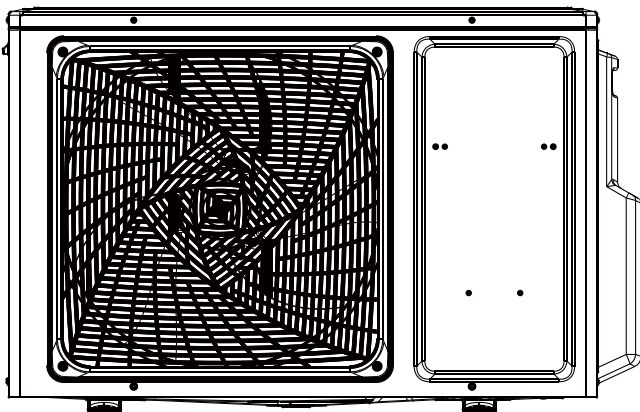
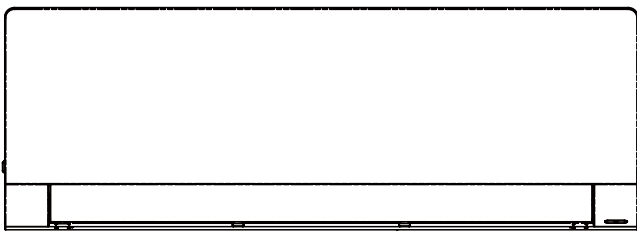

Design may vary by model number.

- Please read this manual before installing this product.
- **Keep this service manual for future reference.**

Table of Contents

Outdoor Unit Controls and Components	83
Indoor Unit Controls and Components	89
Sequence of Operation	95
System Specifications	103
Error Codes and Troubleshooting	104
Reference Information	133

[This page intentionally left blank.]

Table of Contents

Outdoor Unit Introduction 84
Outdoor Component Identification 84
Outdoor Main Control Board 85
Terminal Block 86
Reactor 86
Compressor 86
Outdoor Fan Motor 86
Discharge Temperature Sensor 87
Defrost Temperature Sensor 87
Outdoor Ambient Temperature Sensor 87
Suction Line Temperature Sensor 87
4-Way Valve 88
Electronic Expansion Valve 88
Accumulator 88
Strainers 88

Outdoor Unit Introduction

The outdoor unit has two circuit boards, an Inverter Power Module (IPM) that drives the compressor and main control board (PCB) that manages system functions and inverter calculations. Sensors monitor key temperatures throughout the system to manage operational decisions.

Outdoor Component Identification

- 1 4-Way Valve
- 2 Accumulator
- 3 Compressor
- 4 Defrost Temperature Sensor
- 5 Discharge Temperature Sensor
- 6 Electronic Expansion Valve
- 7 Refrigerant Strainers
- 8 Ambient Temperature Sensor
- 9 Fan Motor
- 10 Power Factor Reactor
- 11 Suction Line Temperature Sensor
- 12 Terminal Block
- 13 Main Control Board (PCB)
- 14 Module Control Board (IPM)
- 15 Fan Blade

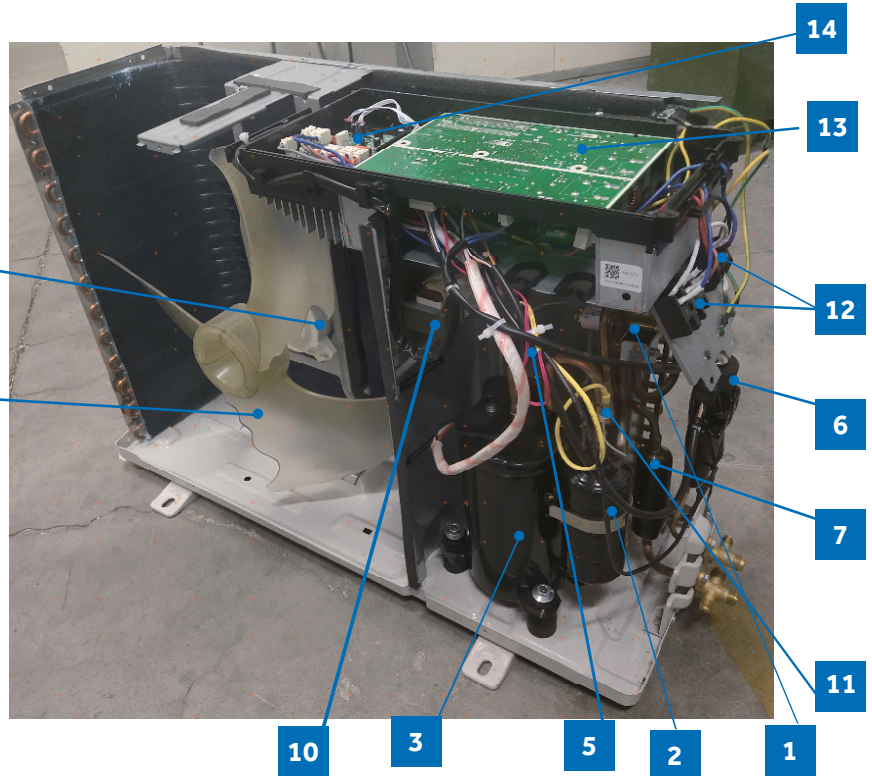

PCB

PCB (1) (Outdoor Control PCB)

- 1 CN1 and CN2 - 230 VAC power from terminal block connections 1(N) and 2(L), CN6-connector for COM-N
- 2 CN5 - Connector for GND
- 3 CN4 -Communication connection between the indoor board and the outdoor board
- 4 CN8 and CN9 - 230 VAC power to the IPM connections CN8 (or CN1) and CN9(or CN2)
- 5 CN21 - Connector for fan motor
- 6 CN10 - Connector for four way valve coil
- 7 CN18,CN20,CN31 - connections for temperature sensors
- 8 CN26, CN24 - 310 VDC power from the IPM connections CN1 (or CN8) and CN5 (or CN9)
- 9 CN22-Connector for DC POWER 15V and 5V to the IPM
- 10 CN23 -5VDC and 15VDC pulsing communication connection between the PCB and the IPM
- 11 CN16-Connector for the electronic expansion valve
- 12 CN48 -Connector for the base pan heater
- 13 CN49-Connector for COMP heater
- 14 CN38- Connector for diagnostic port
- 15 RV1, RV2, RV3 Varistor

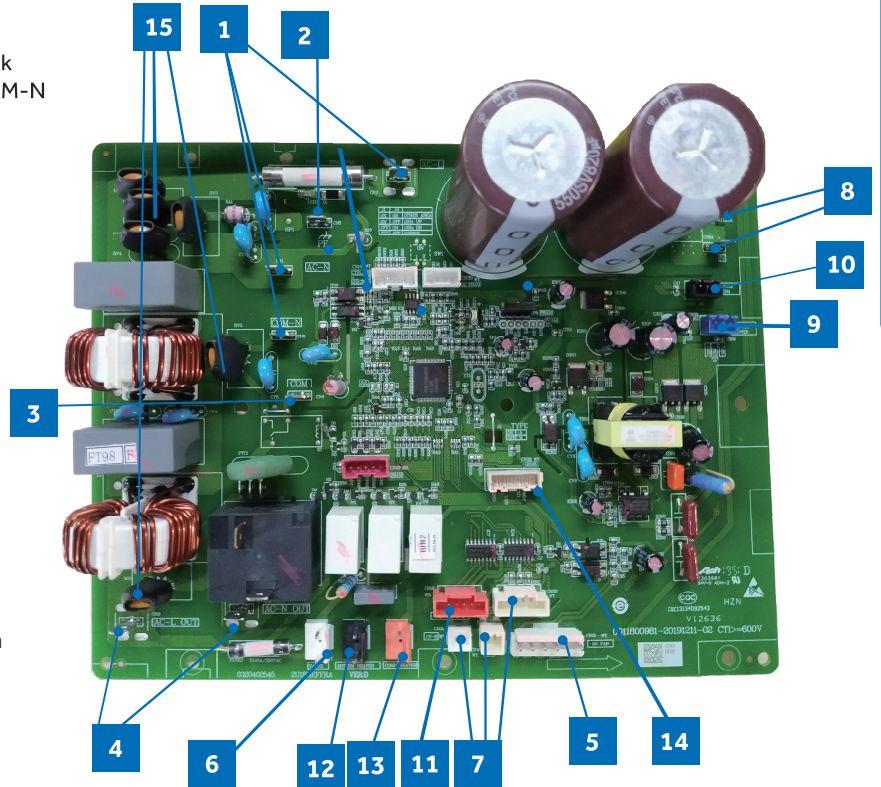

PCB (2) (IPM for 09K)

- 16 CN10 - Connector for the DC power 5V and 15V form the control PCB
- 17 CN11-Pulsing communication connection between the IPM and the PCB
- 18 CN1,CN5-310 VDC signal to the PCB connections CN26 and CN24
- 19 LI(CN7),LO(CN6)-Connector for reactor
- 20 CN8, CN9 - 230 VAC signal from the PCB
- 21 CN2, CN3, CN4- Compressor U, V, and W connections

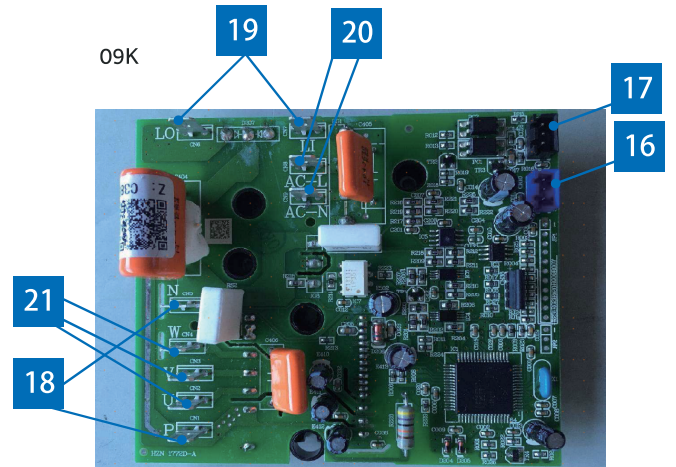

PCB (3) (IPM for 12-18K)

- 22 CN10-5 VDC and 15 VDC power signal from PCB connection CN22
- 23 CN11 - Connector for communicate between the control board and the module board
- 24 CN8, CN9 - 310 VDC power to PCB connections CN26 and CN24
- 25 LI (CN3), LO (CN4) - Connector for reactor
- 26 CN1, CN2 - 230 VAC power from PCB connections CN8 and CN9
- 27 CN5, CN6, CN7-Compressor U, V, and W connections

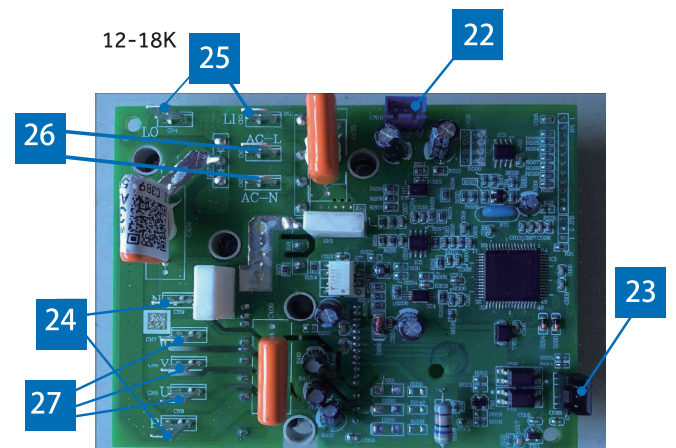

Terminal Block

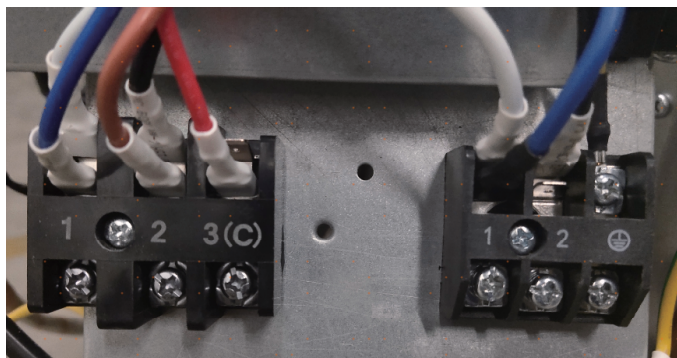

The outdoor unit is powered by 208/230 volt single phase electricity connected at the terminal block.

Terminals 1 and 2 connect this voltage to the system. The number 3 terminal is communication that connects wiring between the indoor and outdoor units. A ground terminal connects the outdoor unit to the line voltage power source.

Condensate safety switches should break the wire on terminal 2.

The indoor unit is also powered by the same electrical supply as the outdoor unit. #14 stranded copper wire is connected to the wiring terminal block at the outdoor unit and is run to the same terminals on the indoor terminal block.

When installing the field supplied wiring, make certain the wire gauge is correct. There should not be any electrical wiring splices between the indoor unit and outdoor unit wire connection 3. This wire is used to carry communication data between the indoor and outdoor units. A wiring splice where wires are twisted in a wire nut may cause deformation of the communication signal. If communication is lost between the indoor and outdoor units, an ERROR CODE E7 will occur. (See Page 36.)

Power Factor Reactor

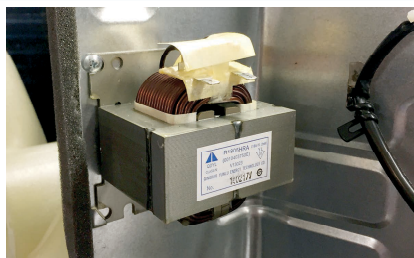

The Reactor is a power filter. It is unlikely to ever have an electrical failure of this component.

The Reactor of 09K is electrically connected to the IPM on terminal connections CN6 and CN7.

The Reactor of 12K&18K is electrically connected to the IPM on terminal connections CN3 and CN4.

Compressor



The compressor is a three phase DC inverter driven rotary type, capable of variable speed operation. The compressor operating frequency will be determined by the temperature difference between set point and room temperature.

The compressor of 09K is electrically connected to the IPM on terminal connections CN2, CN3 and CN4.

The compressor of 12K&18K is electrically connected to the IPM on terminal connections CN5, CN6 and CN7.

Protection of the compressor will be provided by the discharge temperature sensor, the suction line temperature sensor, and the overcurrent protection parameter in the PCB.

Fan Motor



The fan motor is a variable speed motor. The required speed is calculated by the PCB. The motor is electrically connected to the PCB via PLUG CN-21.

In COOL MODE, the motor will slow down as outdoor air temperature falls. In HEAT MODE, the motor will increase speed as the outdoor air temperature falls.

Discharge Temperature Sensor



The Discharge Temperature Sensor is a negative coefficient thermistor that senses the temperature of the compressor hot gas. The PCB monitors the temperature of the compressor hot gas and will make inverter speed changes in response to input from this device.

This sensor connects to the Main Control Board at PLUG CN-20.

Defrost Temperature Sensor A

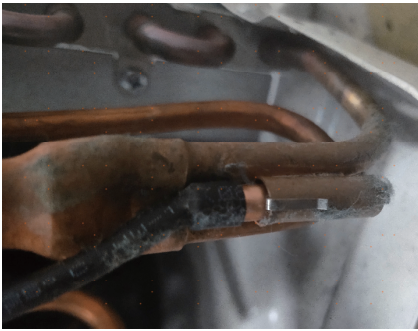

The Defrost Temperature Sensor A is a negative coefficient thermistor that will change resistance in response to outdoor coil temperature changes. The PCB monitors the temperature of the outdoor coil to determine when the system should perform a defrost cycle. The sensor also monitors coil temperature during defrost cycles to determine termination conditions.

This sensor connects to the Main Control Board at PLUG CN-20.

Ambient Temperature Sensor



The Ambient Temperature Sensor is a negative coefficient thermistor that will change resistance in response to outdoor air temperature changes. The PCB monitors the temperature of the outdoor air to determine fan speed requirements and inverter speed. The sensor also plays a role in calculation of required defrost conditions.

This sensor connects to the Main Control Board at PLUG CN-20.

Suction Line Temperature Sensor

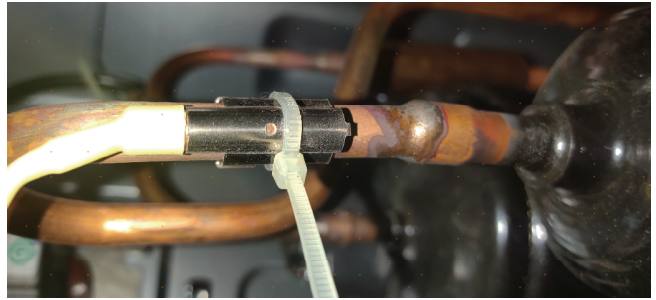

The Suction Line Temperature Sensor is a negative coefficient thermistor that senses the temperature of the suction line. The PCB monitors the temperature of the suction line and the EEV operation to maintain an acceptable superheat.

This sensor connects to the Main Control Board at PLUG CN-18.

4-Way Valve



The 4-Way Valve redirects the flow of refrigerant in the piping circuit to allow the system to reverse the functions of the indoor and outdoor coils. When de-energized in COOL MODE, the valve will direct the refrigerant hot gas to the outdoor coil. When energized in HEAT MODE, the valve will direct the hot gas to the indoor coil.

The valve flow direction capability is controlled by an electrical solenoid. When energized with 230 VAC, the solenoid will magnetically move an internal slide within the 4-Way Valve to change the direction of refrigerant flow.

The 4-Way Valve is electrically connected to the Main Control Board at PLUG CN-10.

Electronic Expansion Valve



The metering device is an electronic expansion valve. The valve consists of an electrical operator and a valve body with internal variable size orifice. When operating, the PCB will send pulses of voltage to the electrical operator. The operator will then magnetically move the position of the metering orifice pin to vary refrigerant flow.

The metering device position is determined by input from a Suction Line Temperature Sensor. The EEV will change the internal orifice size to maintain an acceptable level of superheat.

During COOL MODE the valve meters low pressure refrigerant to the indoor coil. During HEAT MODE the valve meters low pressure refrigerant to the outdoor coil.

The electrical expansion valve is electrically connected to the Main Control Board at PLUG CN-16.

Accumulator



The Accumulator is located in the suction line circuit at the entrance to the compressor. The accumulator helps prevent liquid refrigerant from entering the compressor during run operation.

Refrigerant Strainers



The system has debris-catching strainers that protect internal system components from contaminants in the refrigerant. The strainer is a permanent part that is not typically replaced.

Table of Contents

Indoor Unit Introduction90
Indoor Component Identification90
Indoor Control Board.....91
Terminal Block.....92
Display92
Ambient Temperature Sensor92
Piping Temperature Sensor92
Louver Motor93
Fan Motor93
Emergency Button93
DIP Switch and DIP Switch Settings.....94

Indoor Unit Introduction

The indoor unit is mounted high on the wall to provide comfort and air movement within the conditioned space. Features of the system include: Variable speed blower operation that speeds up and slows down with changes in demand, moving louvers to direct air, indoor air temperature sensing, evaporator coil temperature sensing, a status display, evaporator coil with metering device located in outdoor unit, and an emergency operation button.

Indoor Component Identification

- | | | | |
|---|----------------------------|---|---------------------------|
| 1 | Ambient Temperature Sensor | 6 | Piping Temperature Sensor |
| 2 | Display | 7 | Terminal Block |
| 3 | Fan Motor | 8 | Emergency Button |
| 4 | Louver Motor | | |
| 5 | PCB | | |

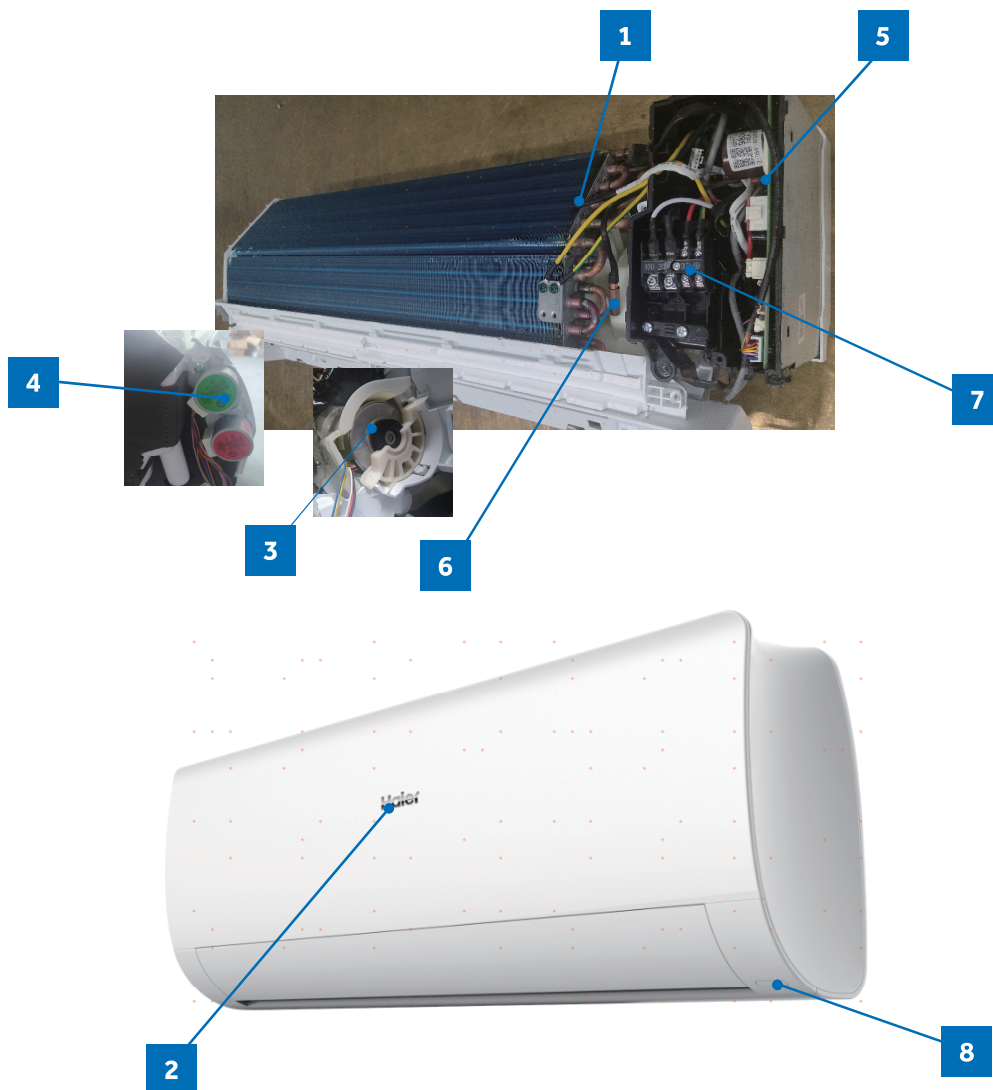

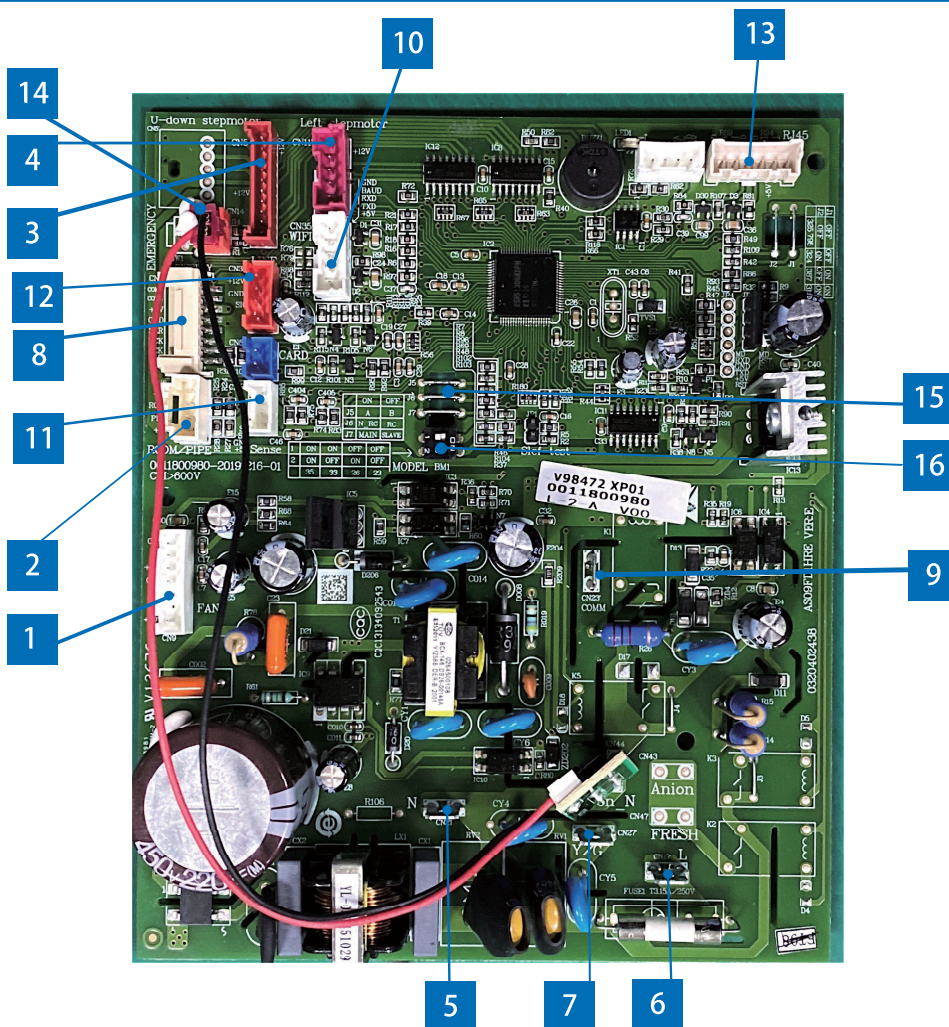

- | | |
|--|---|
| 1 CN9-Connector for fan motor | 10 CN35-Connector for WiFi module |
| 2 CN6-Connector for coil temperature sensor and room temperature sensor | 11 CN56-Connector for occupancy sensor |
| 3 CN5-Connector for UP/DOWN STEP motor | 12 CN34-Connector for wired controller interface |
| 4 CN11-Connector for LEFT/RIGHT STEP motor | 13 CN38-Connector for diagnostic port |
| 5 CN21-Connector for power N | 14 CN14-Connector for forced operation ON / OFF switch |
| 6 CN17-Connector for power L | 15 J5-Select remote code A or B
J6-Select room card able or disable |
| 7 CN27-Connector for GND | 16 BM1 1-2 Select 23, 26, 33, or 35 |
| 8 CN7-Connector for display board | |
| 9 CN23-Communication connection between the PCB and the outdoor unit | |

Terminal Block

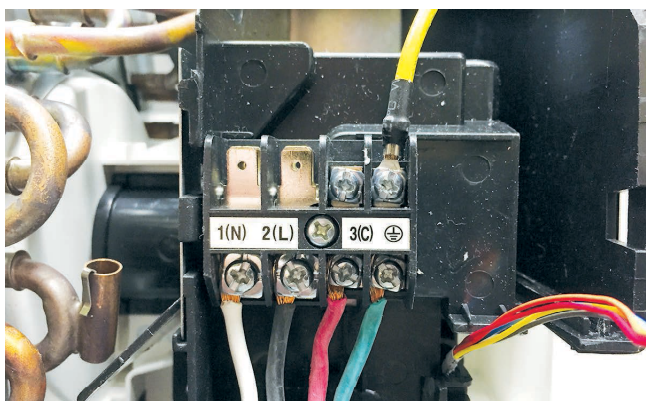

The unit terminal block receives electrical power from the outdoor unit. There are 4 connections for electrical wires. Terminals 1 and 2 are connected to terminals 1 and 2 of the outdoor unit. This wiring supplies power to the indoor unit.

Terminal 3 is a communication wire. The indoor unit sends indoor air temperature, coil temperature and temperature setpoint information to the outdoor unit on this wire. If a splice or break in this wire is present, the indoor unit will not be able to communicate with the outdoor unit. The ERROR CODE will be an E7.

Display

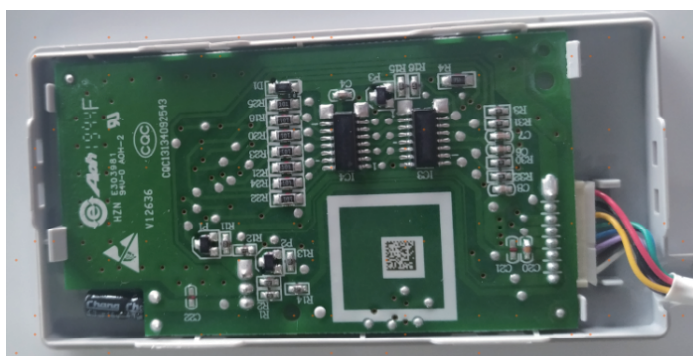

The indoor display has an infrared communication circuit that receives operating commands from the remote control. This display will indicate operating modes, error codes, indoor air temperature, timer status, and power status.

Ambient Temperature Sensor



The Ambient (room) Temperature Sensor is a negative coefficient thermistor that will decrease in resistance with increases in room air temperature. The sensor is located on a clip mounted in the return air stream.

The sensor connects to the control board at Plug CN-6.

Piping Temperature Sensor

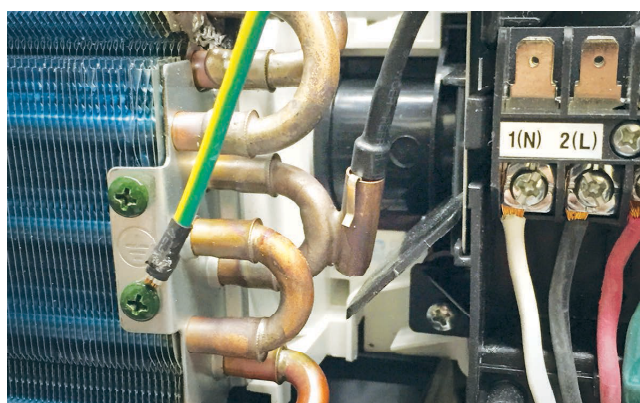

The Piping Temperature Sensor is a negative coefficient thermistor that will decrease in resistance with increases in coil temperature. The sensor is located in a socket soldered to the surface of the indoor coil.

This sensor will monitor the temperature of the indoor coil in both cooling and heating modes of operation. Should abnormally cold or hot coil temperature be detected by this sensor, the system will take steps to correct the condition or report an ERROR CODE.

The sensor connects to the control board at Plug CN-6.

Stepper Motor



The STEPPER MOTOR moves the louver up and down, or right and left, depending upon selections made at the remote control.

These motors are connected at CN5 and CN11.

Emergency Button



If the remote control is non-functional, the Emergency Button can be used. 73 -78 degrees will be maintained, until commands are received via the remote control.

Fan Motor



The Fan Motor is a variable speed motor. The air volume will vary with the speed of the compressor, or it can be set at the remote control to maintain a single speed.

The Fan Motor is connected to the indoor control board via PLUG CN-9.

DIP Switch

DIP Switch Settings

The PCB has a set of DIP switches that must be set when replacing the PCB.

The replacement PCB is shipped with all switches set to the OFF position.

Switch settings:

J5 Selects remote code A or B. Normally set to connection state for code A operation.

If two indoor units are used in the same area and the user wishes to control them separately, switch J5 of the second unit is set to be cut off for code B operation. The wireless remote for the second unit is also set to code B.

J6 Selects room card able or disable. Normally set to connection state. Set to the disconnected state when used in conjunction with a room card interface utilized in hotel rooms.

SW-1 and SW-2 Selects EEPROM codes 23, 26, 33 and 35. Set to identify the tonnage of the unit.

Settings:

9K	(23)	SW-1	OFF	SW-2	OFF
12K	(26)	SW-1	OFF	SW-2	ON

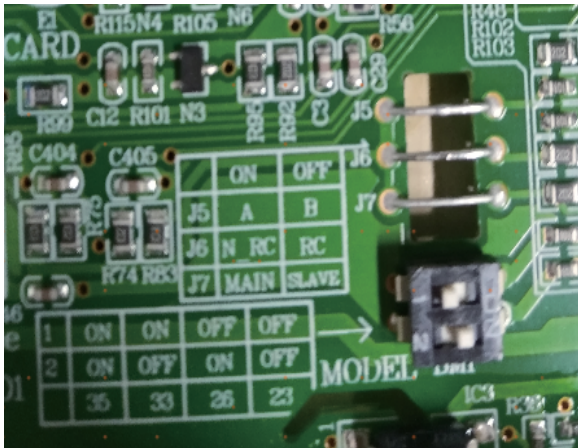

Table of Contents

System Power	96
Cool Mode	96
<i>Overview.....</i>	96
<i>Indoor Unit.....</i>	96
<i>Temperature Sensors.....</i>	96
<i>Communication.....</i>	96
<i>Outdoor Unit.....</i>	96
<i>Temperature Sensors.....</i>	97
<i>Call to Terminate Cooling</i>	97
<i>Freeze Protection Function.....</i>	97
Heat Mode.....	97
<i>Overview.....</i>	97
<i>Cold Air Proof Operation.....</i>	97
<i>Defrost.....</i>	98
<i>Automatic Heating Temperature Compensation.....</i>	98
<i>Indoor Unit.....</i>	98
<i>Temperature Sensors.....</i>	98
<i>Communication.....</i>	98
<i>Outdoor Unit.....</i>	98
<i>Temperature Sensors.....</i>	98
<i>Call to Terminate Heating</i>	99
Auto Mode.....	99
Dry Mode	99
<i>Overview.....</i>	99
<i>Indoor Unit.....</i>	99
<i>Temperature Sensors.....</i>	99
<i>Communication.....</i>	99
<i>Outdoor Unit.....</i>	99
<i>Temperature Sensors.....</i>	100
Defrost Operation.....	100
Protection Functions	100
<i>High Temperature Protection.....</i>	100
<i>Overheating Protection for Indoor Unit.....</i>	100
<i>Compressor Overcurrent Protection.....</i>	101
<i>Anti-freeze Protection of the Coil.....</i>	101
<i>Base Pan Heater</i>	101
Special Functions	102
<i>Auto Restart</i>	102
<i>Timed Defrost.....</i>	102
<i>Demand Defrost</i>	102
<i>Indoor Temperature Display</i>	102
<i>Temperature Compensation.....</i>	102
<i>RJ45.....</i>	102

System Power

The 230 Volt AC power for the system connects to terminals 1(N), 2(L), and ground of the outdoor unit terminal block. This terminal block also has terminals to connect power to the indoor unit.

The voltage readings between terminals 1(N) and ground, and terminals 2(L) and ground should be 120 VAC. The voltage reading between terminals 1(N) and 2(L) should be 230 VAC.

One additional connection on the terminal block (3) is for the communication wire between the indoor and outdoor units.

NOTE: Mis-wiring of these connections may cause improper operation or damage to system components.

Cool Mode

Overview

The temperature control range in cooling mode is 60°F - 86°F. The temperature set by the remote control and the indoor unit ambient temperature sensor will determine if a call for cooling is needed. If a call for cooling is justified, the call is communicated from the indoor unit to the outdoor unit. The indoor unit louver will open using a stepper motor, and the indoor fan will operate at the speed last set. The outdoor unit will determine the position of the EEV and speed frequency of the compressor. There can be a delay of up to 3 minutes before the outdoor unit fan and compressor start.

The speed of the indoor fan can be controlled manually by the user or automatically by the system. The speed can be changed between LOW, MEDIUM, and HIGH.

The predetermined conditions for automatic control are as follows:

(Tr = room temperature Ts = set temperature)

High Speed: $Tr \geq Ts + 5.4^{\circ}\text{F}$

Medium Speed: $Ts + 1.8^{\circ}\text{F} \leq Tr < Ts + 5.4^{\circ}\text{F}$

Low Speed: $Tr \leq Ts + 1.8^{\circ}\text{F}$ or when the sensor is off.

There will be a 2 second delay when manually controlling the speed.

The outdoor unit temperature sensors: outdoor ambient, defrost, suction line, and compressor discharge, used in conjunction with the indoor temperature sensors, indoor ambient and coil, provide information to the outdoor control board to monitor the system and regulate the frequency of the compressor, the EEV, and outdoor fan speed, to achieve the desired room temperature.

When the call for cooling has been satisfied, the compressor will turn off, followed by the outdoor fan. The indoor unit fan will continue to run.

If the system detects a malfunction, it may shut down or show an error code. This code will be shown on the indoor display board or a flashing LED will appear on the outdoor PCB.

Indoor Unit

To enter the cool mode, point the infrared remote control at the indoor unit and press the power button, then press the COOL mode button if not already set to cool mode.

The signals received by the infrared receiver are relayed to the main board of the indoor unit to turn the system on and set it to cool mode.

The indoor unit PCB will illuminate the display, indicating the set temperature and current status of the unit.

The PCB will signal the stepper motor to open the louver to either a stationary position, or one of several oscillating modes.

As the louver opens, the indoor unit main board will power up the indoor fan motor, operating the fan at the speed last set. The indoor fan motor has a feedback circuit which provides the indoor unit main board with information for controlling the speed of the fan motor.

Temperature Sensors

The indoor unit has two sensors that provide temperature information to the main board. The sensors: an indoor ambient temperature sensor, and pipe temperature sensor, are used for controlling the system during cool mode. The resistance values of the sensors will vary with temperature. The resistance to temperature values can be found using a temperature / resistance chart specific to the sensor being checked.

Communication

The indoor and outdoor unit main boards communicate via a digital signal on the wire connected to terminal 3 of each unit. A splice or break in this wire will cause a communication error.

When a command is received from the remote control, the indoor unit main board communicates with the outdoor unit main board to perform the requested function.

Outdoor Unit

Upon a request for cooling, the outdoor unit main board applies power to the outdoor fan motor and compressor. Depending on system cycling, there may be up to a 3 minute wait period before the compressor and outdoor fan start.

If the room temperature is less than the set temperature, yet higher than 2°F below the set temperature, the system will adjust the speed of the compressor automatically.

The outdoor unit main board also controls the position of the EEV (Electronic Expansion Valve) to regulate the flow of refrigerant to the indoor unit evaporator coil.

Temperature Sensors

Four temperature sensors located in the outdoor unit provide temperature information to the outdoor unit main board for control of the system during cool mode.

The outdoor ambient temperature sensor provides the temperature of the air drawn into the condenser coil.

The defrost temperature sensor provides the temperature sensed at the output of the condenser coil.

The suction line temperature sensor provides the temperature sensed at the incoming suction line pipe.

The compressor discharge sensor provides the temperature sensed at the discharge pipe of the compressor.

Call to Terminate Cooling

The system will terminate cooling when the indoor ambient temperature sensor is equal to or lower than 2°F of the room set temperature. The indoor control board will communicate to the outdoor control board to de-energize the compressor. The outdoor fan will run for 60 seconds before stopping.

The indoor fan motor and louver will continue operating after cooling has been terminated.

To stop cool mode, press the power button to turn the system off, or change to another mode.

Freeze Protection Function

When the compressor operates continuously for 10 seconds and the temperature of the indoor coil has been below 32°F for 10 seconds, the compressor will stop. The indoor unit fan will continue to operate. When the temperature of the indoor coil rises to 45°F for more than 3 minutes the compressor will restart and the system will continue functioning.

Heat Mode

Overview

The temperature control range in heating mode is 60°F - 86°F. The temperature set by the remote control and the indoor unit ambient temperature sensor will determine if a call for heat is needed. If a call for heat is justified, a temperature compensation adjustment is automatically added to the

operating parameter and the call is communicated from the indoor unit to the outdoor unit.

The indoor unit louver will open using a stepper motor. The indoor fan will not operate at this time.

The outdoor unit will shift the 4-way valve to the heat mode position and determine the position of the EEV and speed (frequency) of the compressor. There can be a delay of up to 3 minutes before the outdoor unit fan and compressor start.

(Tr = room temperature Ts = set temperature)

If $Tr \leq Ts$, the outdoor unit will operate and the indoor fan operates in cold air prevention function

If $Tr > Ts$, the outdoor unit turns off and the indoor fan operates at heat residue sending mode.

If $Tr < Ts$, the outdoor unit will restart and the indoor fan operates in cold air proof mode.

The speed of the indoor fan can be controlled manually by the user or automatically by the system. The speed can be changed between HIGH, MEDIUM, and LOW. The predetermined conditions for automatic control are as follows:

High Speed: $Tr < Ts$

Medium Speed: $Ts \leq Tr \leq Ts + 4^\circ\text{F}$

Low Speed: $Tr > Ts + 4^\circ\text{F}$

When the indoor fan is running in automatic mode when the speed switches from high to low, the indoor fan will maintain high speed for a period of 3 minutes before switching to low speed.

Cold Air Proof Operation

At initial start of heat mode, indoor blower will not be turned on immediately until indoor coil temperature senses a minimum temperature. This period usually takes 30 seconds to 3 minutes depending on the outdoor temperature.

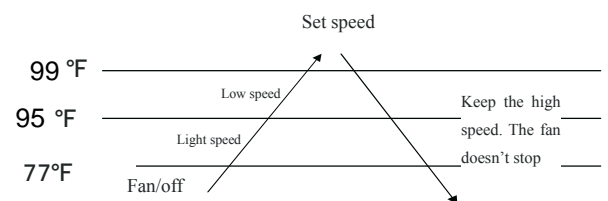

4 minutes after the indoor fan starts, the light or low speed will switch to the set speed.

Residual heat sending: the indoor fan will operate on low speed until the coil temperature reaches 77 degrees.

The outdoor unit temperature sensors: outdoor ambient, defrost, suction line, and compressor discharge, used in conjunction with the indoor coil and room temperature

sensors, provide information to the outdoor control board to monitor the system and regulate the speed of the compressor, the EEV and outdoor fan speed to achieve the desired room temperature.

When heating has been satisfied, the compressor will turn off first, followed by the outdoor fan. The 4-way valve will de-energize 2 minutes after compressor stops.

The indoor unit fan will continue to run at minimum speed until indoor coil temperature reaches a minimum temperature, when it will turn off.

If the system detects a malfunction, it may shut down or show an error code on the indoor unit display board and/or outdoor unit main board LED.

Defrost

When the system initiates a call for defrost, the indoor fan motor stops. The indoor unit display will not change. Any indoor unit malfunctions will be ignored at this time. The system will cycle through the defrost operation. Any indoor unit malfunctions will be ignored until the compressor restarts and has been operating for 30 seconds. At the conclusion of the defrost cycle, the indoor fan will enter the cold air proof operation. Heat mode resumes.

Automatic Heating Temperature Compensation

When the system enters heating mode, a temperature compensation adjustment is added to the operating parameter. This adjustment is canceled when exiting heat mode.

Indoor Unit

To enter the heat mode, point the infrared remote controller at the indoor unit and press the power button, then press the HEAT mode button if not already set to heat mode.

The signals received by the infrared receiver are relayed to the main board of the indoor unit to turn the system on and set it to heat mode.

The indoor unit PCB will activate the display of the indoor unit, illuminating the display and indicating the set temperature and current status of the unit.

The indoor unit PCB will signal the stepper motor to open the louver to a stationary position.

The PCB will power up the indoor fan motor after the outdoor unit has started and heating of the indoor coil has taken place (see cold air proof operation). The motor has a feedback circuit which provides information for controlling the speed of the fan motor.

Temperature Sensors

The indoor unit has two sensors that provide temperature information to the indoor unit main board. The sensors: a room temperature sensor, and pipe temperature sensor, are used for controlling the system during heat mode.

The resistance values of the sensors will vary with temperature. The resistance to temperature values can be found using a temperature /resistance chart specific to the sensor being checked.

Communication

The indoor and outdoor unit main boards communicate via a digital signal on the wire connected to terminal 3 of each unit. A splice or break in this wire will cause a communication error.

When a command is received from the remote control, the indoor unit main board communicates with the outdoor unit to perform the requested function.

Outdoor Unit

Upon a request for heat, the outdoor unit PCB applies power to the 4-way valve, outdoor fan motor, and compressor. Depending on system cycling, there may be up to a 3 minute wait period before the compressor and outdoor fan start.

If the room temperature is above the set temperature, yet lower than 2°F above the set temperature, the system will adjust the running frequency of the compressor automatically.

The outdoor unit main board also controls the position of the EEV (Electronic Expansion Valve) to regulate the flow of refrigerant to the outdoor unit evaporator coil.

Temperature Sensors

Four temperature sensors located in the outdoor unit provide temperature information to the PCB for control of the system during heat mode.

The ambient temperature sensor provides the temperature of the air drawn into the condenser coil.

The defrost temperature sensor provides the temperature sensed at the output of the condenser coil.

The suction line temperature sensor provides the temperature sensed at the incoming suction line pipe.

The compressor discharge sensor provides the temperature sensed at the discharge pipe of the compressor.

Call to Terminate Heating

The system will call to terminate heating when the indoor temperature is equal to or higher than 2°F above the room set temperature. The indoor control board will communicate to the outdoor control board to de-energize the compressor. The outdoor fan will run for 60 seconds before stopping. The 4-way valve will de-energize 2 minutes after the compressor stops.

To stop heat mode, press the power button to turn the system off, or change to another mode.

Auto Mode

With the system turned on, press the AUTO button on the remote control. The system will change to the auto mode of operation.

As the room is cooled or heated, the system will automatically switch between cool mode, fan mode, and heat mode. There is a minimum 15 minute operating time between mode changes.

Dry Mode

Overview

The temperature control range is 60°F - 86°F. This mode is used for dehumidification.

(Tr = room temperature Ts = set temperature)

When $Tr > Ts + 4^{\circ}\text{F}$, the compressor will turn on and the indoor fan will operate at the set speed.

When $Ts \leq Tr \leq Ts + 4^{\circ}\text{F}$, the compressor will operate at the high dry frequency for 10 minutes, then at the low dry mode for 6 minutes. The indoor fan will operate at low speed.

When $Tr < Ts$, the outdoor unit will stop, and the indoor fan will stop for 3 minutes, then operate at the low speed option.

Automatic fan speed:

When $Tr \geq Ts + 9^{\circ}\text{F}$, High speed

When $Ts + 5.4^{\circ}\text{F} \leq Tr < Ts + 9^{\circ}\text{F}$, Medium speed

When $Ts + 3.6^{\circ}\text{F} \leq Tr < Ts + 5.4^{\circ}\text{F}$, Low speed

When $Tr < Ts + 3.6^{\circ}\text{F}$, Light speed

Note: TURBO and QUIET mode must be set using the remote controller.

If the outdoor fan is stopped, the indoor fan will pause for 3 minutes.

If the outdoor fan is stopped for more than 3 minutes, and the compressor is still operating, the system will change to light speed mode.

Indoor Unit

To enter the dry mode, point the infrared remote control at

the indoor unit and press the power button, then press the DRY mode button if not already set to dry mode.

The signals received by the infrared receiver are relayed to the main board of the indoor unit to turn the system on and set it to dry mode.

The indoor unit main board will illuminate the display, indicating the set temperature and current status of the unit.

The PCB will then signal the louver stepper motor to open the louver to either a stationary position, or one of several oscillating modes.

As the louver opens, the indoor fan motor will operate at the speed last set. The fan motor has a feedback circuit which provides the main board with information for controlling the speed of the fan motor.

Temperature Sensors

The indoor unit has two sensors that provide temperature information to the PCB. An ambient temperature sensor and pipe temperature sensor are used for controlling the system during dry mode. The resistance values of the sensors will vary with temperature. The resistance to temperature values can be found using a temperature /resistance chart specific to the sensor being checked.

Communication

The indoor and outdoor unit main boards communicate via a digital signal on the wire connected to terminal 3 of each unit. A splice or break in this wire will cause a communication error.

When a command is received from the remote control, the indoor unit main board communicates with the outdoor unit main board via the terminal 3 wire to perform the requested function.

Outdoor Unit

Upon a request for dry mode, the outdoor unit main board applies power to the fan motor and compressor. Depending on system cycling, there may be up to a 3 minute wait period before the compressor and outdoor fan start.

The outdoor unit PCB also controls the position of the EEV (Electronic Expansion Valve) to regulate the flow of refrigerant to the indoor unit evaporator coil

Temperature Sensors

Four temperature sensors located in the outdoor unit provide information to the outdoor unit PCB for control of the system during dry mode.

The outdoor ambient temperature sensor provides the temperature of the air drawn into the condenser coil.

The defrost temperature sensor provides the temperature sensed at the output of the condenser coil.

The suction line temperature sensor provides the temperature sensed at the incoming suction line pipe.

The compressor discharge sensor provides the temperature sensed at the discharge pipe of the compressor.

To stop dry mode, press the power button to turn the system off, or change to another mode.

Defrost Operation

To enter the defrost mode, the compressor must have accumulated 10 minutes of run time, and 45 minutes of accumulated run time since the last defrost cycle.

When the defrost cycle begins, the following conditions take place:

1. The compressor will stop for 1 minute
2. The outdoor fan will continue to operate at high speed.
3. After 50 seconds, the 4-way valve will shift to the cool mode position.
4. 5 seconds later the outdoor fan will stop.
5. After 1 minute, the compressor will start.

The outdoor unit will now defrost.

The defrost cycle runs continuously for approximately 10 minutes.

The system will exit the defrost cycle if any of the following conditions are met:

1. The condenser maintains a temperature above 45°F for 80

seconds.

2. The condenser maintains a temperature above 54°F for 5 seconds.

Upon exiting the defrost cycle, the following conditions will take place:

1. The compressor will stop.
2. The outdoor fan will operate at high speed.
3. 50 seconds later the 4-way valve will shift to the heat mode position.
4. 60 seconds later the compressor will start.

The system resumes normal operation.

1. Compressor High Temperature

The compressor discharge pipe sensor (exhaust temp) senses the temperature of the refrigerant exiting the compressor. The sensed temperature received from the sensor by the control circuitry will cause the compressor frequency to increase or decrease. (see chart below). If a temperature of $\geq 230^\circ\text{F}$ is sensed for 20 seconds, an exhaust overheating protection error code will be indicated at the outdoor unit.

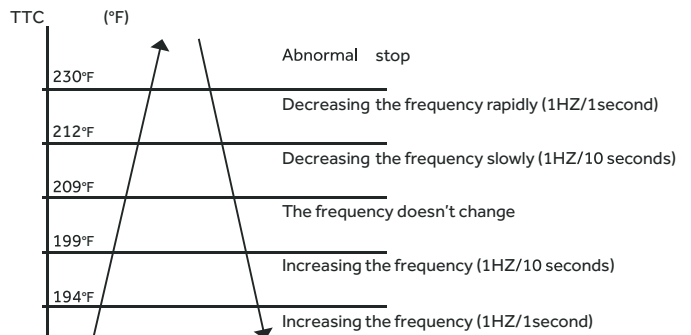

2. Overheating Protection for Indoor Unit

A sensor monitors coil temperature in both heating and cooling modes, and causes the compressor to speed up, slow down, or stop, according to the chart below.

Overheating Protection for Indoor Unit					
Model	Increasing slowly	Holds value	Decreasing slowly	Decreasing rapidly	Compressor stops
09K	40°C/104°F	52°C/126°F	57°C/135°F	60°C/140°F	63°C/145°F
12K	40°C/104°F	52°C/126°F	57°C/135°F	60°C/140°F	63°C/145°F

3. Compressor Over-current Protection

If the current draw of the compressor at start-up is greater than the values listed on the chart below for approximately 3 seconds, the compressor will stop. After 3 minutes the compressor will restart. If the over-current condition occurs 3 times in 20 minutes, the system will lock-out, and a code will be indicated at the outdoor unit. It will be necessary to remove power to the system to reset the lock-out condition.

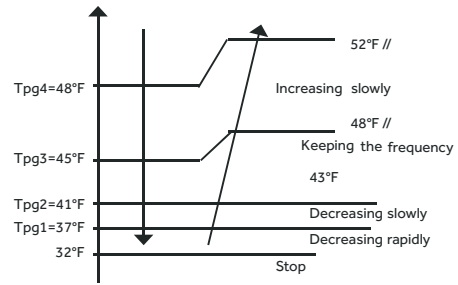

Current Overload Protection				
Model	Holds value	Decrease 1Hz/10s	Decrease 1Hz/s	Over-current point
09K	8A	9A *	10A	12A
12K	8A	9A	10A	12A

4. Anti-freeze Protection of the Indoor Coil

The temperature sensed by the coil sensor is used to determine at what speed the compressor is to run to avoid the coil temperature being too cold.

Tpg_indoor: indoor unit pipe sensor temperature

Ts: outdoor unit Suction Line sensor temperature

When $\text{Min}(T_{pg_indoor}, (T_{pg_indoor} + T_s) / 2) < T_{pg1}$, the frequency of the compressor decreases at the rate of 1HZ / 1 second.

When $\text{Min}(T_{pg_indoor}, (T_{pg_indoor} + T_s) / 2) < T_{pg2}$, the frequency of the compressor decreases at the rate of 1HZ / 10 second.

When Tpg_indoor begins to rise again, and $T_{pg2} \leq \text{Min}(T_{pg_indoor}, (T_{pg_indoor} + T_s) / 2) \leq T_{pg3}$, the frequency of the compressor does not change.

When $T_{pg3} < \text{Min}(T_{pg_indoor}, (T_{pg_indoor} + T_s) / 2) < T_{pg4}$, the frequency of the compressor increases at the rate of 1HZ / 10 second

Example: if $\text{Min}(T_{pg_indoor}, (T_{pg_indoor} + T_s) / 2) \leq 32^\circ\text{F}$ sustains for 2 minutes, the outdoor unit will stop and indicate an underload malfunction code at the outdoor unit. The compressor stops for a minimum of 3 minutes. When $\text{Min}(T_{pg_indoor}, (T_{pg_indoor} + T_s) / 2) > T_{pg4}$, the compressor will restart

Special Functions

Auto Restart

When this is enabled, the following functions will automatically resumes after a power loss:

- ON/OFF State, Mode of Operation, Fan Speed, Temperature Setpoint, Louver Swing settings.
- If there was a timer set or the system was in Sleep mode, they will be canceled upon restart

Wired Controller:

- Auto Restart is Enabled by Default

Wireless Controller:

- Enable: Press the Sleep button 10 times within 7 seconds. You will hear 4 beeps as confirmation
- Disable: Press the Sleep button 10 times within 7 seconds. You will hear 2 beeps as confirmation

Timed Defrost

Timed Defrost via Remote Controller (YR-HG): (Same as dip switch 1 and 2 OFF)

Setting method:

1. Set to HEAT Mode
2. Set to 30°C/86°F
3. Set High Fan Speed
4. Press Temperature + Button 10 times within 7 seconds
5. Hear Unit will Beep 7 times to Confirm

Cancel method:

Same process as Setting Method. Hear Unit Beep 5 times to confirm of cancel function.

Demand Defrost

Force defrost via Remote Controller (YR-HG):

Setting method:

- 1) Set to HEAT Mode
- 2) Set to 30°C/86°F
- 3) Set High Fan Speed
- 4) Press Health Button 10 times within 5 seconds
- 5) Hear Unit will Beep 4 times to Confirm, System will enter Force Defrost mode.

Indoor Temperature Display

This function will allow you to set the display to show either the Ambient temperature or the setpoint:

Set temperature: Press the Light button 10 times within 5 second, Hear Unit will Beep 4 times to confirm

Ambient temperature: Press the Light button 10 times within 5 second, Hear Unit will Beep 2 times to confirm

Temperature Compensation

This function allows you the capability to adjust the temperature compensation offset of any indoor unit. The adjusted value is programmed into the EEPROM.

Logic: The Actual Ambient Temperature = The Display Ambient Temperature + Temperature Compensation

Guide:

1. Apply power to the unit.
2. Set to Cooling Mode or Heating Mode
3. Set the temperature to 24 °C.
4. Press the SLEEP button 7 times within 5 seconds. Indoor PCB will Beep 2 times to confirm.
5. 24 °C will be the starting/reference point for the Temperature Compensation. Temperature Compensation can be adjusted from -8 °C to +6 °C. Example: if you want to set the Temperature Compensation value by 4 °C, then set the temperature to 28 °C.
6. Once the desired value has been selected, turn OFF the unit via the YR-HG controller to save the compensation settings.

RJ45

The Bluetooth module will connect to the unit physically via RJ45 (Service Port), and connect to the laptop via USB We can use it to achieve the following functions:

1. Software Updates
2. Real Time Sensor Readings / Load Control
3. View Alerts, Fault Data, Cycle History, Graphs
4. Automated Diagnostic Tests
5. Data Collection

System Specifications

Model Name	Outdoor	1U09TE2VHA/ASH109CRDWA	1U12TE2VHA/ASH112CRDWA
	Indoor	AW09TE2VHA/ASYW09CRDWA	AW12TE2VHA/ASYW12CRDWA
Cooling	Rated Capacity <i>Btu/hr</i>	9,000	12,000
	Capacity Range <i>Btu/hr</i>	3,800~10,000	4,100~13,000
	Rated Power Input <i>W</i>	800	1,100
	SEER	18	18
	EER	11.0	11.0
	0F Cooling Without Wind Baffle	5000-->4000	5800.0
	-4F Cooling with Wind Baffle	5000.0	6800.0
	Moisture Removal <i>Pt./h</i>	2.30	2.60
Heating	Rated Heating Capacity 47°F <i>Btu/hr</i>	10,000	12,000
	Heating Capacity Range <i>Btu/hr</i>	4,100~11,000	4,500~13,000
	Rated Power Input <i>W</i>	750	980
	HSPF	10.0	10.0
	Rated Heating Capacity 17°F <i>Btu/hr</i>	5,000	7,500
	Max. Heating Capacity 17°F <i>Btu/hr</i>	9,000	10,000
	Max. Heating Capacity 5°F <i>Btu/hr</i>	8,000	8,500
	Max. Heating Capacity -4°F <i>Btu/hr</i>	6,500	7,500
NEEP	Tier 1	Tier 1	
Operating Range	Cooling °F(°C)	14°F~115°F(-10~46°C)	14°F~115°F(-10~46°C)
	Heating °F(°C)	-4°F~75°F (-20~24°C)	-4°F~75°F (-20~24°C)
Power Supply	Voltage, Cycle, Phase <i>V/Hz/-</i>	208/230-60-1	208/230-60-1
Outdoor Unit	Compressor Type	DC Inverter Driven Rotary	
	Maximum Fuse Size <i>A</i>	15	15
	Minimum Circuit Amp <i>A</i>	12	12
	Outdoor Noise Level <i>dB</i>	51	53
	Dimension: Height <i>in (mm)</i>	21.77 (553)	21.77 (553)
	Dimension: Width <i>in (mm)</i>	31.5 (800)	31.5 (800)
	Dimension: Depth <i>in (mm)</i>	10.83 (275)	10.83 (275)
	Weight (Ship/Net)- <i>lbs (kg)</i>	76.1 (34.5) /63.5 (28.8)	82.2 (37.3) /69.7 (31.6)
Indoor Unit	Fan Speed Stages	5 + Auto	5 + Auto
	Indoor Sound Level <i>dB</i> (Turbo/High/Med/Low/Quiet)	44/39/35/32/28	44/40/37/34/28
	Dimension: Height <i>in (mm)</i>	11.85 (301)	11.85 (301)
	Dimension: Width <i>in (mm)</i>	33.7 (856)	33.7 (856)
	Dimension: Depth <i>in (mm)</i>	7.72 (196)	7.72 (196)
	Weight (Ship/Net)- <i>lbs (kg)</i>	26.9 (12.2) /21.2 (9.6)	26.9 (12.2) /21.2 (9.6)
Refrigerate Line	Connections	Flare	Flare
	Liquid O.D. <i>in</i>	1/4	1/4
	Suction O.D. <i>in</i>	3/8	3/8
	Factory Charge <i>Oz</i>	32.8	40.6
	Maximum Line Length <i>Ft / m</i>	66/20	66/20
	Maximum Height <i>Ft / m</i>	33/10	33/10
Remote controller	Ship with	YR-HG (Haier or GE logo)	YR-HG (Haier or GE logo)
	Compatible	Cool only (No logo)	Cool only (No logo)
WiFi/App - Haier	Built-in	Built-in	Built-in
WiFi/App - GE	Built-in	Built-in	Built-in
Wind baffle	Compatible	QAWB41A	QAWB41A
Wired controller	Compatible	Compatible with YR-E16b and QACT17A/ACT17CWA with WK-B	Compatible with YR-E16b and QACT17A/ACT17CWA with WK-B
Advanced Service	GE3	Built-in	Built-in
Important Features	Self-Clean	Indoor and Outdoor via APP	Indoor and Outdoor via APP

Table of Contents

Check This First Outdoor Unit	105
Check This First Indoor Unit	106
Wiring Diagram Reference.....	107
Error Code (Indoor/outdoor).....	108
F1/LED1: 2 Flash	
F2/LED1: 24 Flash	110
F3/LED1: 4 Flash	112
F4/LED1: 8 Flash	116
F6/LED1: 12 Flash	
F7/LED1: 11 Flash	
F21/LED1: 10 Flash	
F25/LED1: 13 Flash	
E1/LED1: No Flash	
E2/LED1: No Flash	116
F6/LED1: 12 Flash, F7/LED1: 11 Flash, F21/LED1: 10 Flash, F25/LED1: 13 Flash,	
E1/LED1: No Flash, E2/LED1: No Flash.....	117
F8/LED1: 9 Flash	118
F11/LED1: 18 Flash	120
F12/LED1: 1 Flash	122
E5/LED1: 22 Flash.....	123
E7/LED1: 15 Flash	125
Error Code (Indoor)	
E14	128
Checking System Components.....	130

Check This First

Indoor Unit

Models:

AW09TE2VHA
 AW12TE2VHA
 ASYW09CRDWA
 ASYW12CRDWA

See reverse side for wiring diagram and relevant color-coded test positions.

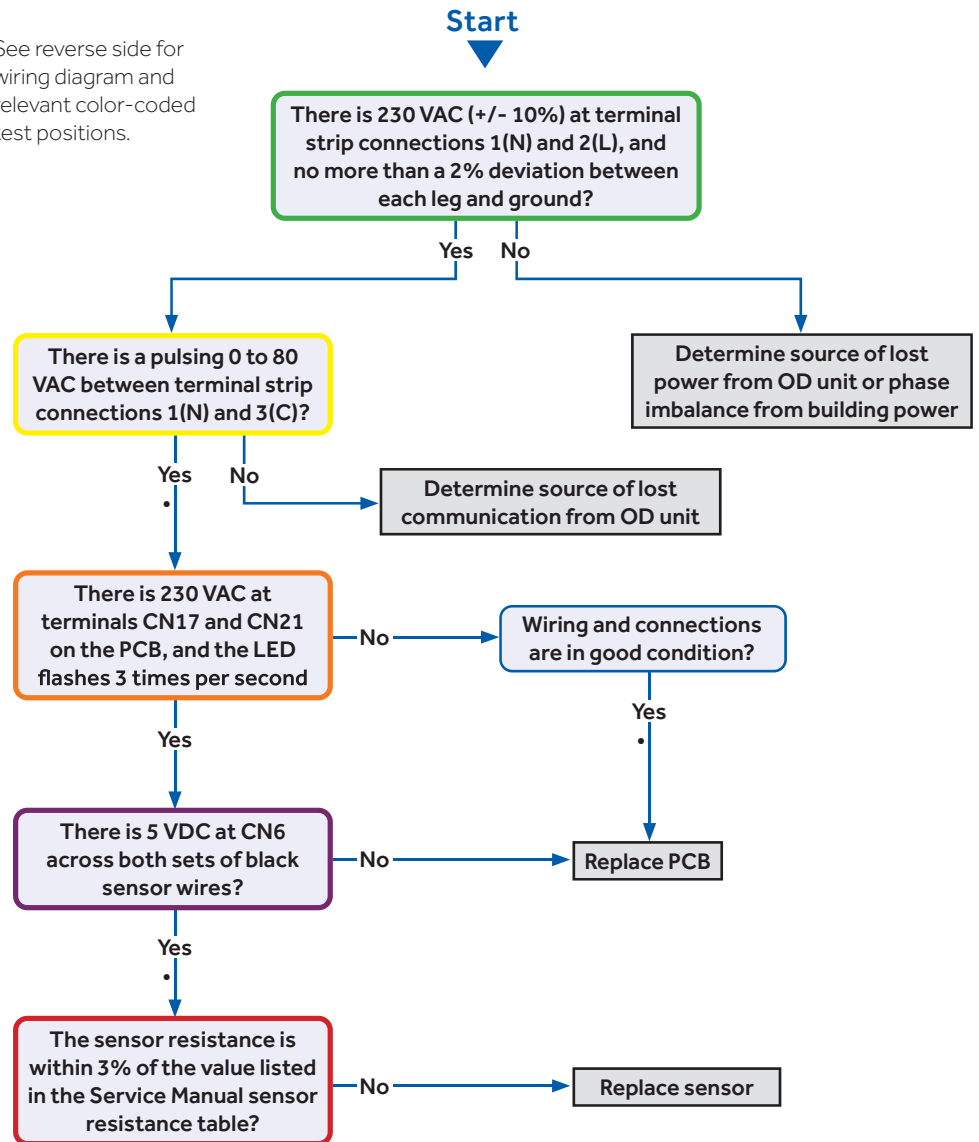

Troubleshooting

Check This First - Indoor Unit

Wiring Diagram Reference

Sensor Resistance Table

°F	°C	Normal (KΩ)		
		10K SENSORS	23K SENSORS	50K SENSORS
-0.4	-18	75.44	235.90	5494.21
5.0	-15	64.30	196.61	4558.19
10.4	-12	54.99	164.40	3795.39
14.0	-10	49.62	146.15	3365.73
21.2	-6	40.58	115.95	2658.81
24.8	-4	36.77	103.46	2368.32
32.0	0	30.30	82.69	1887.00
35.6	2	27.55	74.07	1687.81
41.0	5	23.95	62.94	1431.28
44.6	7	21.84	56.57	1284.36
50.0	10	19.06	48.31	1094.32
55.4	13	16.68	41.40	934.94
59.0	15	15.28	37.41	843.05
64.4	18	13.42	32.22	723.41
69.8	21	11.81	27.83	622.32
75.2	24	10.42	24.11	536.65
77.0	25	10.00	23.00	511.08
80.6	27	9.21	20.95	464.05
86.0	30	8.16	18.25	402.24
89.6	32	7.54	16.67	366.13
95.0	35	6.70	14.59	318.52
100.4	38	5.97	12.79	277.70

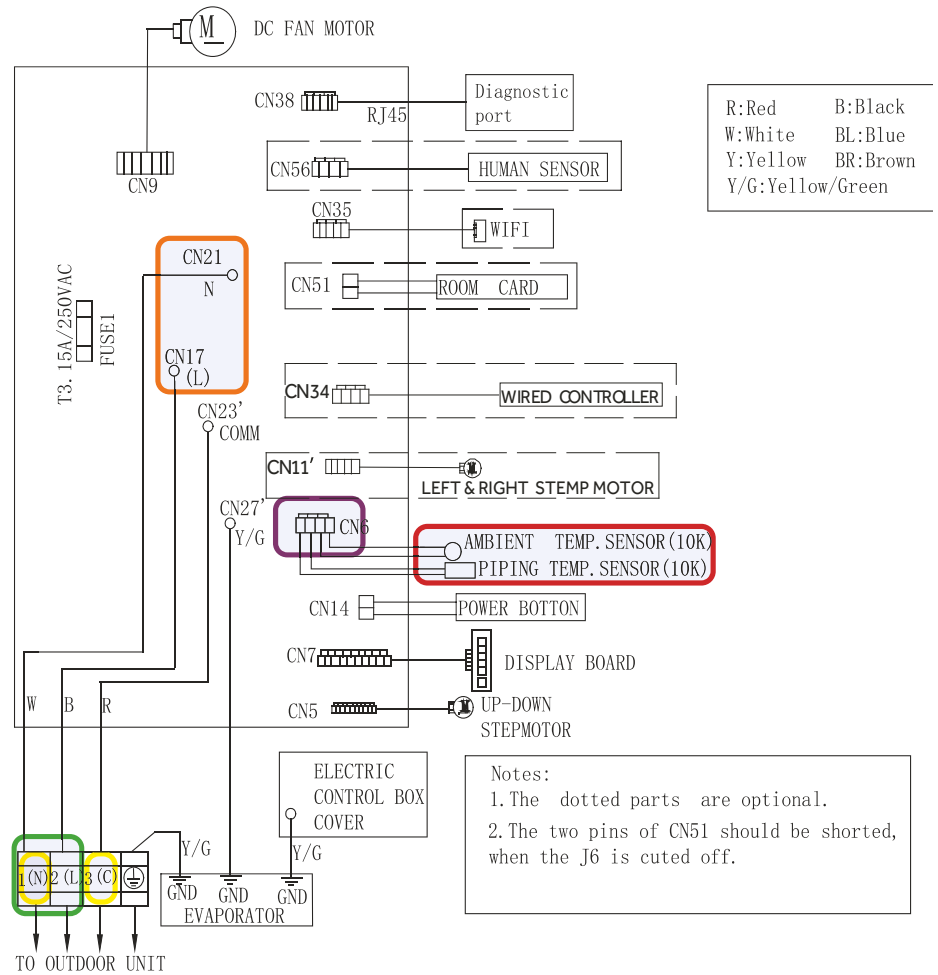

Model selection:

09K	model-23	code - BM1	- 1 off	2 off	Notes: Before replacing the board, it is necessary to ensure that the machine is matched with the board code
12K	model-26	code - BM1	- 1 off	2 on	
07K	model-33	code - BM1	- 1 on	2 off	
18K	model-36	code - BM1	- 1 off	2 off	

Troubleshooting

Error Code (Indoor/Outdoor)

F1/LED1: 2 Flash

IPM Power Module Fail
(IPM power module protection)

Complete the "Check This First" Flow Chart before continuing.

Models:

AW09TE2VHA
AW12TE2VHA
ASYW09CRDWA
ASYW12CRDWA

1U09TE2VHA
1U12TE2VHA
ASH109CRDWA
ASH112CRDWA

See reverse side for wiring diagram and relevant color-coded test positions.

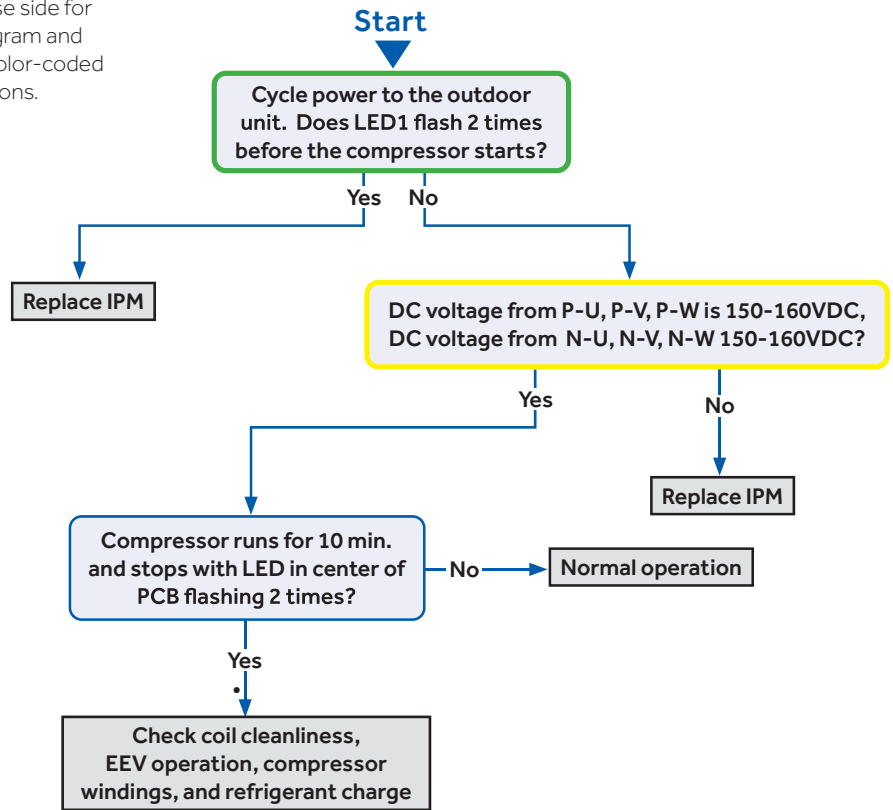

Troubleshooting

Error Code: F1/LED1: 2 Flash

Wiring Diagram Reference

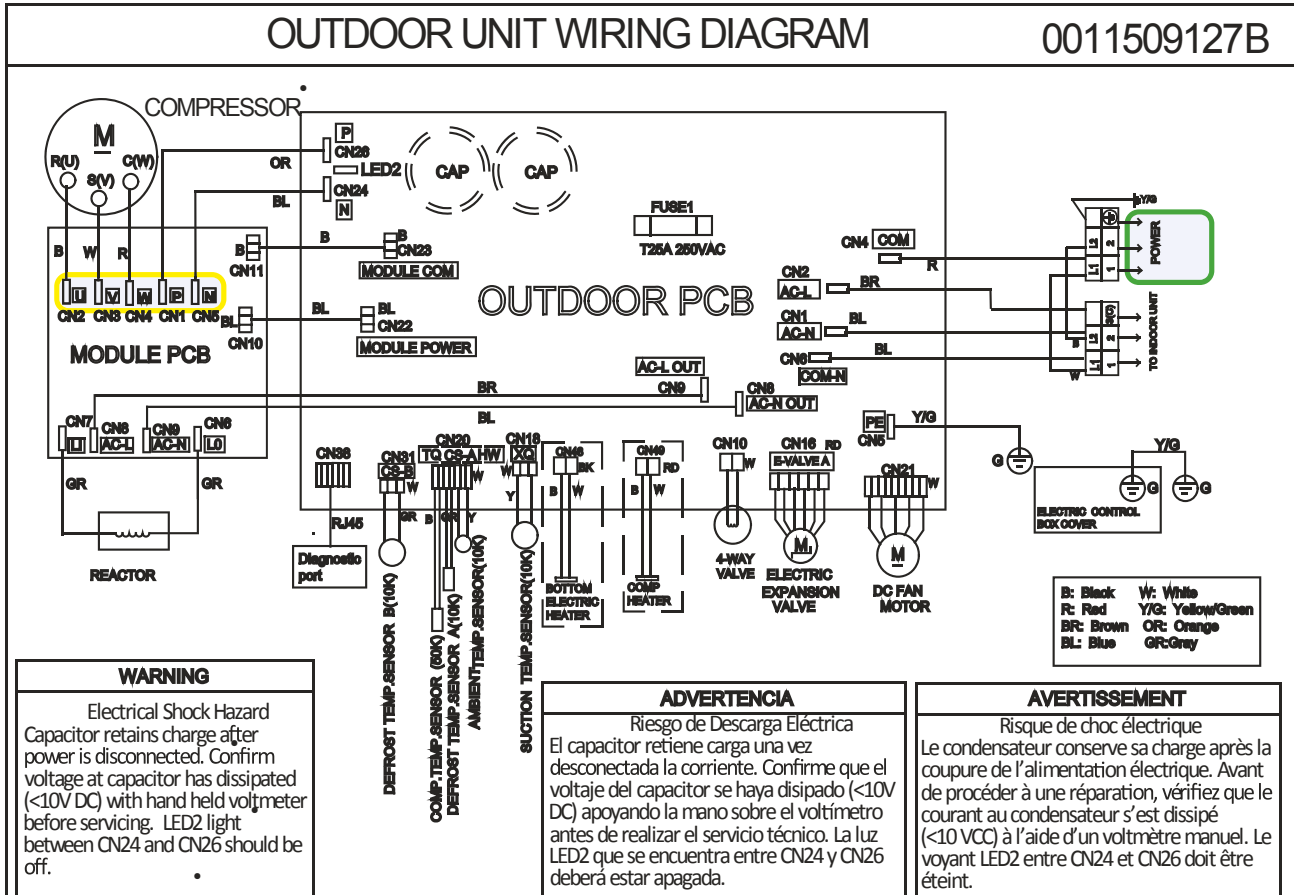

EEV Resistance Values

EEV (6-pin, 5 wire)

	White	Yellow	Orange	Blue	X	Red
White	-	92 Ω	92 Ω	92 Ω	-	46 Ω
Yellow	-	-	92 Ω	92 Ω	-	46 Ω
Orange	-	-	-	92 Ω	-	46 Ω
Blue	-	-	-	-	-	46 Ω
X	-	-	-	-	-	-
Red	-	-	-	-	-	-

EEV (6-pin, 6 wire)

	White	Yellow	Orange	Blue	Brown	Red
White	-	OL	92 Ω	OL	46 Ω	OL
Yellow	-	-	OL	92 Ω	OL	46 Ω
Orange	-	-	-	OL	46 Ω	OL
Blue	-	-	-	-	OL	46 Ω
Brown	-	-	-	-	-	OL
Red	-	-	-	-	-	-

Troubleshooting

Error Code (Indoor/Outdoor)

F2/LED1: 24 Flash

Overcurrent of the Compressor

Complete the "Check This First" Flow Chart before continuing.

Models:

AW09TE2VHA
AW12TE2VHA
ASYW09CRDWA
ASYW12CRDWA

1U09TE2VHA
1U12TE2VHA
ASH109CRDWA
ASH112CRDWA

See reverse side for wiring diagram and relevant color-coded test positions.

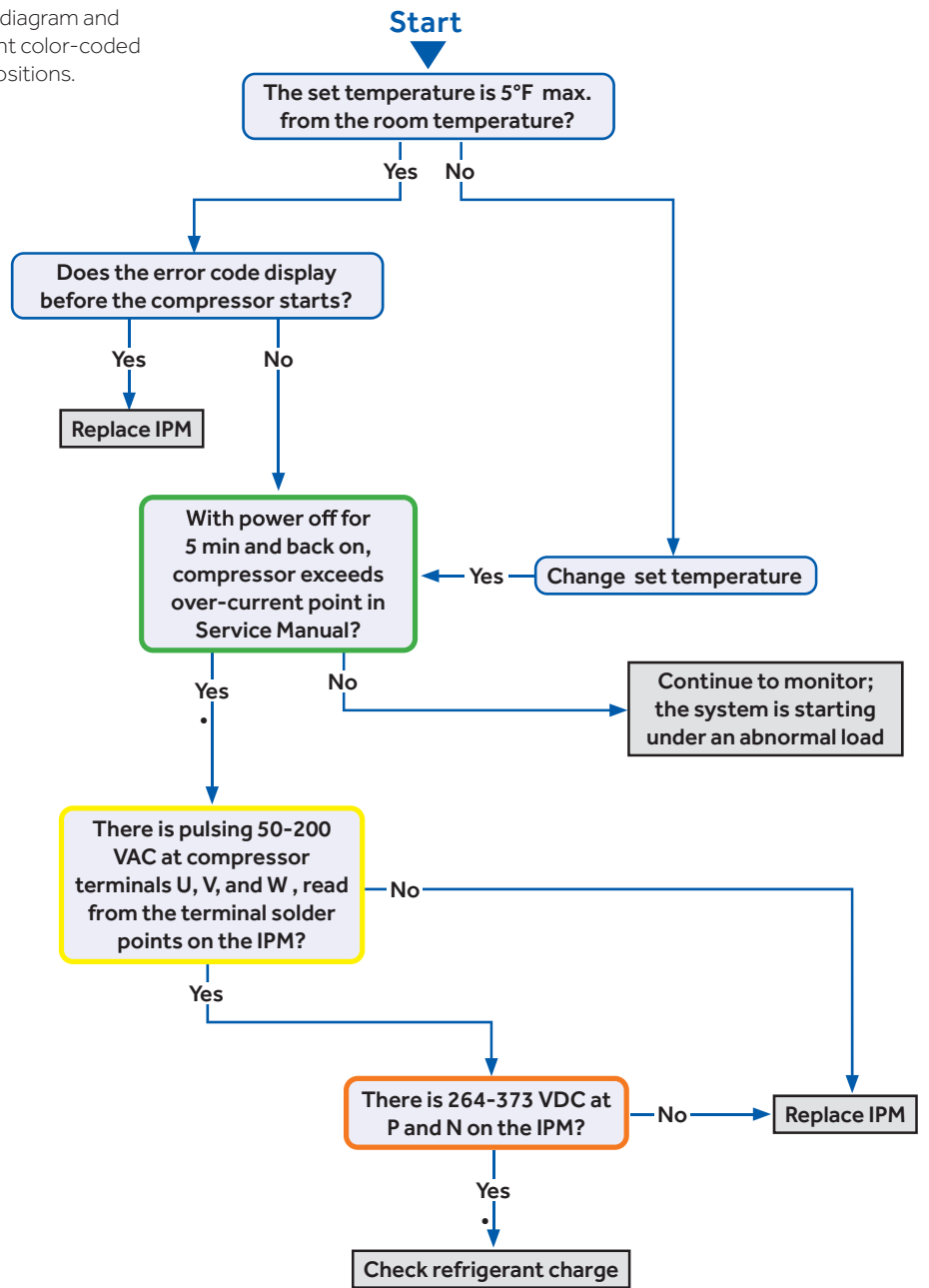

Troubleshooting

Error Code: F2/LED1: 24 Flash

Wiring Diagram Reference

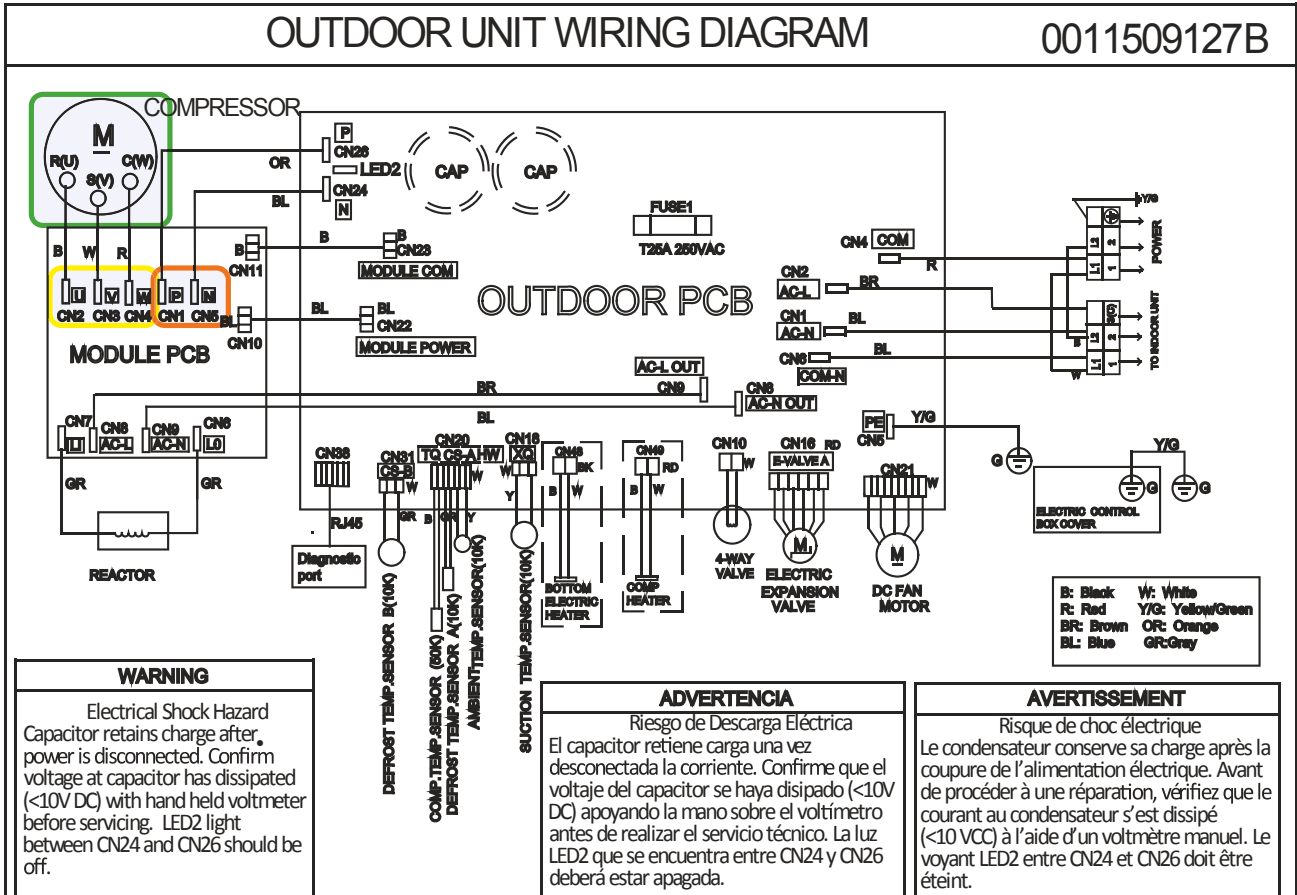

Troubleshooting

Error Code (Indoor/Outdoor)

F3/LED1: 4 Flash

Communication Fault Between IPM and Outdoor PCB

Complete the "Check This First" Flow Chart before continuing.

Models:

AW09TE2VHA
AW12TE2VHA
ASYW09CRDWA
ASYW12CRDWA

1U09TE2VHA
1U12TE2VHA
ASH109CRDWA
ASH112CRDWA

See reverse side for wiring diagram and relevant color-coded test positions.

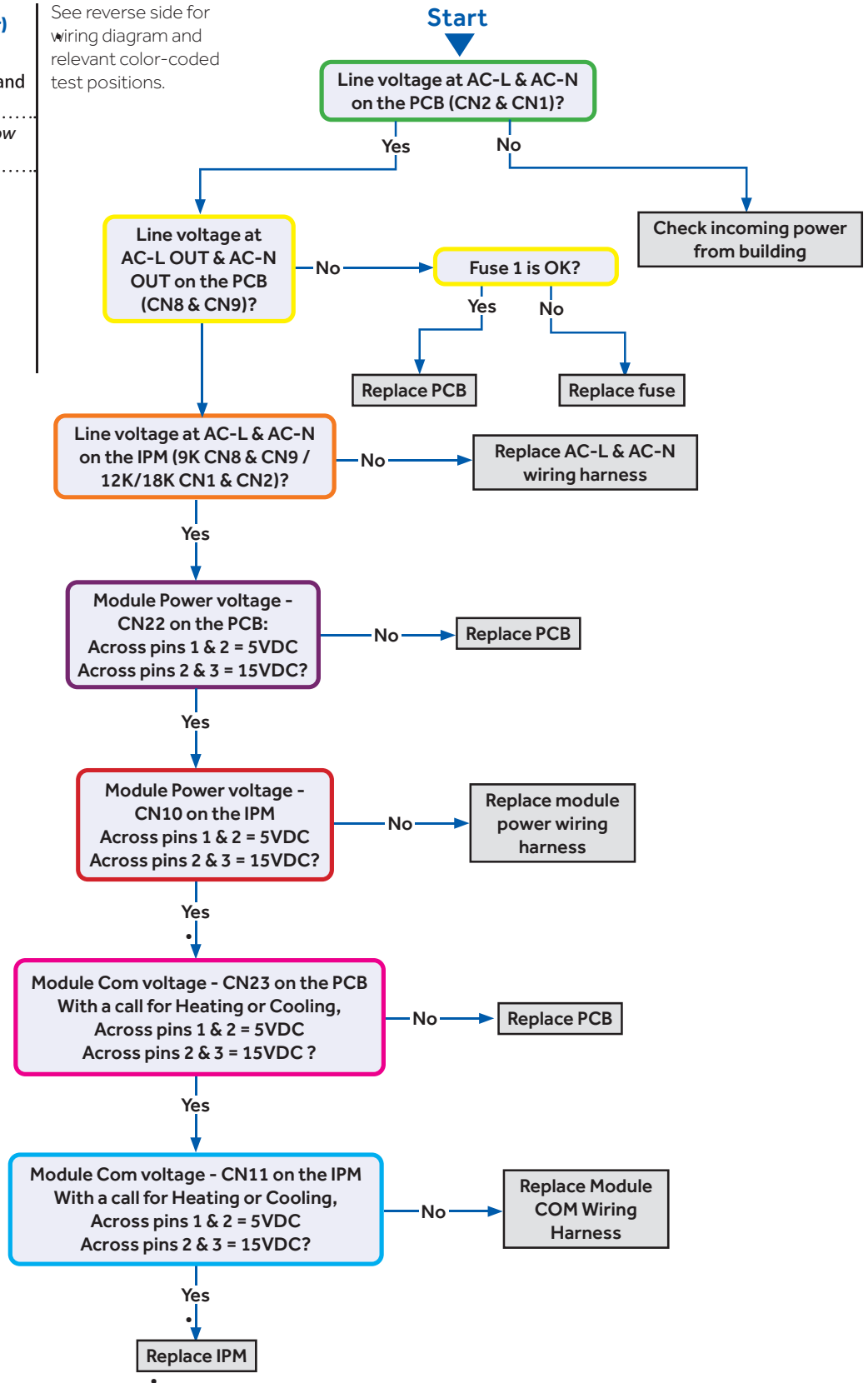

Troubleshooting

Error Code: F3/LED1: 4 Flash

Wiring Diagram Reference

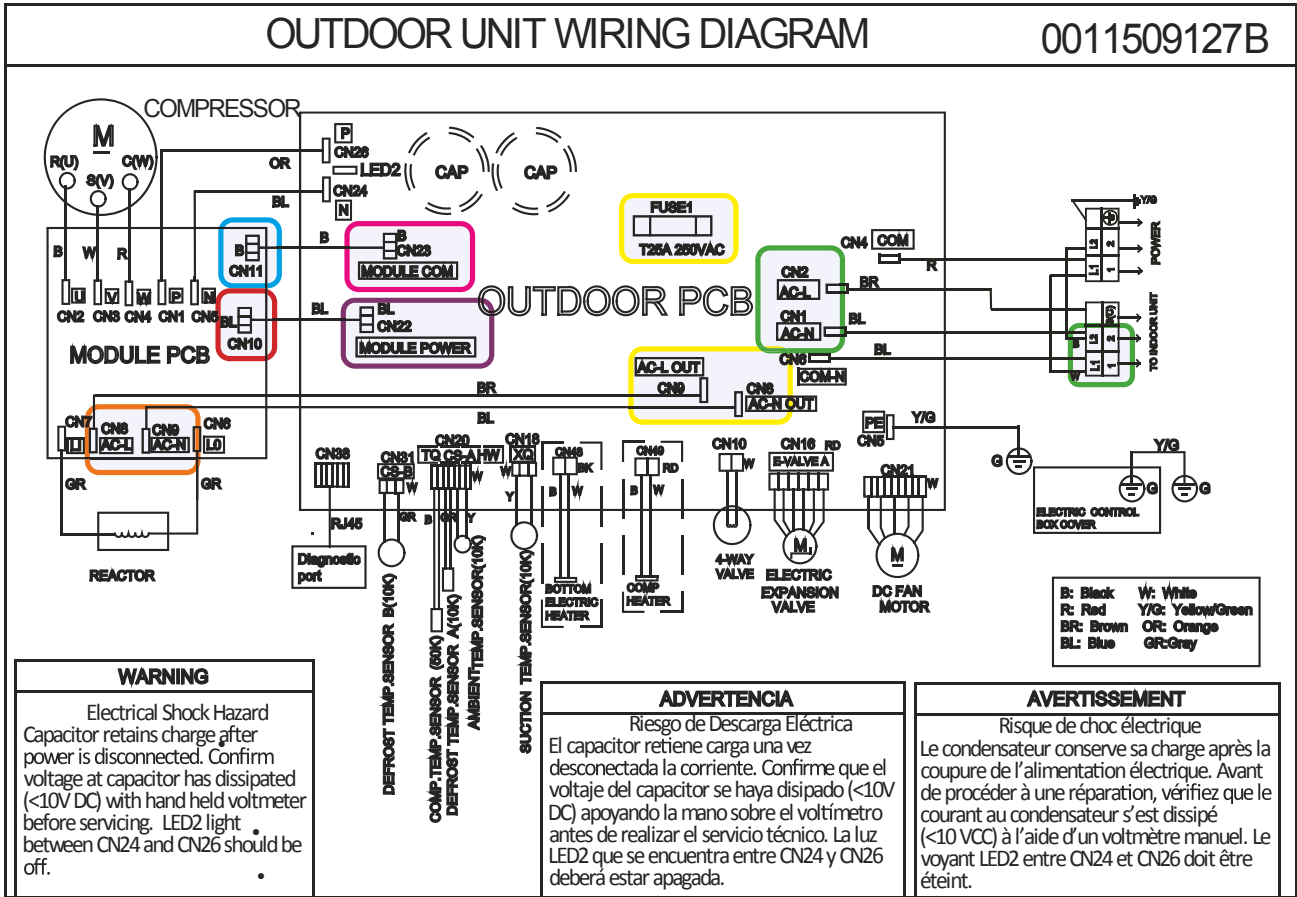

Troubleshooting

Error Code (Indoor/Outdoor)

F4/LED1: 8 Flash

Overheat Protection For Discharge Temperature

Complete the "Check This First" Flow Chart before continuing.

Models:

AW09TE2VHA
AW12TE2VHA
ASYW09CRDWA
ASYW12CRDWA

1U09TE2VHA
1U12TE2VHA
ASH109CRDWA
ASH112CRDWA

See reverse side for wiring diagram and relevant color-coded test positions.

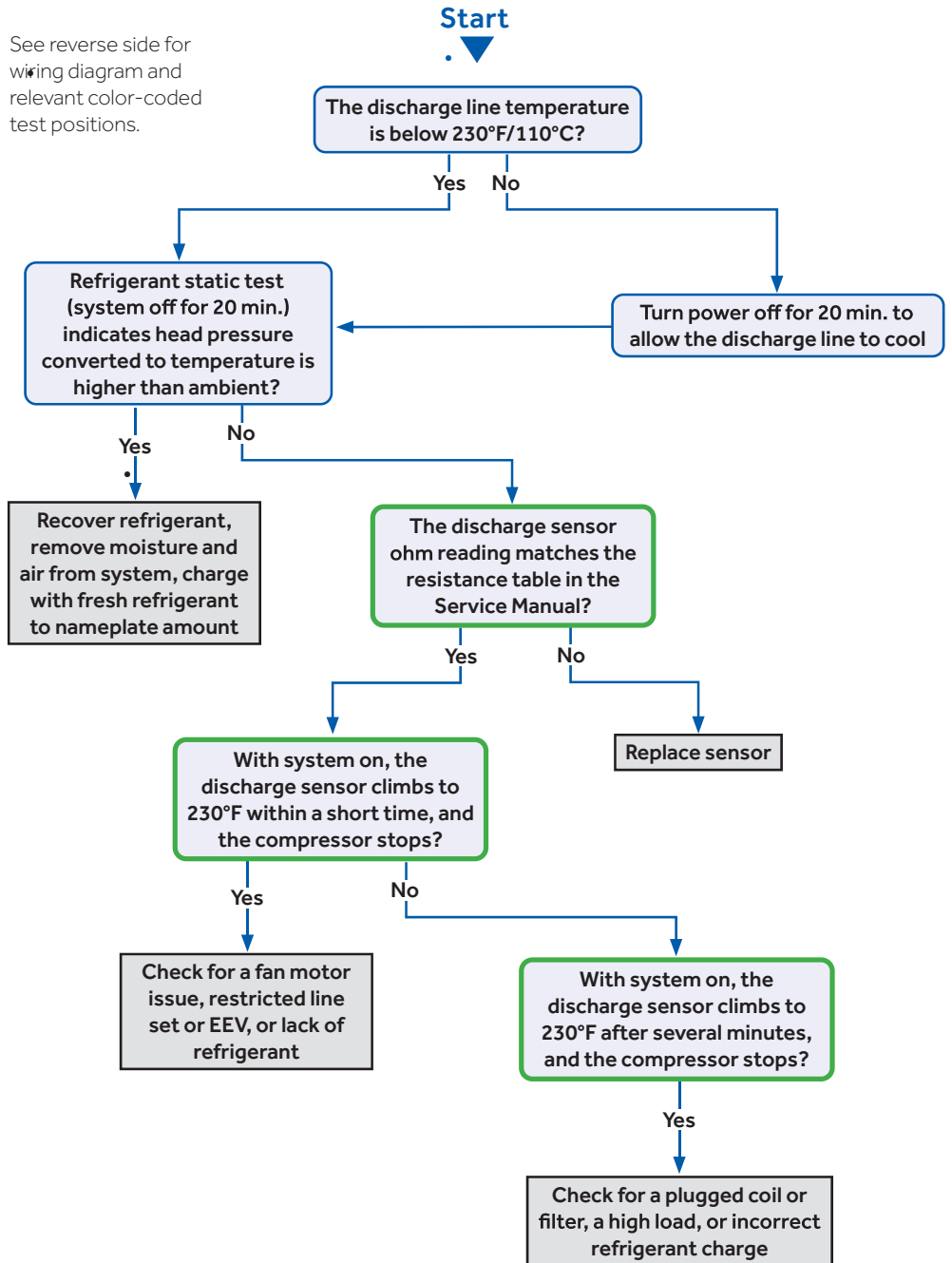

Troubleshooting

Error Codes (Indoor/Outdoor)

F6/LED1: 12 Flash
Ambient Temperature Sensor Failure

F7/LED1: 11 Flash
Suction Temperature Sensor Failure

F21/LED1: 10 Flash
Defrost Temperature Sensor Failure

F25/LED1: 13 Flash
Discharge Temperature Sensor Failure

E1/LED1: No Flash
Room Temperature Sensor Failure

E2/LED1: No Flash
Indoor Coil Temperature Sensor Failure

Complete the "Check This First" Flow Chart before continuing.

Models:

AW09TE2VHA
AW12TE2VHA
ASYW09CRDWA
ASYW12CRDWA

1U09TE2VHA
1U12TE2VHA
ASH109CRDWA
ASH112CRDWA

See reverse side for wiring diagram, relevant color-coded test positions, and sensor resistance values.

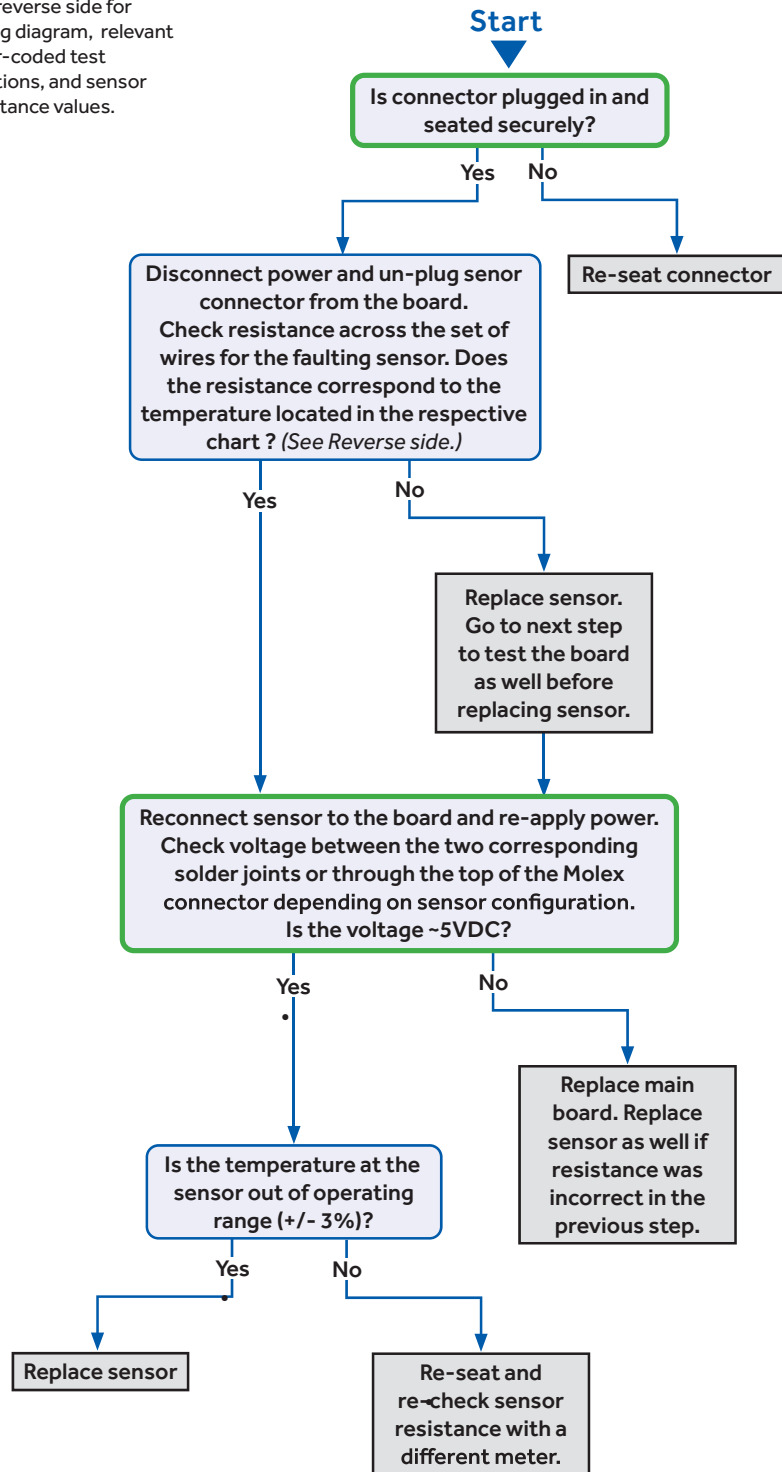

Troubleshooting

Error Code: F6/LED1: 12 Flash, F7/LED1: 11 Flash, F21/LED1: 10 Flash, F25/LED1: 13 Flash, E1/LED1: No Flash, E2/LED1: No Flash

Wiring Diagram Reference

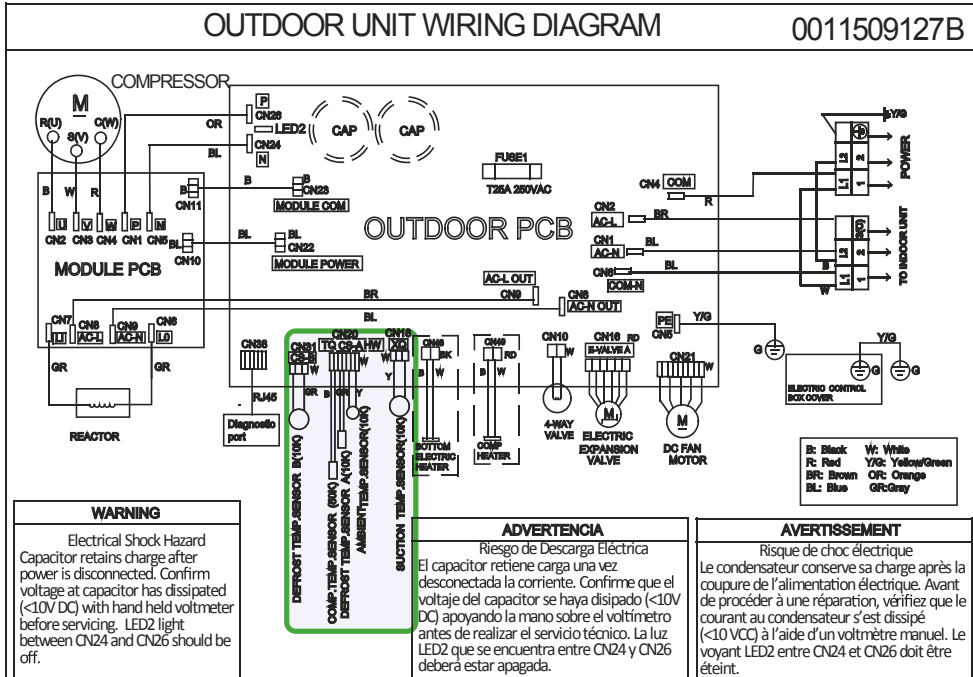

Sensor Resistance Table

°F	°C	Normal (KΩ)		
		10K SENSORS	23K SENSORS	50K SENSORS
-0.4	-18	75.44	235.90	5494.21
5.0	-15	64.30	196.61	4558.19
10.4	-12	54.99	164.40	3795.39
14.0	-10	49.62	146.15	3365.73
21.2	-6	40.58	115.95	2658.81
24.8	-4	36.77	103.46	2368.32
32.0	0	30.30	82.69	1887.00
35.6	2	27.55	74.07	1687.81
41.0	5	23.95	62.94	1431.28
44.6	7	21.84	56.57	1284.36
50.0	10	19.06	48.31	1094.32
55.4	13	16.68	41.40	934.94
59.0	15	15.28	37.41	843.05
64.4	18	13.42	32.22	723.41
69.8	21	11.81	27.83	622.32
75.2	24	10.42	24.11	536.65
77.0	25	10.00	23.00	511.08
80.6	27	9.21	20.95	464.05
86.0	30	8.16	18.25	402.24
89.6	32	7.54	16.67	366.13
95.0	35	6.70	14.59	318.52
100.4	38	5.97	12.79	277.70

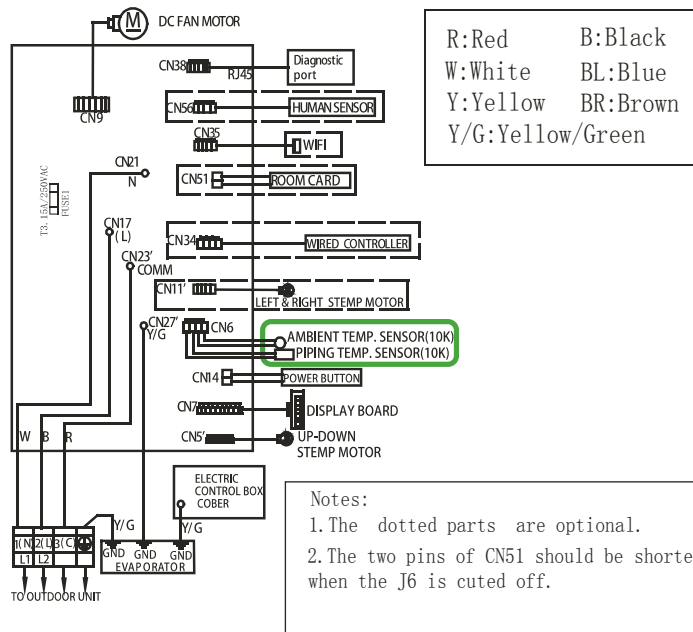

Model selection:

09K model-23 code - BM1 - 1 off 2 off
 12K model-26 code - BM1 - 1 off 2 on
 07K model-33 code - BM1 - 1 on 2 off
 18K model-36 code - BM1 - 1 off 2 off

Notes: Before replacing the board, it is necessary to ensure that the machine is matched with the board code

Troubleshooting

Error Code (Indoor/Outdoor)

F8/LED1: 9 Flash

Outdoor DC Fan Motor Fault

Complete the "Check This First" Flow Chart before continuing.

Models:

AW09TE2VHA
AW12TE2VHA
ASYW09CRDWA
ASYW12CRDWA

1U09TE2VHA
1U12TE2VHA
ASH109CRDWA
ASH112CRDWA

See reverse side for wiring diagram and relevant color-coded test positions.

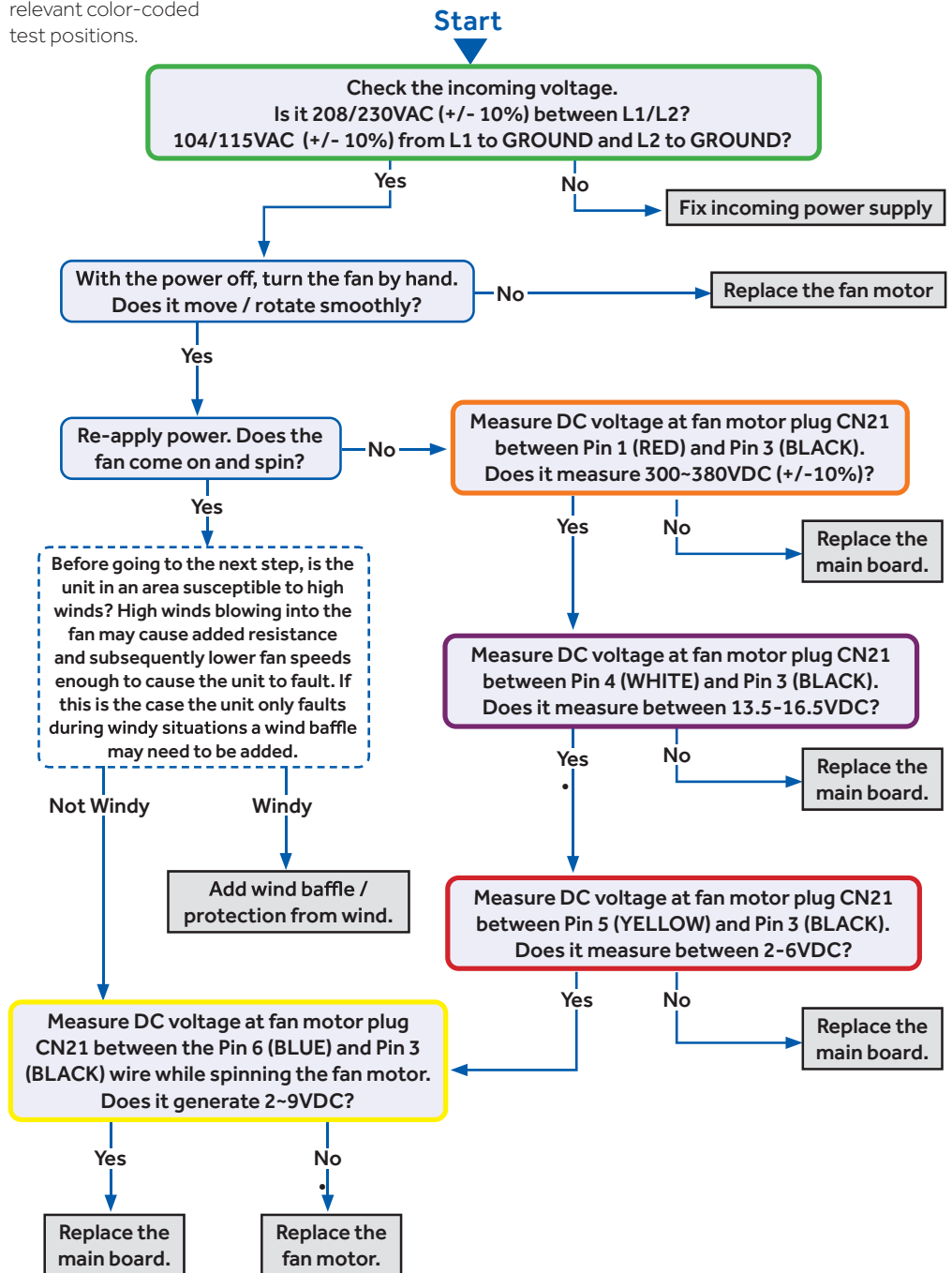

Troubleshooting

Error Code: F8/LED1: 9 Flash

Wiring Diagram Reference

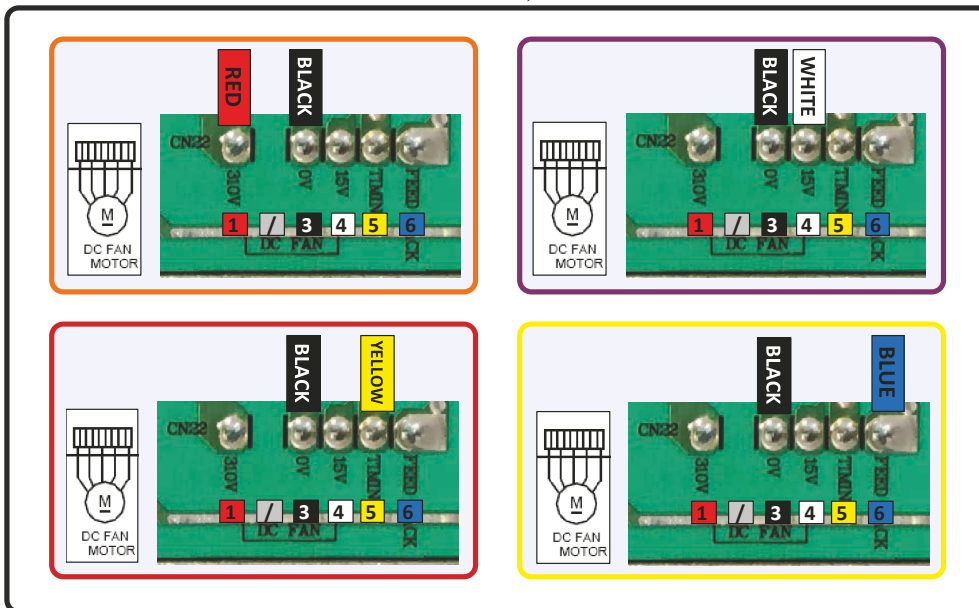
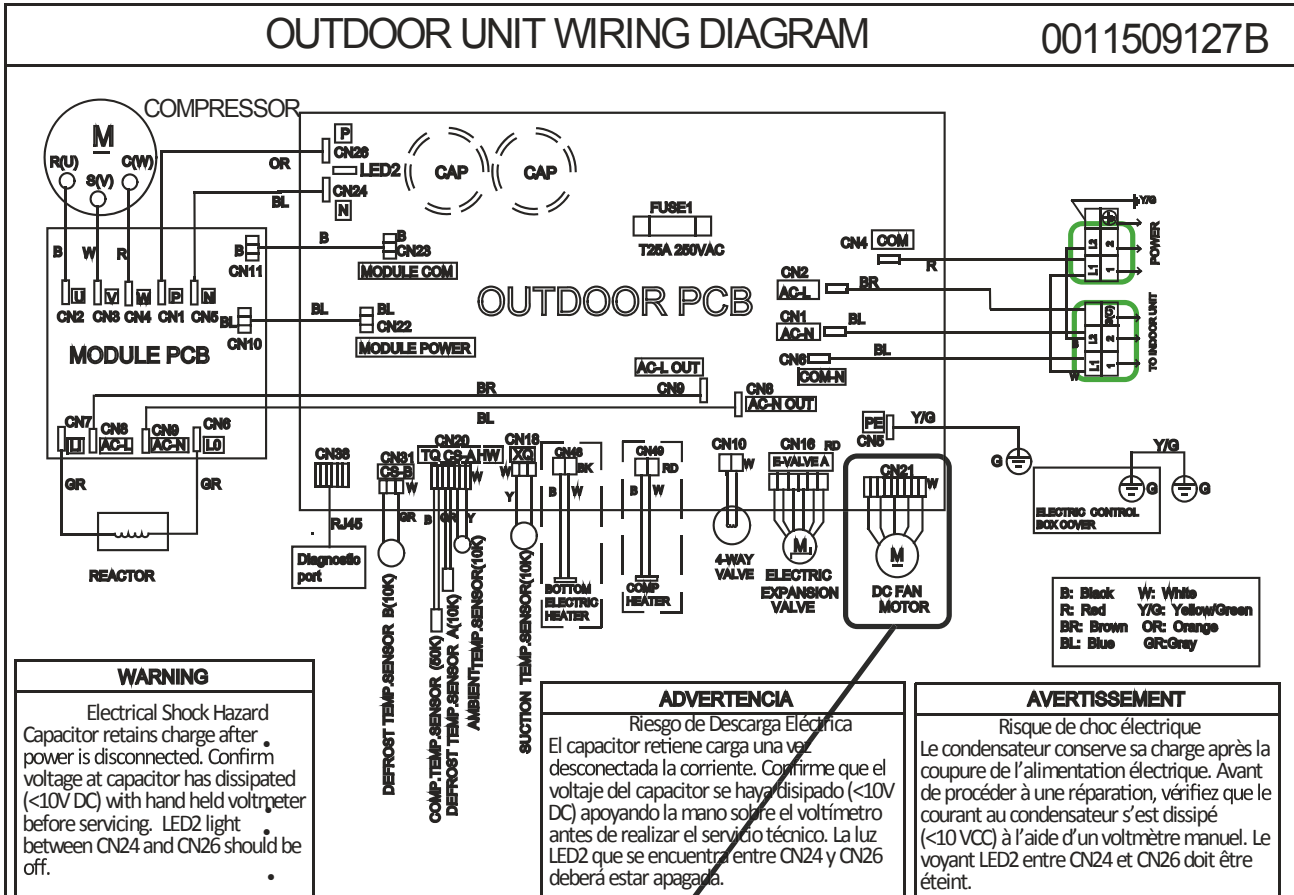

Troubleshooting

Error Code (Indoor/Outdoor)

F11/LED1: 18 Flash

Loss of Compressor Synchronization

Complete the "Check This First" Flow Chart before continuing.

Models:

AW09TE2VHA
AW12TE2VHA
ASYW09CRDWA
ASYW12CRDWA

1U09TE2VHA
1U12TE2VHA
ASH109CRDWA
ASH112CRDWA

See reverse side for wiring diagram and relevant color-coded test positions.

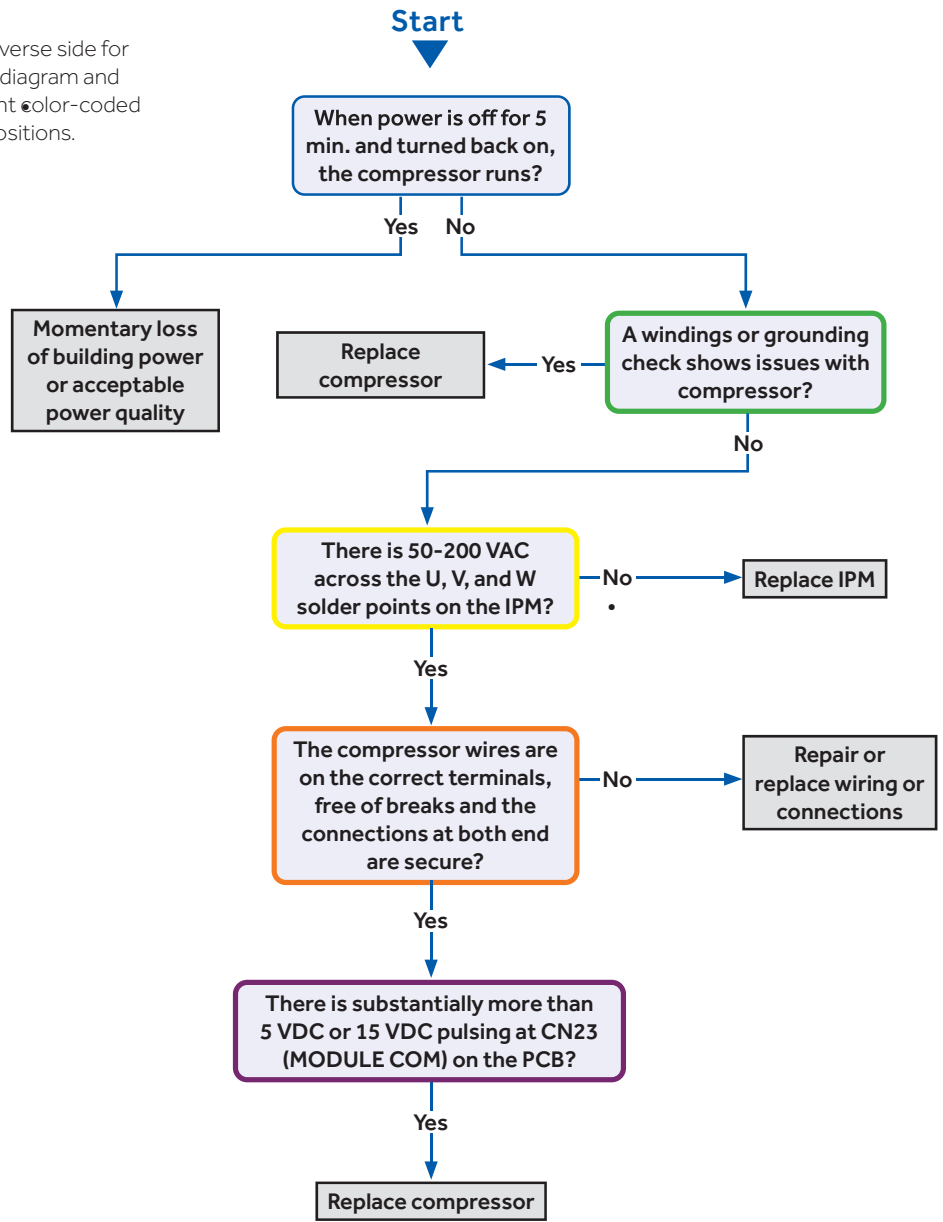

Troubleshooting

Error Code: F11/LED1: 18 Flash

Wiring Diagram Reference

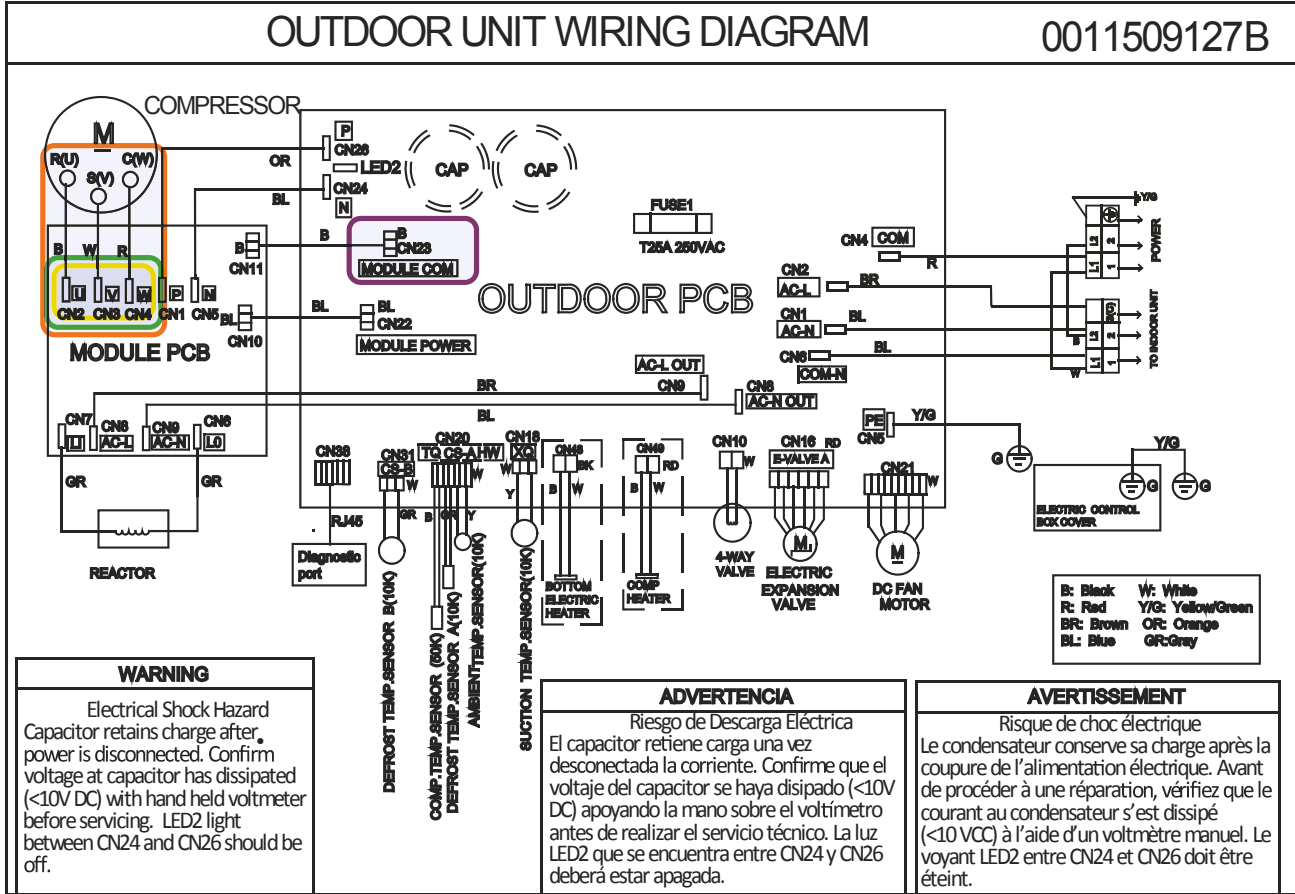

Troubleshooting

Error Code (Indoor/Outdoor)

F12/LED1: 1 Flash

EEPROM Error

Complete the "Check This First" Flow Chart before continuing.

Models:

AW09TE2VHA
AW12TE2VHA
ASYW09CRDWA
ASYW12CRDWA

1U09TE2VHA
1U12TE2VHA
ASH109CRDWA
ASH112CRDWA

See reverse side for wiring diagram and relevant color-coded test positions.

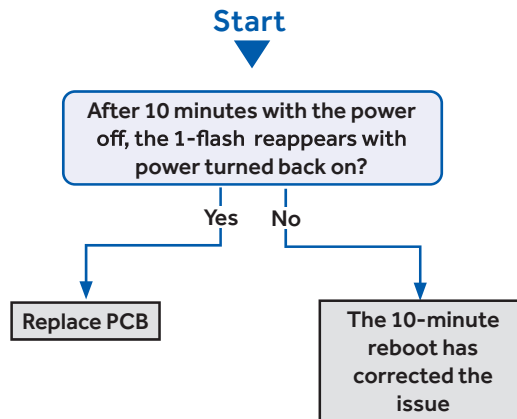

Wiring Diagram Reference

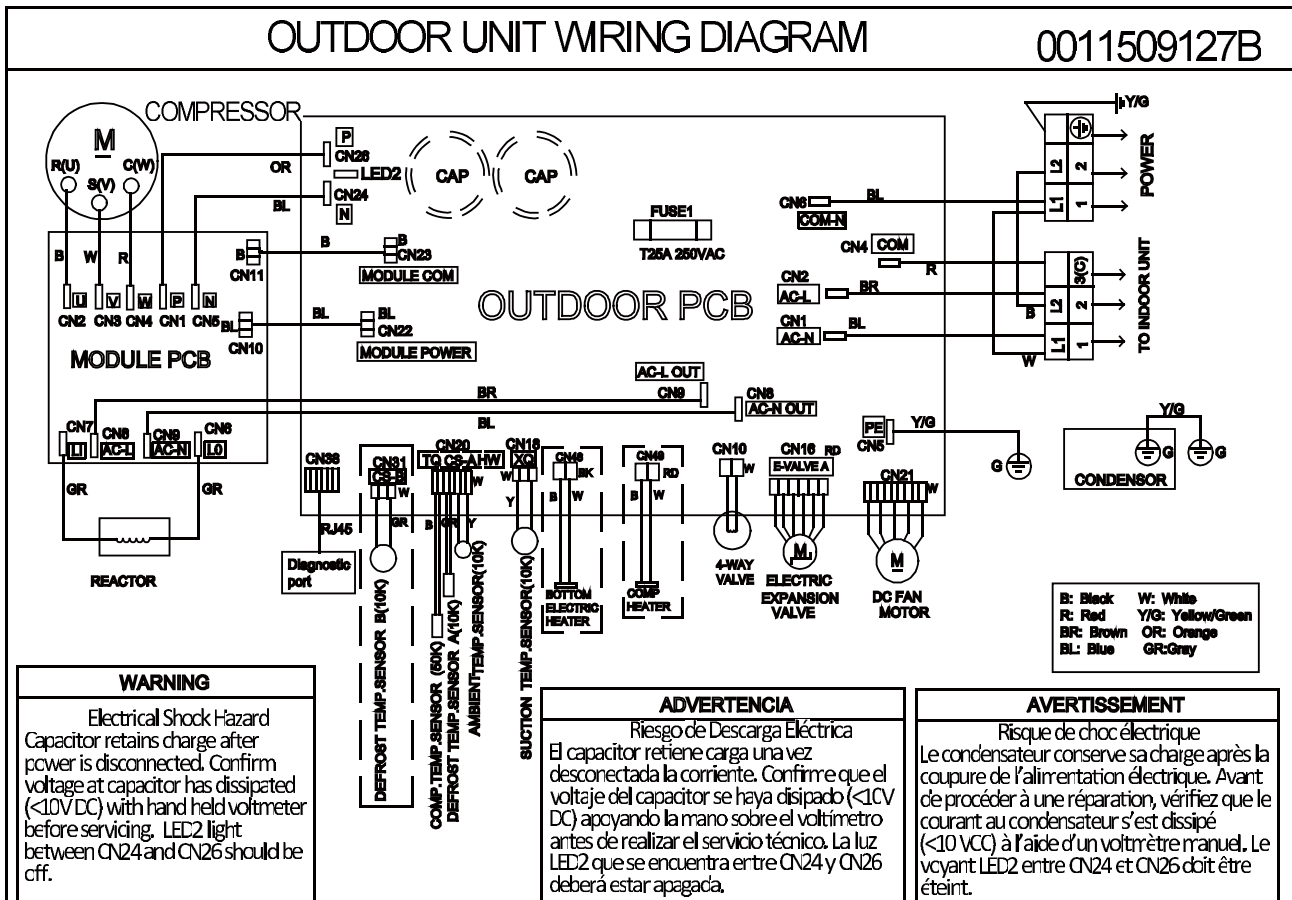

Troubleshooting

Error Code (Indoor/Outdoor)

E5/LED1: 22 Flash Coil Frost Protection

Complete the "Check This First" Flow Chart before continuing.

Models:

AW09TE2VHA
AW12TE2VHA
ASYW09CRDWA
ASYW12CRDWA

1U09TE2VHA
1U12TE2VHA
ASH109CRDWA
ASH112CRDWA

See reverse side for wiring diagram and relevant color-coded test positions.

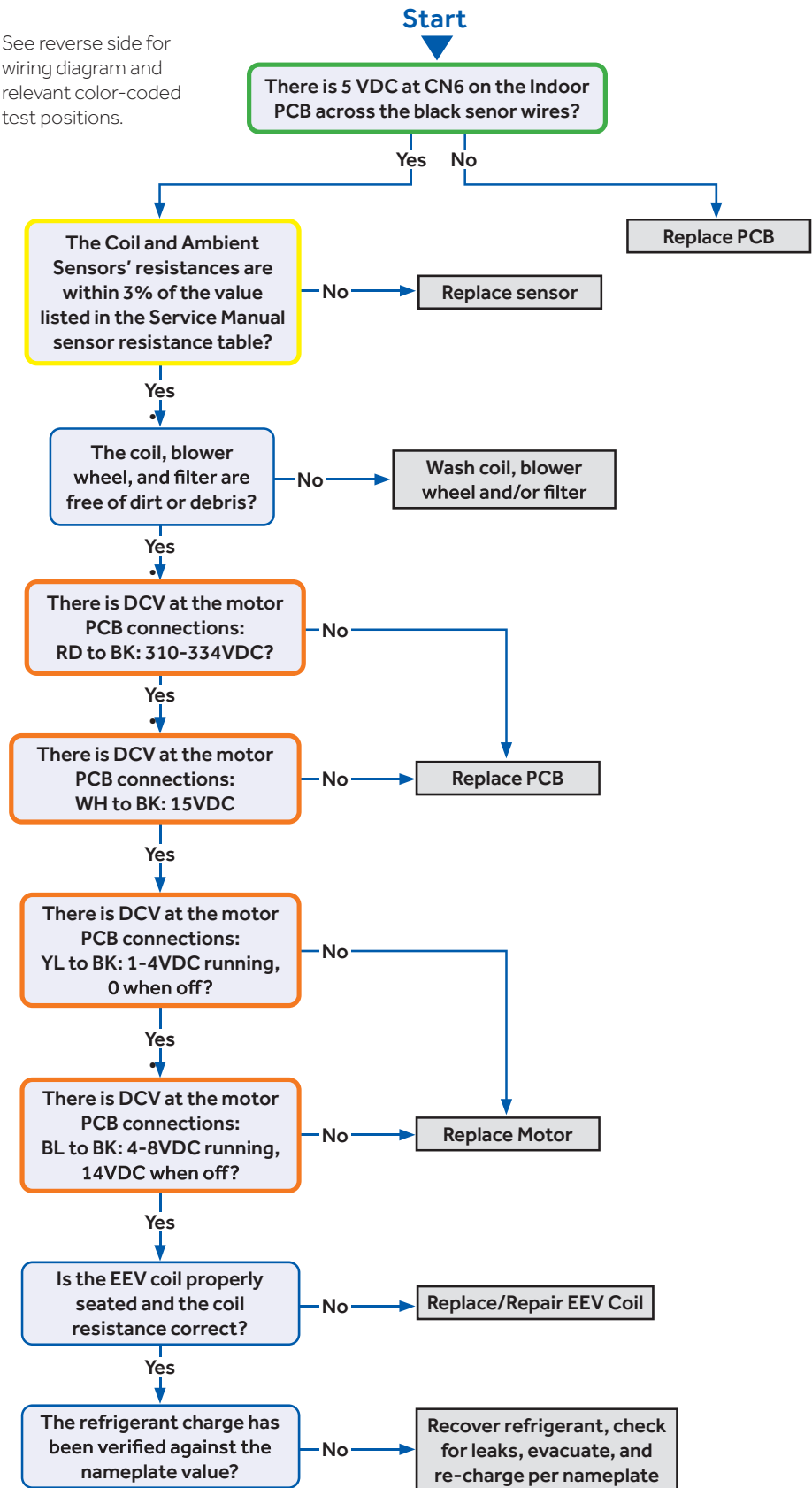

Troubleshooting

Error Code: E5/LED1: 22 Flash

Wiring Diagram Reference

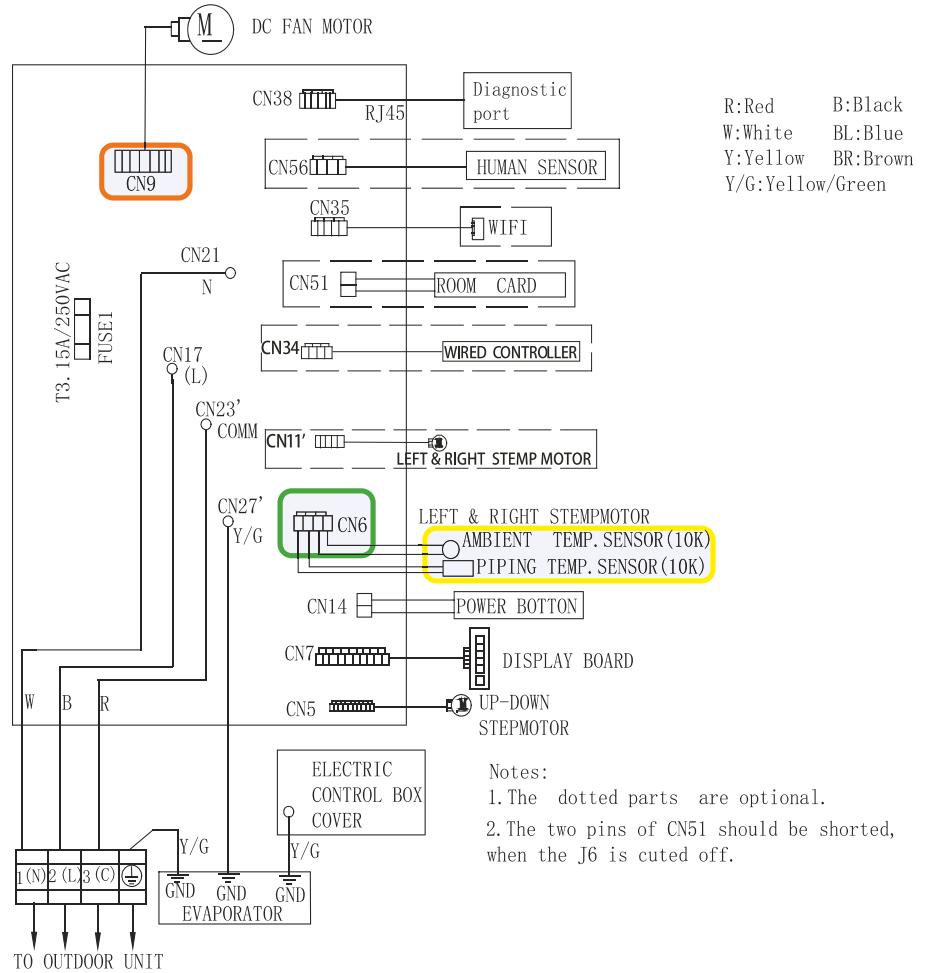

Sensor Resistance Table

°F	°C	Normal (KΩ)		
		10K SENSORS	23K SENSORS	50K SENSORS
-0.4	-18	75.44	235.90	5494.21
5.0	-15	64.30	196.61	4558.19
10.4	-12	54.99	164.40	3795.39
14.0	-10	49.62	146.15	3365.73
21.2	-6	40.58	115.95	2658.81
24.8	-4	36.77	103.46	2368.32
32.0	0	30.30	82.69	1887.00
35.6	2	27.55	74.07	1687.81
41.0	5	23.95	62.94	1431.28
44.6	7	21.84	56.57	1284.36
50.0	10	19.06	48.31	1094.32
55.4	13	16.68	41.40	934.94
59.0	15	15.28	37.41	843.05
64.4	18	13.42	32.22	723.41
69.8	21	11.81	27.83	622.32
75.2	24	10.42	24.11	536.65
77.0	25	10.00	23.00	511.08
80.6	27	9.21	20.95	464.05
86.0	30	8.16	18.25	402.24
89.6	32	7.54	16.67	366.13
95.0	35	6.70	14.59	318.52
100.4	38	5.97	12.79	277.70

- Notes:
1. The dotted parts are optional.
 2. The two pins of CN51 should be shorted, when the J6 is cuted off.

Model selection:

09K	model-23	code - BM1	- 1 off	2 off	Notes: Before replacing the board, it is necessary to ensure that the machine is matched with the board code
12K	model-26	code - BM1	- 1 off	2 on	
07K	model-33	code - BM1	- 1 on	2 off	
18K	model-36	code - BM1	- 1 off	2 off	

EEV Resistance Values

EEV (6-pin, 5 wire)

	White	Yellow	Orange	Blue		Red
White	-	92 Ω	92 Ω	92 Ω	-	46 Ω
Yellow	-	-	92 Ω	92 Ω	-	46 Ω
Orange	-	-	-	92 Ω	-	46 Ω
Blue	-	-	-	-	-	46 Ω
	-	-	-	-	-	-
Red	-	-	-	-	-	-

EEV (6-pin, 6 wire)

	White	Yellow	Orange	Blue	Brown	Red
White	-	0L	92 Ω	0L	46 Ω	0L
Yellow	-	-	0L	92 Ω	0L	46 Ω
Orange	-	-	-	0L	46 Ω	0L
Blue	-	-	-	-	0L	46 Ω
Brown	-	-	-	-	-	0L
Red	-	-	-	-	-	-

Troubleshooting

Error Code (Indoor/Outdoor)

E7/LED1: 15 Flash ID and OD Loss of Communication

Complete the "Check This First" Flow Chart for both ID and OD units before continuing.

Models:

AW09TE2VHA
AW12TE2VHA
ASYW09CRDWA
ASYW12CRDWA

1U09TE2VHA
1U12TE2VHA
ASH109CRDWA
ASH112CRDWA

See reverse side for wiring diagram and relevant color-coded test positions.

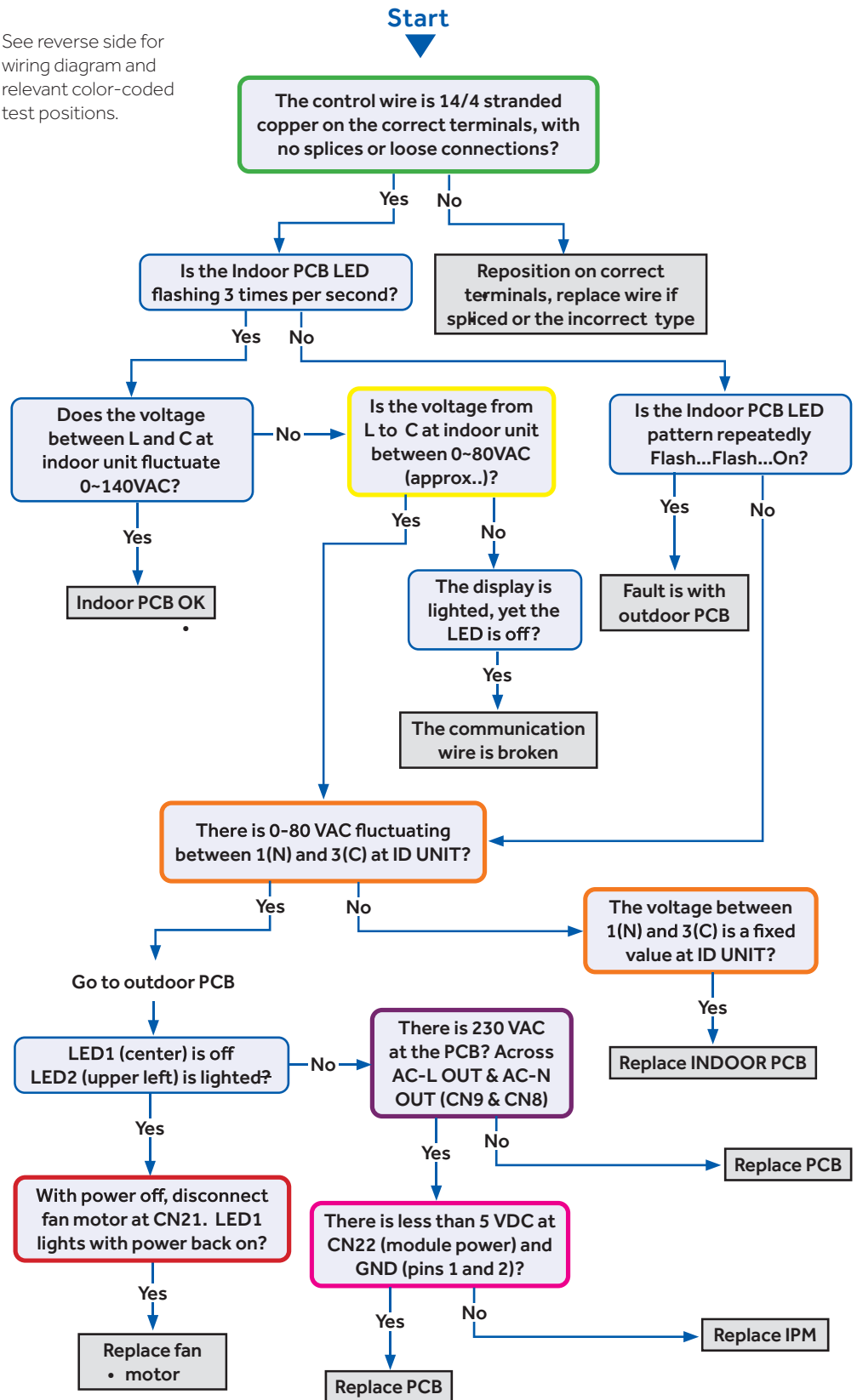

Troubleshooting

Error Code: E7/LED1: 15 Flash

Wiring Diagram Reference

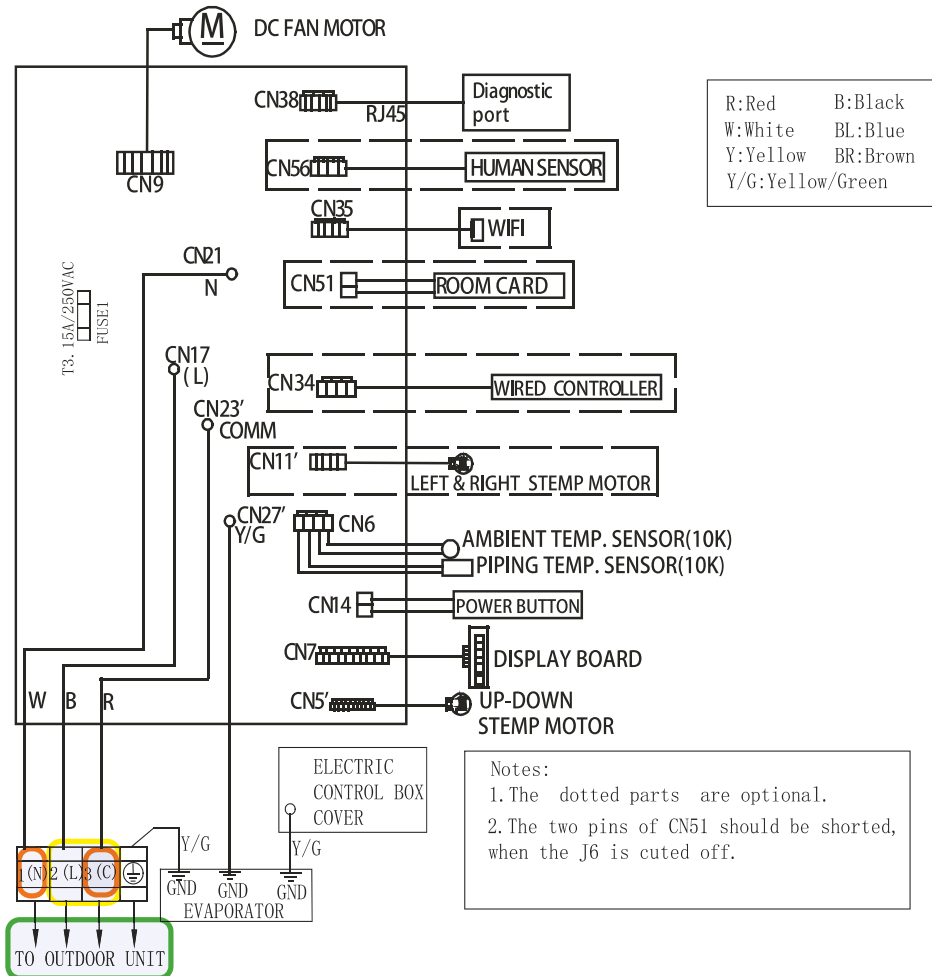

Model selection:

09K	model-23	code - BM1	- 1 off	2 off	Notes: Before replacing the board, it is necessary to ensure that the machine is matched with the board code
12K	model-26	code - BM1	- 1 off	2 on	
07K	model-33	code - BM1	- 1 on	2 off	
18K	model-36	code - BM1	- 1 off	2 off	

Troubleshooting

Error Code: E7/LED1: 15 Flash

Wiring Diagram Reference

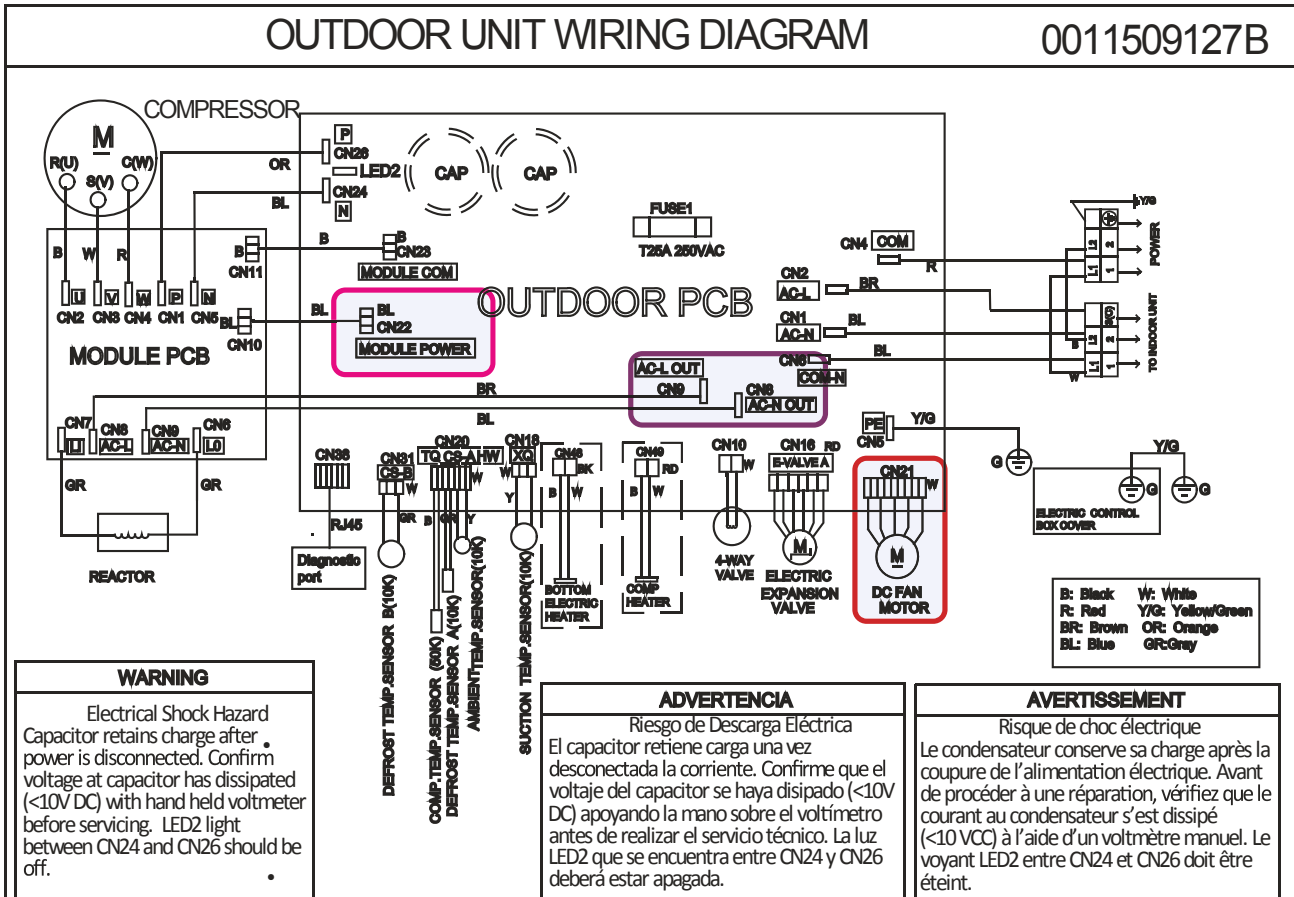

Troubleshooting

Error Code (Indoor)

E14

Indoor Fan Motor Failure

Complete the "Check This First" Flow Chart before continuing.

Models:

- AW09TE2VHA
- AW12TE2VHA
- ASYW09CRDWA
- ASYW12CRDWA

See reverse side for wiring diagram and relevant color-coded test positions.

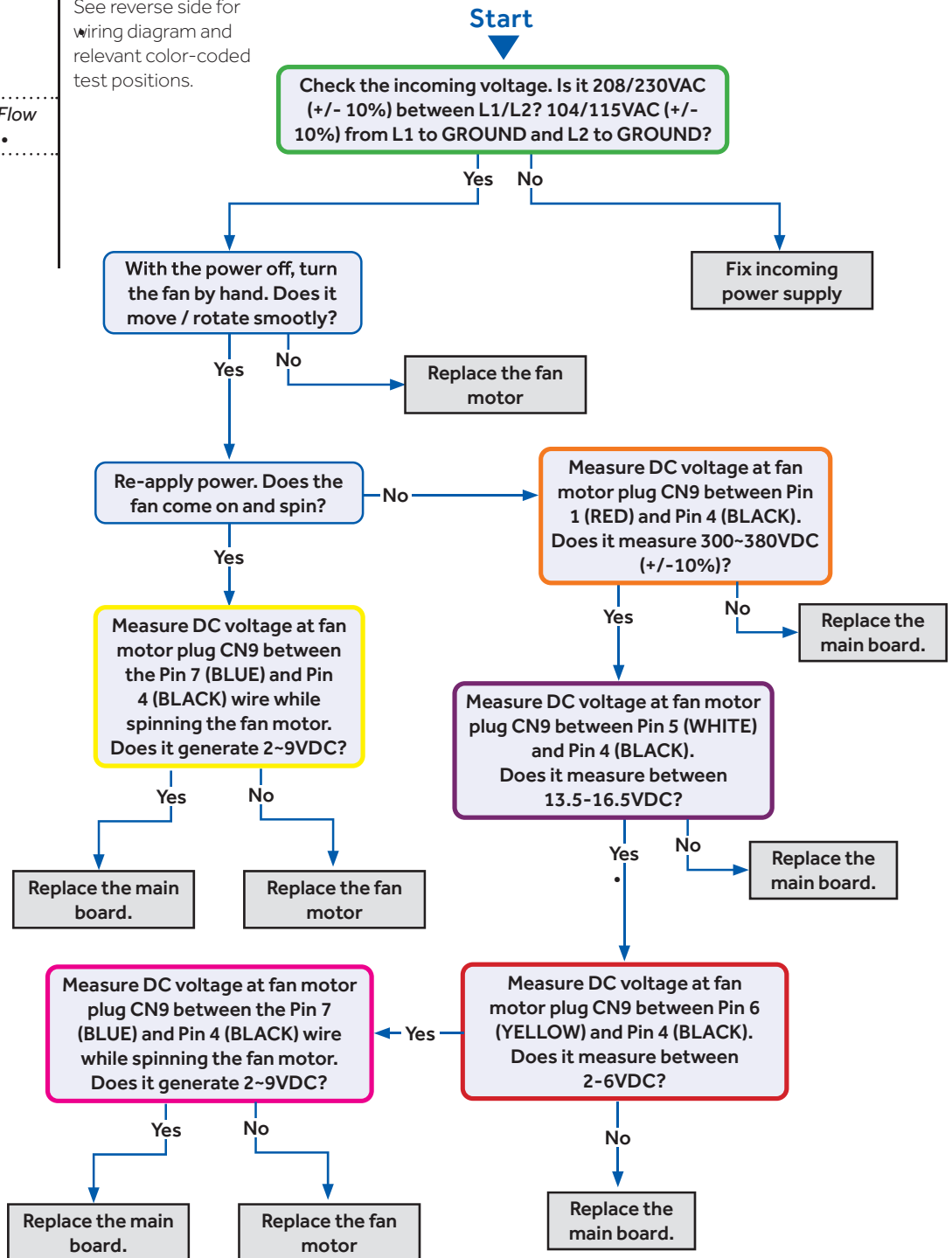

Troubleshooting

Error Code: E14

Wiring Diagram Reference

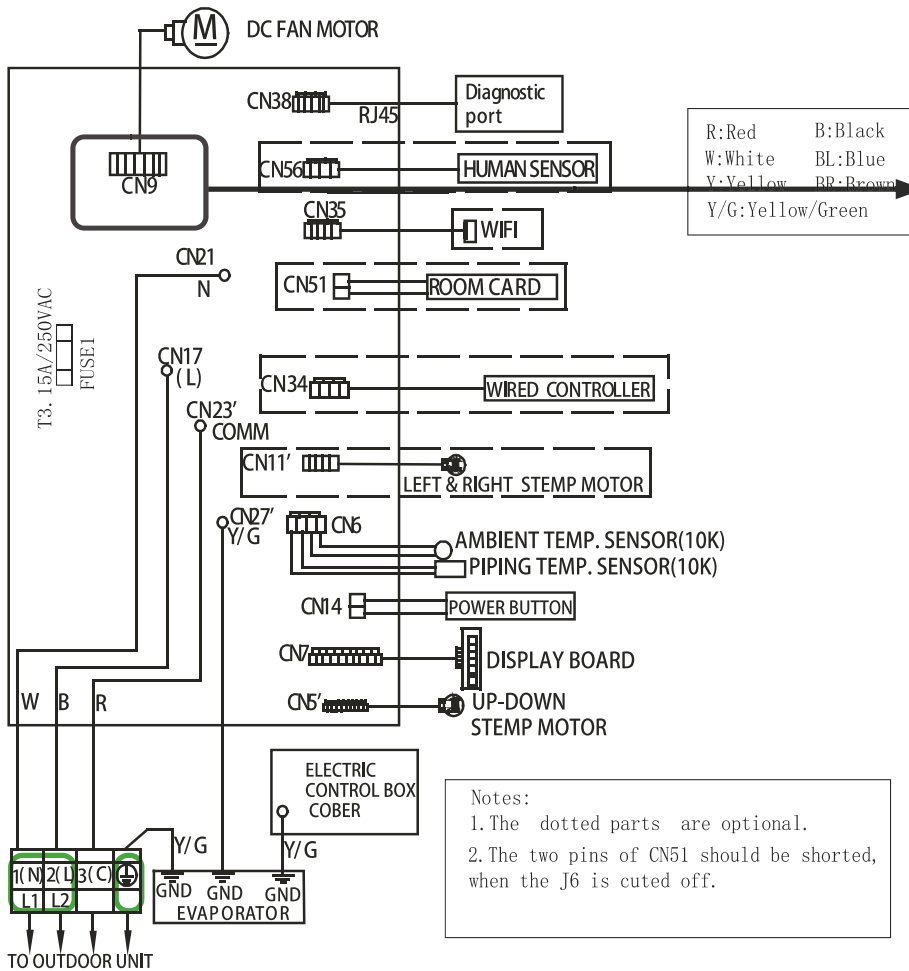

Notes:
 1. The dotted parts are optional.
 2. The two pins of CN51 should be shorted, when the J6 is cutted off.

Model selection:		Notes: Before replacing the board, it is necessary to ensure that the machine is matched with the board code	
09K	model-23 code - BM1 - 1 off 2 off	1	off
12K	model-26 code - BM1 - 1 off 2 on	1	off
07K	model-33 code - BM1 - 1 on 2 off	1	on
18K	model-36 code - BM1 - 1 off 2 off	1	off

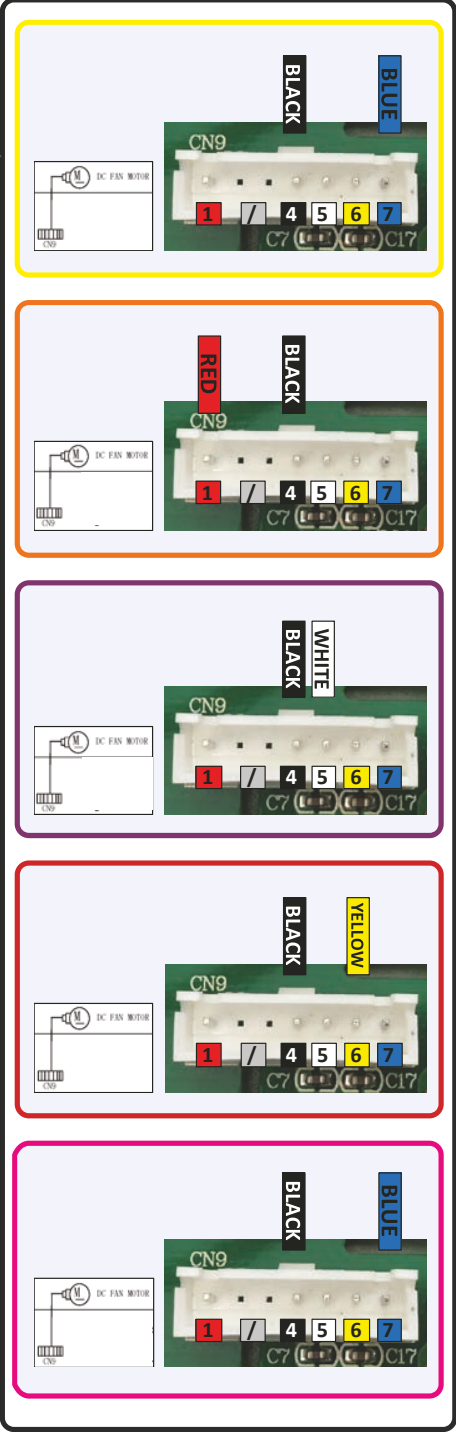

Troubleshooting

Checking System Components

NOTE: Component resistance readings shown in this section are for reference only. Actual resistance values may differ based on model being tested.

Component readings shown below are based on the models of 1U*EH2VHD outdoor unit.

Checking Outdoor Unit Components

Testing of the following components requires the use of needle probes. Avoid testing the connector end of the plug, as damage to the internal sections of the plug can occur.

Checking the Outdoor Unit Sensors

NOTE: Use respective temperature / sensor chart for sensor type being tested.

Compressor discharge sensor
Suction sensor
Defrost temperature sensor
Ambient sensor

Step 1

Disconnect the sensor plug from the control board for this test. Failure to do so may provide inaccurate readings.

Step 2

Using k-type temperature probe, determine the temperature of the sensor being tested.

Step 3

Using an ohmmeter, check the resistance value of the sensor.

Step 4

Referring to the temperature / resistance table for the sensor being checked, verify the resistance value corresponds to the temperature checked in Step 2.

Replace the sensor if the reading is open, shorted, or outside the specifications of the temperature / resistance table.

Step 5

Re-seat the plug on the connector at the conclusion of the test.

Checking the Reversing Valve Coil

Step 1

Disconnect the reversing valve plug from the PCB for this test. Failure to do so may provide inaccurate readings.

Step 2

Using an ohmmeter, check the resistance value of the coil.

The resistance value of the coil should be 1.2 kilo ohms to 1.8 kilo ohms. Replace the valve coil if the reading is significantly different, or if the coil shows open or shorted.

Step 3

Re-seat the plug on the connector at the conclusion of the test.

Checking the DC Fan Motor

Step 1

Using needle probes, check the DCV at the back of the fan plug on the PCB. The values are:

Red to black: +310 VDC

White to black: +15 VDC

Yellow to black: 1-4 VDC when running; 0 VDC when there is no call for heating or cooling

Blue to black: pulsing 0-8 VDC when running; 14 VDC when there is no call for heating or cooling

Checking the EEV Coil

Step 1

Disconnect the EEV coil from the PCB for this test. Failure to do so may provide inaccurate readings.

Step 2

The resistance values of plus pin combinations are 46 Ohm.

Step 3

Re-seat the plug on the connector at the conclusion of the test.

Checking the Compressor Windings

Step 1

Disconnect wiring from terminals U, V and W of the IPM.

Step 1

Using an Ohmmeter, check the resistance value of the compressor windings. Measure between wires U and V, U and W, and V, and W.

The resistance value of the windings should be balanced (equal). If the resistance values are not equal, verify the wiring and connections to the compressor as well as the compressor itself. Repair or replace as needed.

Troubleshooting

Step 3

Reconnect the wiring to the IPM at the conclusion of the test.

NOTE: Resistance readings shown in this section are for reference only

Model	Winding resistance
09K	1.867Ω
12K	1.867Ω

Step 3

Check the resistance value of the sensor.

Step 4

Referring to the temperature / resistance table for the sensor being checked, verify the resistance value corresponds to the temperature checked in step 2.

Replace the sensor if the reading is open, shorted, or outside the specifications of the temperature / resistance table.

Step 5

Re-seat the plug on the PCB at the conclusion of the test.

Checking the Base Pan Heater

The resistance across the heater should be 100 to 500 ohms. Replace it if the value is significantly different, or if the heater reads open or shorted.

Checking Indoor Unit Components

Testing of the following components requires the use of an ohmmeter and k-type temperature probe.

NOTE: When using the test probes, probe the back or side contacts of the plug to obtain the reading. Do not try to probe the connector end of the plug, as this may damage the contacts.

Checking the Indoor Unit Sensors

NOTE: Use respective temperature / sensor chart for sensor type being tested.

Coil sensor

Ambient sensor

Step 1

Disconnect the sensor from the PCB for this test. Failure to do so may provide inaccurate readings.

Step 2

Determine the temperature of the sensor being tested.

Checking the Up/Down Stepper Motor

Step 1

Disconnect the Up/Down Stepper Motor plug PCB for the test. Failure to do so may provide inaccurate readings.

Step 2

Refer to the chart shown below for plug pin combinations and resistance values.

	Red	Orange	Yellow	Pink	Blue
Red		296.5 Ohm	295.5 Ohm	296.3 Ohm	296.1 Ohm
Orange			594.5 Ohm	595.5 Ohm	594.5 Ohm
Yellow				594.3 Ohm	594.5 Ohm
Pink					594.3 Ohm
Blue					

Step 3

Re-seat the plug on the connector at the conclusion of the test.

[This page intentionally left blank.]

Table of Contents

Outdoor Board Diagram	134
Indoor Board Diagram	135
Room and Pipe Sensor Tables	136
Ambient, Defrost, and Pipe Sensor Tables.....	139
Discharge Sensor Tables	142

09K-12K

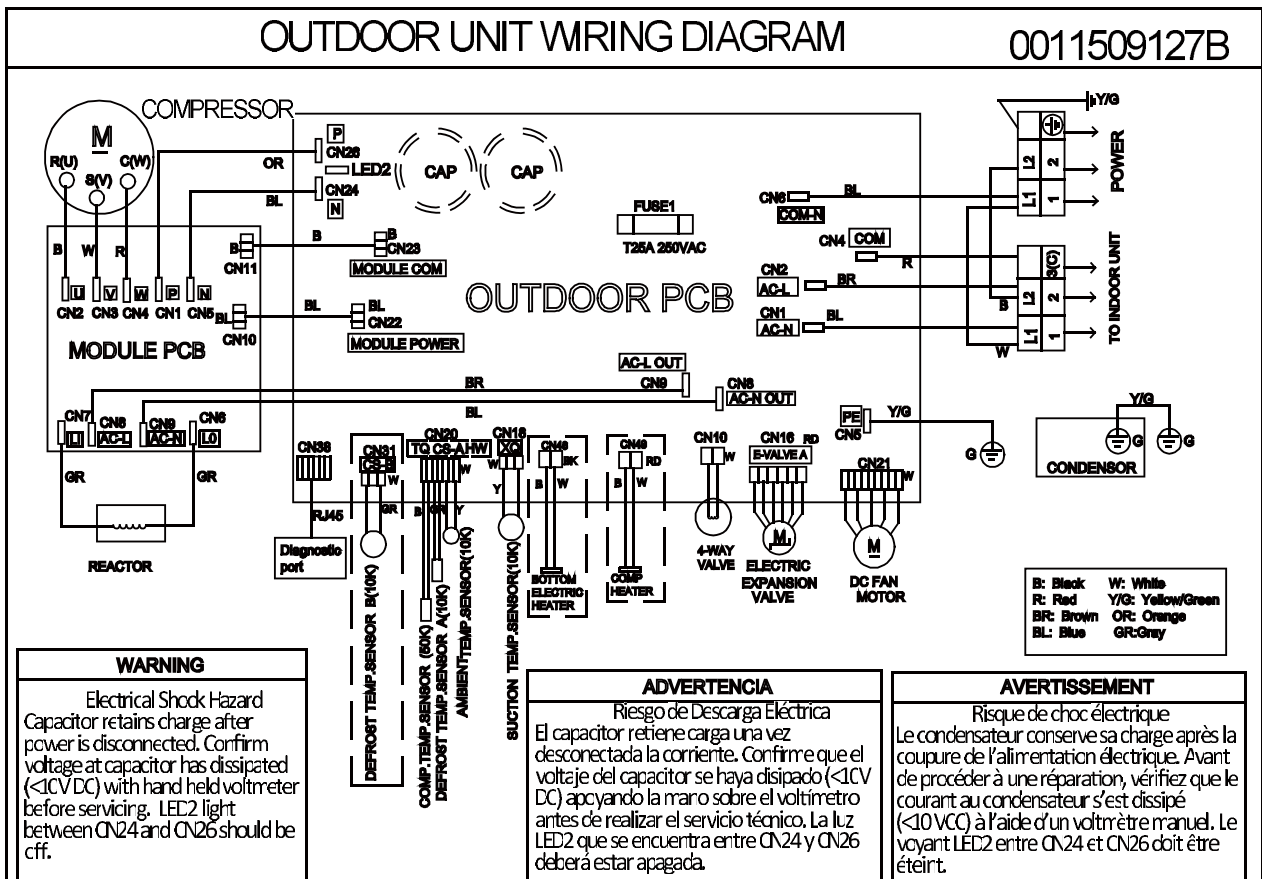

09K-12K

INDOOR UNIT DIAGRAM

0011509128A

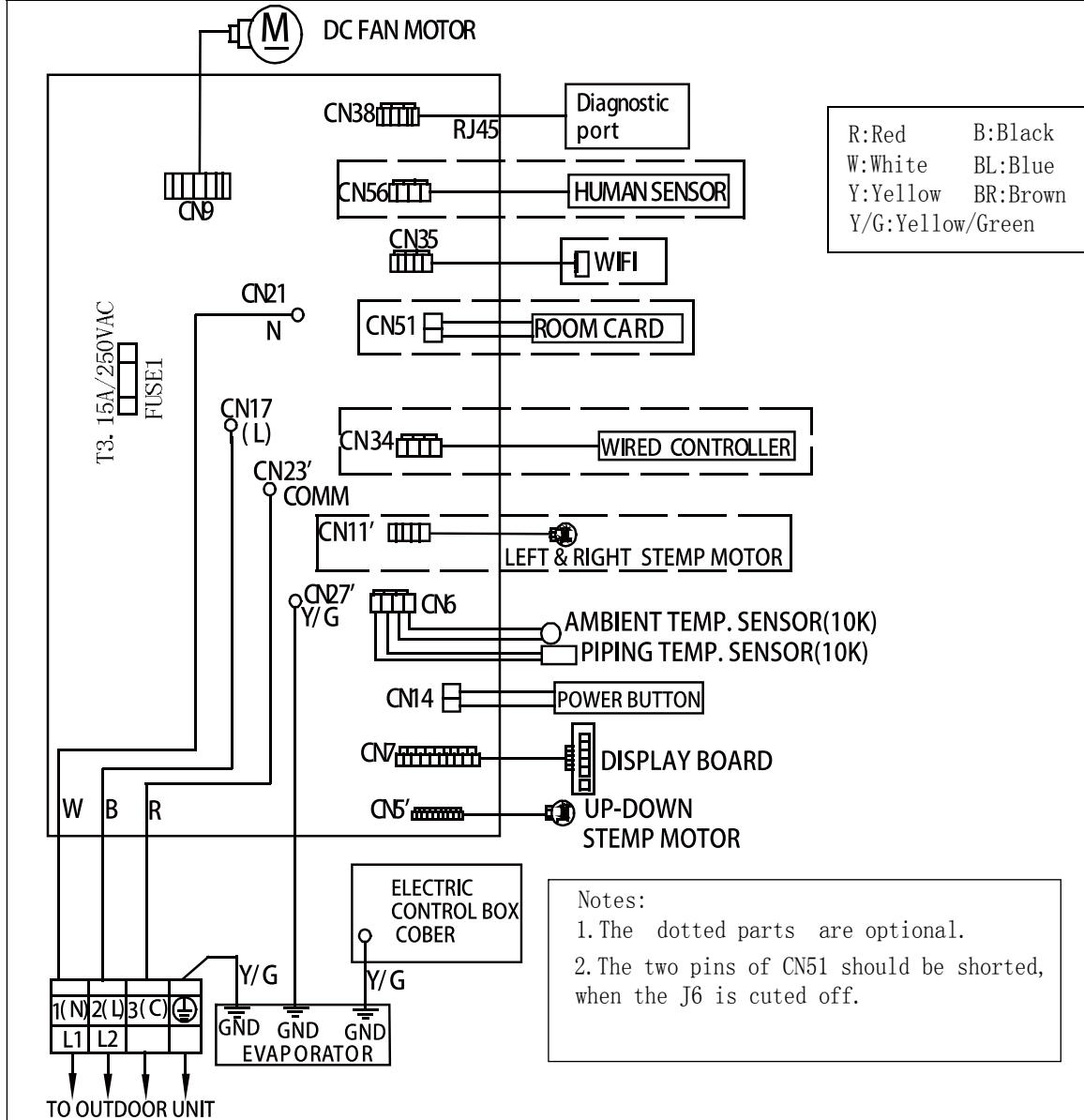

R:Red	B:Black
W:White	BL:Blue
Y:Yellow	BR:Brown
Y/G:Yellow/Green	

Notes:
 1. The dotted parts are optional.
 2. The two pins of CN51 should be shorted, when the J6 is cuted off.

Model selection:		Notes: Before replacing the board, it is necessary to ensure that the machine is matched with the board code	
09K	model-23	code - BM1	- 1 off 2 off
12K	model-26	code - BM1	- 1 off 2 on
07K	model-33	code - BM1	- 1 on 2 off
18K	model-36	code - BM1	- 1 off 2 off

Room and Coil Sensor Tables

R77° = 10KΩ±3%

B77°/122° = 3700K±3%

Temp.°F	Temp. °C	Max.(KΩ)	Normal(KΩ)	Min.(KΩ)	Tolerance (°C)	
-22	-30	165.217	147.9497	132.3678	-1.94	1.75
-20.2	-29	155.5754	139.56	125.0806	-1.93	1.74
-18.4	-28	146.5609	131.7022	118.2434	-1.91	1.73
-16.6	-27	138.1285	124.3392	111.8256	-1.89	1.71
-14.8	-26	130.2371	117.4366	105.7989	-1.87	1.7
-13	-25	122.8484	110.9627	100.1367	-1.85	1.69
-11.2	-24	115.9272	104.8882	94.8149	-1.83	1.67
-9.4	-23	109.441	99.1858	89.8106	-1.81	1.66
-7.6	-22	103.3598	93.8305	85.1031	-1.8	1.64
-5.8	-21	97.6556	88.7989	80.6728	-1.78	1.63
-4	-20	92.3028	84.0695	76.5017	-1.76	1.62
-2.2	-19	87.2775	79.6222	72.5729	-1.74	1.6
-0.4	-18	82.5577	75.4384	68.871	-1.72	1.59
1.4	-17	78.123	71.501	65.3815	-1.7	1.57
3.2	-16	73.9543	67.7939	62.0907	-1.68	1.55
5	-15	70.0342	64.3023	58.9863	-1.66	1.54
6.8	-14	66.3463	61.0123	56.0565	-1.64	1.52
8.6	-13	62.8755	57.911	53.2905	-1.62	1.51
10.4	-12	59.6076	54.9866	50.6781	-1.6	1.49
12.2	-11	56.5296	52.2278	48.2099	-1.58	1.47
14	-10	53.6294	49.6244	45.8771	-1.56	1.46
15.8	-9	50.8956	47.1666	43.6714	-1.54	1.44
17.6	-8	48.3178	44.8454	41.5851	-1.51	1.42
19.4	-7	45.886	42.6525	39.6112	-1.49	1.4
21.2	-6	43.5912	40.58	37.7429	-1.47	1.39
23	-5	41.4249	38.6207	35.9739	-1.45	1.37
24.8	-4	39.3792	36.7676	34.2983	-1.43	1.35
26.6	-3	37.4465	35.0144	32.7108	-1.41	1.33
28.4	-2	35.6202	33.3552	31.2062	-1.38	1.31
30.2	-1	33.8936	31.7844	29.7796	-1.36	1.29
32	0	32.2608	30.2968	28.4267	-1.34	1.28
33.8	1	30.7162	28.8875	27.1431	-1.32	1.26
35.6	2	29.2545	27.5519	25.925	-1.29	1.24
37.4	3	27.8708	26.2858	24.7686	-1.27	1.22
39.2	4	26.5605	25.0851	23.6704	-1.25	1.2
41	5	25.3193	23.9462	22.6273	-1.23	1.18
42.8	6	24.1432	22.8656	21.6361	-1.2	1.16
44.6	7	23.0284	21.8398	20.6939	-1.18	1.14
46.4	8	21.9714	20.8659	19.7982	-1.15	1.12
48.2	9	20.9688	19.9409	18.9463	-1.13	1.09
50	10	20.0176	19.0621	18.1358	-1.11	1.07
51.8	11	19.1149	18.227	17.3646	-1.08	1.05
53.6	12	18.258	17.4331	16.6305	-1.06	1.03
55.4	13	17.4442	16.6782	15.9315	-1.03	1.01
57.2	14	16.6711	15.9601	15.2657	-1.01	0.99
59	15	15.9366	15.277	14.6315	-0.98	0.96
60.8	16	15.2385	14.6268	14.0271	-0.96	0.94

Room and Coil Sensor Tables

Temp.°F	Temp.°C	Max.(KΩ)	Normal(KΩ)	Min.(KΩ)	Tolerance (°C)	
62.6	17	14.5748	14.0079	13.451	-0.93	0.92
64.4	18	13.9436	13.4185	12.9017	-0.91	0.9
66.2	19	13.3431	12.8572	12.3778	-0.88	0.87
68	20	12.7718	12.3223	11.878	-0.86	0.85
69.8	21	12.228	11.8126	11.4011	-0.83	0.83
71.6	22	11.7102	11.3267	10.9459	-0.81	0.8
73.4	23	11.2172	10.8634	10.5114	-0.78	0.78
75.2	24	10.7475	10.4216	10.0964	-0.75	0.75
77	25	10.3	10	9.7	-0.75	0.75
78.8	26	9.8975	9.5974	9.298	-0.76	0.76
80.6	27	9.5129	9.2132	8.9148	-0.8	0.8
82.4	28	9.1454	8.8465	8.5496	-0.84	0.83
84.2	29	8.7942	8.4964	8.2013	-0.87	0.86
86	30	8.4583	8.1621	7.8691	-0.91	0.9
87.8	31	8.1371	7.8428	7.5522	-0.95	0.93
89.6	32	7.8299	7.5377	7.2498	-0.98	0.97
91.4	33	7.5359	7.2461	6.9611	-1.02	1
93.2	34	7.2546	6.9673	6.6854	-1.06	1.04
95	35	6.9852	6.7008	6.4222	-1.1	1.07
96.8	36	6.7273	6.4459	6.1707	-1.13	1.11
98.6	37	6.4803	6.2021	5.9304	-1.17	1.14
100.4	38	6.2437	5.9687	5.7007	-1.21	1.18
102.2	39	6.017	5.7454	5.4812	-1.25	1.22
104	40	5.7997	5.5316	5.2712	-1.29	1.25
105.8	41	5.5914	5.3269	5.0704	-1.33	1.29
107.6	42	5.3916	5.1308	4.8783	-1.37	1.33
109.4	43	5.2001	4.943	4.6944	-1.41	1.36
111.2	44	5.0163	4.763	4.5185	-1.45	1.4
113	45	4.84	4.5905	4.35	-1.49	1.44
114.8	46	4.6708	4.4252	4.1887	-1.53	1.47
116.6	47	4.5083	4.2666	4.0342	-1.57	1.51
118.4	48	4.3524	4.1145	3.8862	-1.61	1.55
120.2	49	4.2026	3.9686	3.7443	-1.65	1.59
122	50	4.0588	3.8287	3.6084	-1.7	1.62
123.8	51	3.9206	3.6943	3.478	-1.74	1.66
125.6	52	3.7878	3.5654	3.3531	-1.78	1.7
127.4	53	3.6601	3.4416	3.2332	-1.82	1.74
129.2	54	3.5374	3.3227	3.1183	-1.87	1.78
131	55	3.4195	3.2085	3.0079	-1.91	1.82
132.8	56	3.306	3.0989	2.9021	-1.95	1.85
134.6	57	3.1969	2.9935	2.8005	-2	1.89
136.4	58	3.0919	2.8922	2.7029	-2.04	1.93
138.2	59	2.9909	2.7948	2.6092	-2.08	1.97
140	60	2.8936	2.7012	2.5193	-2.13	2.01
141.8	61	2.8	2.6112	2.4328	-2.17	2.05
143.6	62	2.7099	2.5246	2.3498	-2.22	2.09
145.4	63	2.6232	2.4413	2.27	-2.26	2.13
147.2	64	2.5396	2.3611	2.1932	-2.31	2.17

Room and Coil Sensor Tables

Temp.°F	Temp.°C	Max.(KΩ)	Normal(KΩ)	Min.(KΩ)	Tolerance (°C)	
149	65	2.4591	2.284	2.1195	-2.36	2.21
150.8	66	2.3815	2.2098	2.0486	-2.4	2.25
152.6	67	2.3068	2.1383	1.9803	-2.45	2.29
154.4	68	2.2347	2.0695	1.9147	-2.49	2.34
156.2	69	2.1652	2.0032	1.8516	-2.54	2.38
158	70	2.0983	1.9393	1.7908	-2.59	2.42
159.8	71	2.0337	1.8778	1.7324	-2.63	2.46
161.6	72	1.9714	1.8186	1.6761	-2.68	2.5
163.4	73	1.9113	1.7614	1.6219	-2.73	2.54
165.2	74	1.8533	1.7064	1.5697	-2.78	2.58
167	75	1.7974	1.6533	1.5194	-2.83	2.63
168.8	76	1.7434	1.6021	1.471	-2.88	2.67
170.6	77	1.6913	1.5528	1.4243	-2.92	2.71
172.4	78	1.6409	1.5051	1.3794	-2.97	2.75
174.2	79	1.5923	1.4592	1.336	-3.02	2.8
176	80	1.5454	1.4149	1.2942	-3.07	2.84
177.8	81	1.5	1.3721	1.254	-3.12	2.88
179.6	82	1.4562	1.3308	1.2151	-3.17	2.93
181.4	83	1.4139	1.291	1.1776	-3.22	2.97
183.2	84	1.373	1.2525	1.1415	-3.27	3.01
185	85	1.3335	1.2153	1.1066	-3.32	3.06
186.8	86	1.2953	1.1794	1.073	-3.38	3.1
188.6	87	1.2583	1.1448	1.0405	-3.43	3.15
190.4	88	1.2226	1.1113	1.0092	-3.48	3.19
192.2	89	1.188	1.0789	0.9789	-3.53	3.24
194	90	1.1546	1.0476	0.9497	-3.58	3.28
195.8	91	1.1223	1.0174	0.9215	-3.64	3.33
197.6	92	1.091	0.9882	0.8942	-3.69	3.37
199.4	93	1.0607	0.9599	0.8679	-3.74	3.42
201.2	94	1.0314	0.9326	0.8424	-3.8	3.46
203	95	1.003	0.9061	0.8179	-3.85	3.51
204.8	96	0.9756	0.8806	0.7941	-3.9	3.55
206.6	97	0.949	0.8558	0.7711	-3.96	3.6
208.4	98	0.9232	0.8319	0.7489	-4.01	3.64
210.2	99	0.8983	0.8088	0.7275	-4.07	3.69
212	100	0.8741	0.7863	0.7067	-4.12	3.74
213.8	101	0.8507	0.7646	0.6867	-4.18	3.78
215.6	102	0.8281	0.7436	0.6672	-4.23	3.83
217.4	103	0.8061	0.7233	0.6484	-4.29	3.88
219.2	104	0.7848	0.7036	0.6303	-4.34	3.92
221	105	0.7641	0.6845	0.6127	-4.4	3.97
222.8	106	0.7441	0.6661	0.5957	-4.46	4.02
224.6	107	0.7247	0.6482	0.5792	-4.51	4.07
226.4	108	0.7059	0.6308	0.5632	-4.57	4.12
228.2	109	0.6877	0.614	0.5478	-4.63	4.16
230	110	0.67	0.5977	0.5328	-4.69	4.21
231.8	111	0.6528	0.582	0.5183	-4.74	4.26
233.6	112	0.6361	0.5667	0.5043	-4.8	4.31

Room and Coil Sensor Tables

Temp.°F	Temp.°C	Max.(KΩ)	Normal(KΩ)	Min.(KΩ)	Tolerance(°C)	
235.4	113	0.62	0.5518	0.4907	-4.86	4.36
237.2	114	0.6043	0.5374	0.4775	-4.92	4.41
239	115	0.5891	0.5235	0.4648	-4.98	4.45
240.8	116	0.5743	0.51	0.4524	-5.04	4.5
242.6	117	0.56	0.4968	0.4404	-5.1	4.55
244.4	118	0.546	0.4841	0.4288	-5.16	4.6
246.2	119	0.5325	0.4717	0.4175	-5.22	4.65
248	120	0.5194	0.4597	0.4066	-5.28	4.7

Ambient , Defrost and Pipe Sensor Tables

Temp.°F	Temp.°C	Max.(KΩ)	Normal(KΩ)	Min.(KΩ)	Tolerance(°C)	
-22	-30	165.2170	147.9497	132.3678	-1.94	1.75
-20	-29	155.5754	139.5600	125.0806	-1.93	1.74
-18	-28	146.5609	131.7022	118.2434	-1.91	1.73
-17	-27	138.1285	124.3392	111.8256	-1.89	1.71
-15	-26	130.2371	117.4366	105.7989	-1.87	1.70
-13	-25	122.8484	110.9627	100.1367	-1.85	1.69
-11	-24	115.9272	104.8882	94.8149	-1.83	1.67
-9	-23	109.4410	99.1858	89.8106	-1.81	1.66
-8	-22	103.3598	93.8305	85.1031	-1.80	1.64
-6	-21	97.6556	88.7989	80.6728	-1.78	1.63
-4	-20	92.3028	84.0695	76.5017	-1.76	1.62
-2	-19	87.2775	79.6222	72.5729	-1.74	1.60
0	-18	82.5577	75.4384	68.8710	-1.72	1.59
1	-17	78.1230	71.5010	65.3815	-1.70	1.57
3	-16	73.9543	67.7939	62.0907	-1.68	1.55
5	-15	70.0342	64.3023	58.9863	-1.66	1.54
7	-14	66.3463	61.0123	56.0565	-1.64	1.52
9	-13	62.8755	57.9110	53.2905	-1.62	1.51
10	-12	59.6076	54.9866	50.6781	-1.60	1.49
12	-11	56.5296	52.2278	48.2099	-1.58	1.47
14	-10	53.6294	49.6244	45.8771	-1.56	1.46
16	-9	50.8956	47.1666	43.6714	-1.54	1.44
18	-8	48.3178	44.8454	41.5851	-1.51	1.42
19	-7	45.8860	42.6525	39.6112	-1.49	1.40
21	-6	43.5912	40.5800	37.7429	-1.47	1.39
23	-5	41.4249	38.6207	35.9739	-1.45	1.37
25	-4	39.3792	36.7676	34.2983	-1.43	1.35
27	-3	37.4465	35.0144	32.7108	-1.41	1.33
28	-2	35.6202	33.3552	31.2062	-1.38	1.31
30	-1	33.8936	31.7844	29.7796	-1.36	1.29
32	0	32.2608	30.2968	28.4267	-1.34	1.28
34	1	30.7162	28.8875	27.1431	-1.32	1.26
36	2	29.2545	27.5519	25.9250	-1.29	1.24
37	3	27.8708	26.2858	24.7686	-1.27	1.22
39	4	26.5605	25.0851	23.6704	-1.25	1.20
41	5	25.3193	23.9462	22.6273	-1.23	1.18
43	6	24.1432	22.8656	21.6361	-1.20	1.16

Ambient , Defrost and Pipe Sensor Tables

Temp.°F	Temp.°C	Max.(KΩ)	Normal(KΩ)	Min.(KΩ)	Tolerance (°C)	
45	7	23.0284	21.8398	20.6939	-1.18	1.14
46	8	21.9714	20.8659	19.7982	-1.15	1.12
48	9	20.9688	19.9409	18.9463	-1.13	1.09
50	10	20.0176	19.0621	18.1358	-1.11	1.07
52	11	19.1149	18.2270	17.3646	-1.08	1.05
54	12	18.2580	17.4331	16.6305	-1.06	1.03
55	13	17.4442	16.6782	15.9315	-1.03	1.01
57	14	16.6711	15.9601	15.2657	-1.01	0.99
59	15	15.9366	15.2770	14.6315	-0.98	0.96
61	16	15.2385	14.6268	14.0271	-0.96	0.94
63	17	14.5748	14.0079	13.4510	-0.93	0.92
64	18	13.9436	13.4185	12.9017	-0.91	0.90
66	19	13.3431	12.8572	12.3778	-0.88	0.87
68	20	12.7718	12.3223	11.8780	-0.86	0.85
70	21	12.2280	11.8126	11.4011	-0.83	0.83
72	22	11.7102	11.3267	10.9459	-0.81	0.80
73	23	11.2172	10.8634	10.5114	-0.78	0.78
75	24	10.7475	10.4216	10.0964	-0.75	0.75
77	25	10.3000	10.0000	9.7000	-0.75	0.75
79	26	9.8975	9.5974	9.2980	-0.76	0.76
81	27	9.5129	9.2132	8.9148	-0.80	0.80
82	28	9.1454	8.8465	8.5496	-0.84	0.83
84	29	8.7942	8.4964	8.2013	-0.87	0.86
86	30	8.4583	8.1621	7.8691	-0.91	0.90
88	31	8.1371	7.8428	7.5522	-0.95	0.93
90	32	7.8299	7.5377	7.2498	-0.98	0.97
91	33	7.5359	7.2461	6.9611	-1.02	1.00
93	34	7.2546	6.9673	6.6854	-1.06	1.04
95	35	6.9852	6.7008	6.4222	-1.10	1.07
97	36	6.7273	6.4459	6.1707	-1.13	1.11
99	37	6.4803	6.2021	5.9304	-1.17	1.14
100	38	6.2437	5.9687	5.7007	-1.21	1.18
102	39	6.0170	5.7454	5.4812	-1.25	1.22
104	40	5.7997	5.5316	5.2712	-1.29	1.25
106	41	5.5914	5.3269	5.0704	-1.33	1.29
108	42	5.3916	5.1308	4.8783	-1.37	1.33
109	43	5.2001	4.9430	4.6944	-1.41	1.36
111	44	5.0163	4.7630	4.5185	-1.45	1.40
113	45	4.8400	4.5905	4.3500	-1.49	1.44
115	46	4.6708	4.4252	4.1887	-1.53	1.47
117	47	4.5083	4.2666	4.0342	-1.57	1.51
118	48	4.3524	4.1145	3.8862	-1.61	1.55
120	49	4.2026	3.9686	3.7443	-1.65	1.59
122	50	4.0588	3.8287	3.6084	-1.70	1.62
124	51	3.9206	3.6943	3.4780	-1.74	1.66
126	52	3.7878	3.5654	3.3531	-1.78	1.70
127	53	3.6601	3.4416	3.2332	-1.82	1.74
129	54	3.5374	3.3227	3.1183	-1.87	1.78

Ambient , Defrost and Pipe Sensor Tables

Temp. °F	Temp. °C	Max.(KΩ)	Normal(KΩ)	Min.(KΩ)	Tolerance(°C)	
131	55	3.4195	3.2085	3.0079	-1.91	1.82
133	56	3.3060	3.0989	2.9021	-1.95	1.85
135	57	3.1969	2.9935	2.8005	-2.00	1.89
136	58	3.0919	2.8922	2.7029	-2.04	1.93
138	59	2.9909	2.7948	2.6092	-2.08	1.97
140	60	2.8936	2.7012	2.5193	-2.13	2.01
142	61	2.8000	2.6112	2.4328	-2.17	2.05
144	62	2.7099	2.5246	2.3498	-2.22	2.09
145	63	2.6232	2.4413	2.2700	-2.26	2.13
147	64	2.5396	2.3611	2.1932	-2.31	2.17
149	65	2.4591	2.2840	2.1195	-2.36	2.21
151	66	2.3815	2.2098	2.0486	-2.40	2.25
153	67	2.3068	2.1383	1.9803	-2.45	2.29
154	68	2.2347	2.0695	1.9147	-2.49	2.34
156	69	2.1652	2.0032	1.8516	-2.54	2.38
158	70	2.0983	1.9393	1.7908	-2.59	2.42
160	71	2.0337	1.8778	1.7324	-2.63	2.46
162	72	1.9714	1.8186	1.6761	-2.68	2.50
163	73	1.9113	1.7614	1.6219	-2.73	2.54
165	74	1.8533	1.7064	1.5697	-2.78	2.58
167	75	1.7974	1.6533	1.5194	-2.83	2.63
169	76	1.7434	1.6021	1.4710	-2.88	2.67
171	77	1.6913	1.5528	1.4243	-2.92	2.71
172	78	1.6409	1.5051	1.3794	-2.97	2.75
174	79	1.5923	1.4592	1.3360	-3.02	2.80
176	80	1.5454	1.4149	1.2942	-3.07	2.84
178	81	1.5000	1.3721	1.2540	-3.12	2.88
180	82	1.4562	1.3308	1.2151	-3.17	2.93
181	83	1.4139	1.2910	1.1776	-3.22	2.97
183	84	1.3730	1.2525	1.1415	-3.27	3.01
185	85	1.3335	1.2153	1.1066	-3.32	3.06
187	86	1.2953	1.1794	1.0730	-3.38	3.10
189	87	1.2583	1.1448	1.0405	-3.43	3.15
190	88	1.2226	1.1113	1.0092	-3.48	3.19
192	89	1.1880	1.0789	0.9789	-3.53	3.24
194	90	1.1546	1.0476	0.9497	-3.58	3.28
196	91	1.1223	1.0174	0.9215	-3.64	3.33
198	92	1.0910	0.9882	0.8942	-3.69	3.37
199	93	1.0607	0.9599	0.8679	-3.74	3.42
201	94	1.0314	0.9326	0.8424	-3.80	3.46
203	95	1.0030	0.9061	0.8179	-3.85	3.51
205	96	0.9756	0.8806	0.7941	-3.90	3.55
207	97	0.9490	0.8558	0.7711	-3.96	3.60
208	98	0.9232	0.8319	0.7489	-4.01	3.64
210	99	0.8983	0.8088	0.7275	-4.07	3.69
212	100	0.8741	0.7863	0.7067	-4.12	3.74
214	101	0.8507	0.7646	0.6867	-4.18	3.78
216	102	0.8281	0.7436	0.6672	-4.23	3.83

Ambient , Defrost and Pipe Sensor Tables

Temp. °F	Temp. °C	Max.(KΩ)	Normal(KΩ)	Min.(KΩ)	Tolerance(°C)	
217	103	0.8061	0.7233	0.6484	-4.29	3.88
219	104	0.7848	0.7036	0.6303	-4.34	3.92
221	105	0.7641	0.6845	0.6127	-4.40	3.97
223	106	0.7441	0.6661	0.5957	-4.46	4.02
225	107	0.7247	0.6482	0.5792	-4.51	4.07
226	108	0.7059	0.6308	0.5632	-4.57	4.12
228	109	0.6877	0.6140	0.5478	-4.63	4.16
230	110	0.6700	0.5977	0.5328	-4.69	4.21
232	111	0.6528	0.5820	0.5183	-4.74	4.26
234	112	0.6361	0.5667	0.5043	-4.80	4.31
235	113	0.6200	0.5518	0.4907	-4.86	4.36
237	114	0.6043	0.5374	0.4775	-4.92	4.41
239	115	0.5891	0.5235	0.4648	-4.98	4.45
241	116	0.5743	0.5100	0.4524	-5.04	4.50
243	117	0.5600	0.4968	0.4404	-5.10	4.55
244	118	0.5460	0.4841	0.4288	-5.16	4.60
246	119	0.5325	0.4717	0.4175	-5.22	4.65
248	120	0.5194	0.4597	0.4066	-5.28	4.70

Discharge Sensor Tables

R176° = 50KΩ±3%

B77°/176° = 4450K±3%

Temp.(°F)	Temp.(°C)	Max.(KΩ)	Normal(KΩ)	Min.(KΩ)	Tolerance	
-22	-30	14646.0505	12061.7438	9924.4999	-2.96	2.45
-20.2	-29	13654.1707	11267.873	9290.2526	-2.95	2.44
-18.4	-28	12735.8378	10531.3695	8700.6388	-2.93	2.44
-16.6	-27	11885.1336	9847.724	8152.2338	-2.92	2.43
-14.8	-26	11096.6531	9212.8101	7641.8972	-2.91	2.42
-13	-25	10365.4565	8622.8491	7166.7474	-2.9	2.42
-11.2	-24	9687.027	8074.3787	6724.1389	-2.88	2.41
-9.4	-23	9057.2314	7564.2244	6311.6413	-2.87	2.41
-7.6	-22	8472.2852	7089.4741	5927.0206	-2.86	2.4
-5.8	-21	7928.7217	6647.4547	5568.2222	-2.84	2.39
-4	-20	7423.3626	6235.7109	5233.3554	-2.83	2.39
-2.2	-19	6953.293	5851.9864	4920.6791	-2.82	2.38
-0.4	-18	6515.8375	5494.2064	4628.5894	-2.8	2.37
1.4	-17	6108.5393	5160.4621	4355.6078	-2.79	2.37
3.2	-16	5729.1413	4848.9963	4100.3708	-2.77	2.36
5	-15	5375.5683	4558.1906	3861.6201	-2.76	2.35
6.8	-14	5045.9114	4286.5535	3638.1938	-2.75	2.34
8.6	-13	4738.4141	4032.7098	3429.0191	-2.73	2.34
10.4	-12	4451.4586	3795.391	3233.1039	-2.72	2.33
12.2	-11	4183.5548	3573.426	3049.5312	-2.7	2.32
14	-10	3933.3289	3365.7336	2877.4527	-2.69	2.31
15.8	-9	3699.5139	3171.3148	2716.0828	-2.67	2.3
17.6	-8	3480.9407	2989.246	2564.6945	-2.66	2.29
19.4	-7	3276.5302	2818.6731	2422.6139	-2.64	2.28
21.2	-6	3085.2854	2658.8058	2289.2164	-2.63	2.28
23	-5	2906.2851	2508.9126	2163.923	-2.61	2.27

Discharge Sensor Tables

Temp.(°F)	Temp.(°C)	Max.(KΩ)	Normal(KΩ)	Min.(KΩ)	Tolerance	
24.8	-4	2738.6777	2368.3158	2046.1961	-2.6	2.26
26.6	-3	2581.6752	2236.3876	1935.5371	-2.58	2.25
28.4	-2	2434.5487	2112.5459	1831.4826	-2.56	2.24
30.2	-1	2296.623	1996.2509	1733.6024	-2.55	2.23
32	0	2167.273	1887.0018	1641.4966	-2.53	2.22
33.8	1	2045.9191	1784.3336	1554.7931	-2.52	2.21
35.6	2	1932.0242	1687.8144	1473.146	-2.5	2.2
37.4	3	1825.0899	1597.0431	1396.2333	-2.48	2.19
39.2	4	1724.654	1511.6468	1323.7551	-2.47	2.17
41	5	1630.287	1431.2787	1255.4324	-2.45	2.16
42.8	6	1541.5904	1355.6163	1191.0048	-2.43	2.15
44.6	7	1458.1938	1284.3593	1130.2298	-2.41	2.14
46.4	8	1379.7528	1217.2282	1072.8813	-2.4	2.13
48.2	9	1305.9472	1153.9626	1018.7481	-2.38	2.12
50	10	1236.4792	1094.32	967.6334	-2.36	2.11
51.8	11	1171.0715	1038.0743	919.3533	-2.35	2.09
53.6	12	1109.4661	985.0146	873.7359	-2.33	2.08
55.4	13	1051.4226	934.944	830.621	-2.31	2.07
57.2	14	996.7169	887.6792	789.8583	-2.29	2.06
59	15	945.1404	843.0486	751.3077	-2.27	2.04
60.8	16	896.4981	800.8922	714.838	-2.26	2.03
62.6	17	850.6086	761.0603	680.3265	-2.24	2.02
64.4	18	807.3024	723.4134	647.658	-2.22	2
66.2	19	766.4212	687.8205	616.7252	-2.2	1.99
68	20	727.8172	654.1596	587.4271	-2.18	1.98
69.8	21	691.3524	622.3161	559.6694	-2.16	1.96
71.6	22	656.8979	592.1831	533.3634	-2.14	1.95
73.4	23	624.3328	563.6604	508.4261	-2.12	1.93
75.2	24	593.5446	536.654	484.7796	-2.1	1.92
77	25	564.4275	511.076	462.351	-2.09	1.9
78.8	26	536.9865	486.9352	441.1516	-2.07	1.89
80.6	27	511.0105	464.05	421.0258	-2.05	1.87
82.4	28	486.4151	442.3499	401.9146	-2.03	1.86
84.2	29	463.1208	421.7683	383.7626	-2.01	1.84
86	30	441.0535	402.243	366.5175	-1.99	1.83
87.8	31	420.1431	383.7151	350.1301	-1.97	1.81
89.6	32	400.3242	366.1295	334.5542	-1.95	1.8
91.4	33	381.535	349.4341	319.746	-1.93	1.78
93.2	34	363.7176	333.5801	305.6645	-1.9	1.76
95	35	346.8176	318.5216	292.2709	-1.88	1.75
96.8	36	330.7839	304.2151	279.5286	-1.86	1.73
98.6	37	315.5682	290.6199	267.4031	-1.84	1.71
100.4	38	301.1254	277.6976	255.862	-1.82	1.7
102.2	39	287.4128	265.4119	244.8745	-1.8	1.68
104	40	274.3905	253.7288	234.4118	-1.78	1.66
105.8	41	262.0206	242.6161	224.4465	-1.76	1.64
107.6	42	250.2676	232.0436	214.9529	-1.74	1.63
109.4	43	239.0983	221.9825	205.9065	-1.71	1.61
111.2	44	228.4809	212.406	197.2844	-1.69	1.59

Discharge Sensor Tables

Temp.(°F)	Temp.(°C)	Max.(KΩ)	Normal(KΩ)	Min.(KΩ)	Tolerance	
113	45	218.386	203.2887	189.0648	-1.67	1.57
114.8	46	208.7855	194.6066	181.2273	-1.65	1.55
116.6	47	199.6531	186.3369	173.7524	-1.63	1.54
118.4	48	190.9639	178.4584	166.6217	-1.6	1.52
120.2	49	182.6945	170.9508	159.8181	-1.58	1.5
122	50	174.8228	163.7951	153.3249	-1.56	1.48
123.8	51	167.328	156.9733	147.1268	-1.53	1.46
125.6	52	160.1904	150.4683	141.209	-1.51	1.44
127.4	53	153.3914	144.2641	135.5577	-1.49	1.42
129.2	54	146.9136	138.3454	130.1598	-1.47	1.4
131	55	140.7403	132.698	125.0027	-1.44	1.38
132.8	56	134.8559	127.3081	120.0746	-1.42	1.36
134.6	57	129.2457	122.163	115.3645	-1.4	1.34
136.4	58	123.8956	117.2504	110.8618	-1.37	1.32
138.2	59	118.7926	112.5589	106.5564	-1.35	1.3
140	60	113.9241	108.0776	102.4388	-1.32	1.28
141.8	61	109.2784	103.7961	98.5	-1.3	1.26
143.6	62	104.8443	99.7046	94.7315	-1.28	1.23
145.4	63	100.6112	95.7939	91.1253	-1.25	1.21
147.2	64	96.5692	92.0553	87.6735	-1.23	1.19
149	65	92.7088	88.4805	84.369	-1.2	1.17
150.8	66	89.0211	85.0614	81.2048	-1.18	1.15
152.6	67	85.4976	81.7908	78.1744	-1.15	1.12
154.4	68	82.1303	78.6615	75.2715	-1.13	1.1
156.2	69	78.9116	75.6668	72.4902	-1.1	1.08
158	70	75.8343	72.8004	69.8249	-1.08	1.06
159.8	71	72.8916	70.0561	67.2703	-1.05	1.03
161.6	72	70.077	67.4283	64.8213	-1.03	1.01
163.4	73	67.3844	64.9115	62.4731	-1	0.99
165.2	74	64.808	62.5006	60.2211	-0.98	0.96
167	75	62.3423	60.1906	58.0609	-0.95	0.94
168.8	76	59.9821	57.977	55.9885	-0.92	0.92
170.6	77	57.7223	55.8552	53.9998	-0.9	0.89
172.4	78	55.5583	53.821	52.0912	-0.87	0.87
174.2	79	53.4856	51.8706	50.2591	-0.85	0.84
176	80	51.5	50	48.5	-0.85	0.84
177.8	81	49.7063	48.2057	46.7083	-0.85	0.85
179.6	82	47.9835	46.4842	44.9911	-0.89	0.89
181.4	83	46.3286	44.8323	43.3452	-0.93	0.92
183.2	84	44.7385	43.2468	41.7672	-0.96	0.95
185	85	43.2105	41.7248	40.254	-1	0.99
186.8	86	41.7386	40.2604	38.7996	-1.03	1.02
188.6	87	40.3241	38.8545	37.4048	-1.07	1.06
190.4	88	38.9643	37.5045	36.0668	-1.11	1.09
192.2	89	37.6569	36.2078	34.7831	-1.14	1.13
194	90	36.3996	34.9622	33.5513	-1.18	1.16
195.8	91	35.1903	33.7653	32.3689	-1.22	1.19
197.6	92	34.0269	32.6151	31.2338	-1.26	1.23
199.4	93	32.9075	31.5096	30.1438	-1.3	1.27

Discharge Sensor Tables

Temp.(°F)	Temp.(°C)	Max.(KΩ)	Normal(KΩ)	Min.(KΩ)	Tolerance	
201.2	94	31.8302	30.4467	29.097	-1.33	1.3
203	95	30.7933	29.4246	28.0915	-1.37	1.34
204.8	96	29.795	28.4417	27.1254	-1.41	1.37
206.6	97	28.8337	27.4961	26.197	-1.45	1.41
208.4	98	27.9078	26.5864	25.3048	-1.49	1.44
210.2	99	27.016	25.711	24.447	-1.53	1.48
212	100	26.1569	24.8685	23.6222	-1.57	1.52
213.8	101	25.329	24.0574	22.8291	-1.61	1.55
215.6	102	24.5311	23.2765	22.0662	-1.65	1.59
217.4	103	23.762	22.5245	21.3323	-1.69	1.63
219.2	104	23.0205	21.8002	20.6261	-1.73	1.66
221	105	22.3055	21.1025	19.9465	-1.77	1.7
222.8	106	21.6159	20.4303	19.2924	-1.81	1.74
224.6	107	20.9508	19.7825	18.6626	-1.85	1.77
226.4	108	20.3091	19.1582	18.0563	-1.89	1.81
228.2	109	19.6899	18.5564	17.4723	-1.93	1.85
230	110	19.0924	17.9761	16.9098	-1.98	1.89
231.8	111	18.5157	17.4166	16.368	-2.02	1.93
233.6	112	17.959	16.8769	15.8458	-2.06	1.96
235.4	113	17.4214	16.3564	15.3427	-2.1	2
237.2	114	16.9023	15.8542	14.8577	-2.15	2.04
239	115	16.401	15.3696	14.3902	-2.19	2.08
240.8	116	15.9167	14.902	13.9394	-2.23	2.12
242.6	117	15.4489	14.4506	13.5047	-2.27	2.16
244.4	118	14.9968	14.0149	13.0855	-2.32	2.19
246.2	119	14.5599	13.5942	12.6811	-2.36	2.23
248	120	14.1376	13.1879	12.2909	-2.41	2.27
249.8	121	13.7294	12.7955	11.9144	-2.45	2.31
251.6	122	13.3347	12.4165	11.551	-2.5	2.35
253.4	123	12.9531	12.0503	11.2003	-2.54	2.39
255.2	124	12.584	11.6965	10.8617	-2.58	2.43
257	125	12.227	11.3545	10.5348	-2.63	2.47
258.8	126	11.8817	11.024	10.2191	-2.68	2.51
260.6	127	11.5475	10.7046	9.9142	-2.72	2.55
262.4	128	11.2242	10.3957	9.6197	-2.77	2.59
264.2	129	10.9112	10.097	9.3352	-2.81	2.63
266	130	10.6084	9.8082	9.0602	-2.86	2.67
267.8	131	10.3151	9.5288	8.7945	-2.91	2.71
269.6	132	10.0312	9.2586	8.5378	-2.95	2.75
271.4	133	9.7563	8.9971	8.2895	-3	2.8
273.2	134	9.4901	8.7441	8.0495	-3.05	2.84
275	135	9.2322	8.4993	7.8175	-3.09	2.88
276.8	136	8.9824	8.2623	7.5931	-3.14	2.92
278.6	137	8.7404	8.0329	7.376	-3.19	2.96
280.4	138	8.5059	7.8108	7.166	-3.24	3
282.2	139	8.2787	7.5958	6.9629	-3.29	3.04
284	140	8.0584	7.3875	6.7664	-3.33	3.09

www.geappliances.com

Model #'s

AW09TE1VHA	1U09TE1VHA
AW12TE1VHA	1U12TE1VHA
AW09TE2VHA	1U09TE2VHA
AW12TE2VHA	1U12TE2VHA
AW18TE2VHA	1U18TE2VHA
AW24TE2VHA	1U24TE2VHA
ASYW09CRAWA	ASH109CRAWA
ASYW12CRAWA	ASH112CRAWA
ASYW09CRDWA	ASH118CRDWA
ASYW12CRDWA	ASH124CRDWA
ASYW18CRDWA	
ASYW24CRDWA	

Revision Date: March 2021



GE APPLIANCES
a Haier company

GE Appliances, A Haier Company
Appliance Park, Louisville, KY 40225
©2021 GE Appliances, A Haier Company