

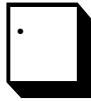

Use and Care & Installation Guide

Refrigerator



English Version	2
Version française	23
Version en español	45



Safety instructions	3
--------------------------------------	---



Operating Instructions, Tips

Automatic Ice maker & Dispenser	5-7
Energy-Saving Tips	2
Food Storage Suggestions	8
Shelves	10
Storage Drawers	9
Temperature Controls	4



Care and Cleaning

Behind the Refrigerator.	11
Cleaning—Inside and Outside	11
Drawer and Cover Removal	12
Light Bulb Replacement	12
Under Refrigerator	11
Water Filter Accessory	7



Problem Solver 17-19

Normal Operating Sounds 17
 More questions? . . . In the United States call
GE Answer Center® 800.626.2000
*In Canada consult your local telephone
 directory for the Cameo Service Center*



Preparation

Clearances	13
Leveling	13
Location	13
Moving & Vacation	13
Rollers	13
Water Supply to Ice maker	13

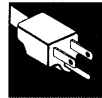

Installation

Installation	14-16
Adapter Plug	14
Electrical Requirements	14
Extension Cord	14
Grounding	14
Water Line installation	15, 16



Consumer Services 20

Appliance Registration	2
Model and Serial Numbers	2
Warranty for Canadian Customers	21
Warranty for U. S. Customers	Back Cover

Profile: Side by Side 22, 24 and 27 Models



HELP US HELP YOU...

Write down the model and serial numbers.

You'll see them on a label on the wall beside the top drawer or at the bottom, just inside the fresh food compartment door.

These numbers are also on the Consumer Product Ownership Registration Card that came with your refrigerator.

Before sending in this card, please write these numbers here:

Model Number

Serial Number

Use these numbers in any correspondence or service calls concerning your refrigerator.

Read this book carefully.

It is intended to help you operate and maintain your new refrigerator properly.

Keep it handy for answers to your questions.

If you don't understand something or need more help, write (include your phone number):

In the United States:

Consumer Affairs
GE Appliance
Appliance Park
Louisville, KY 40225

In Canada:

Manager, Consumer Relations
~&\$5 Sky mark .4\ e.,
Mississauga, Ontario
Canada L4W 4H2

If you received a damaged refrigerator . . .

Immediately contact the dealer (or builder) that sold you the refrigerator.

Save time and money. Before you request service . . .

Check the Problem Solver section in this book. It lists minor operating problems that you can correct yourself.

ENERGY-SAVING TIPS

- Location of your refrigerator is important. Avoid locating it next to your range, a heating vent or where the sun will shine directly on it.
- Close the doors as soon as possible, particularly in hot, humid weather.
- Be sure the doors are closed tightly. Before leaving the house or retiring for the night, check to be sure the doors haven't been left open accidentally.
- Keep foods covered to reduce moisture buildup inside the refrigerator.

IF YOU NEED SERVICE

To obtain service, see the Consumer Services page in the back of this book.

We're proud of our service and want you to be pleased. If for some reason you are not happy with the service you receive, here are 3 steps to follow for further help.

For- Customers in the United States:

FIRST, contact [he people who serviced your appliance. Explain why you are not pleased. In most cases this will solve the problem.

NEXT, if you are still not pleased, write all the details—including your phone number—to:

Manager, Consumer Relations
GE Appliance
Appliance park
Louisville, KY 40225

FINALLY, if your problem is still not resolved, write:

Major Appliance Consumer
Action Panel
20 North Wacker Drive
Chicago, IL 60606

For Customers in Canada:

FIRST, contact the people who serviced your appliance. Explain why you are not pleased. In most cases this will solve the problem.

NEXT, if you are still not pleased, write all the details—including your phone number—to:

Manager, Consumer Relations
2645 Skymark Ave.,
Mississauga, Ontario
Canada L4W 4H2

IMPORTANT SAFETY INSTRUCTIONS

Read all instructions before using this appliance.



A **WARNING**—When using this appliance, always exercise basic safety precautions, including the following:

• **Use this appliance only for its intended purpose** as described in this Use and Care Guide.

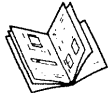

• **This refrigerator must be properly installed and located in accordance with the Installation Instructions before it is used.**

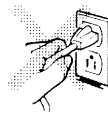

• **Never unplug your refrigerator by pulling on the power cord.** Always grip plug firmly and pull straight out from the outlet.

• **Repair or replace immediately all electric service cords that have become frayed or otherwise damaged.** Do not use a cord that shows cracks or abrasion damage along its length or at either the plug or connector end.

• **When moving your refrigerator away from the wall, be careful not to roll over or damage the power cord.**

• **Do not allow children to climb, stand or hang on the shelves in the refrigerator.** They could damage the refrigerator and seriously injure themselves.

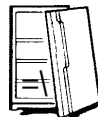

• **If your old refrigerator is still around the house but not in use, be sure to remove the doors.** This will reduce the possibility of danger to children.

• **After your refrigerator is in operation, do not touch the cold surfaces in the freezer compartment? particularly when hands are damp or wet.** Skin may adhere to these extremely cold surfaces.

• **If your refrigerator has an automatic icemaker, avoid contact with the moving parts of the ejector mechanism, or with the heating element that releases the cubes.** Do not place fingers or hands on the automatic icemaking mechanism while the refrigerator is plugged in.

• **Don't refreeze frozen foods which have thawed completely.** The United States Department of Agriculture in Home and Garden Bulletin No. 69 says:

“...You may safely refreeze frozen foods that have thawed if they still contain ice crystals or if they are still cold—below 40°F. (4°C.).

“...Thawed ground meats, poultry or fish that have any off-odor or off-color should not be refrozen and should not be eaten. Thawed ice cream should be discarded. If the odor or color of any food is poor or questionable, get rid of it. The food may be dangerous to eat.

“Even partial thawing and refreezing reduces the eating quality of foods, particularly fruits, vegetables and prepared foods. The eating quality of red meats is affected less than that of many other foods. Use refrozen foods as soon as possible to save as much of their eating quality as you can.”



• **Unplug your refrigerator before cleaning and making repairs.**

NOTE: We strongly recommend that any servicing be performed by a qualified individual.

• **Before replacing a burned-out light bulb, the refrigerator should be unplugged in order to avoid contact with a live wire filament.** (A burned-out light bulb may break when being replaced.)
NOTE: Turning control to OFF position does not remove power to the light circuit.

• **Do not store or use gasoline or other flammable vapors and liquids in the vicinity of this or any other appliance.**

SAVE THESE INSTRUCTIONS



OPERATING YOUR REFRIGERATOR

Set the Temperature Controls (appearance may vary)

The temperature controls let you regulate the temperature in the fresh food and freezer compartments.

At first, set the Fresh Food control at “5” and the Freezer control at “C”.

Allow 24 hours for the temperature to stabilize, whether you are setting the controls for the first time or adjusting them later. Then, if you want colder or warmer temperatures in either compartment, adjust the controls one step at a time.

NOTE: Moving the Fresh Food control to OFF turns off cooling in both compartments—fresh food and freezer—but does not shut off power to the refrigerator.

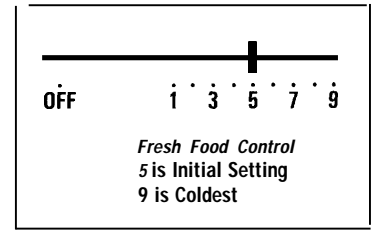
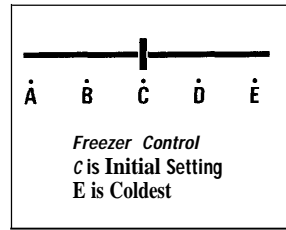

How to Test Temperatures

Use **the milk test for the fresh food compartment.** Place a container of milk on the top shelf in the fresh food compartment. Check it a day later. If the milk is too warm or too cold, adjust the temperature controls.

Use **the ice cream test for the freezer compartment.** Place a container of ice cream in the center of the freezer compartment. Check it after a day. If it's too hard or too soft, adjust the temperature controls.

Always allow 24 hours for the refrigerator to reach the temperature you set.

Automatic Energy Saver System

You won't find an “energy saver” switch on this refrigerator.

Warm liquid from the refrigerator's condenser is automatically circulated around the front edge of the freezer compartment to help keep moisture from forming on the outside of the refrigerator during humid weather.

Many refrigerators use special electric heaters. This refrigerator needs none. That's why there is no “energy saver” switch.. there's no need for it.

No Defrosting

It is not necessary to defrost the freezer or fresh food compartments. Your refrigerator is designed and equipped to defrost itself automatically.

If you turn your household thermostat below 60°F. (16°C.) at night...

... you may want to move the freezer control one step colder. Cooler temperatures in the house may cause the compressor to operate less frequently thus allowing the freezer compartment to warm somewhat. To protect your frozen food supply, leave the freezer setting at this colder setting for the entire winter or for as long as you keep your thermostat turned down.

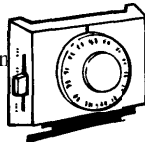

Moving the freezer control to colder setting should have no effect on your fresh food compartment. However, if freezing occurs, move the fresh food control one step warmer.

When you stop turning the thermostat down, turn the refrigerator's controls back to their regular settings.

AUTOMATIC ICEMAKER & DISPENSER

(on some models)



How They Work

The automatic icemaker makes ice continually. The dispenser dispenses water, ice cubes or crushed ice through the freezer compartment door. Here's how they work.

Water flows from the household supply through a

- (1) dual solenoid valve to the
- (2) water tubing and to the
- (3) automatic icemaker as needed.

Water is frozen in the

- (4) cube mold and ejected into the
- (5) storage bin where a motor-powered auger moves cubes forward.

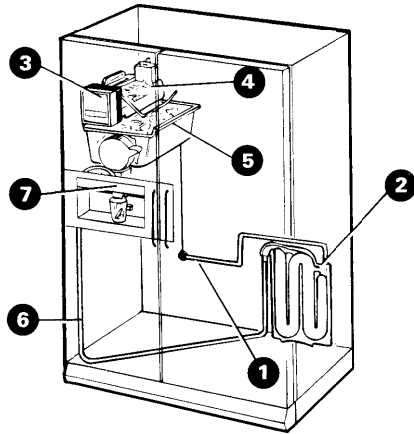

Cubes fall through the chute in the door when the dispenser pad is pressed.

When CRUSHED is selected (on some models), a baffle channels cubes through the crusher and crushed ice falls through a chute into the glass.

When WATER is selected, (on some models) water flows through the (6) tubing in the door and is **dispensed** when the dispenser pad is pressed.

(7) **A light switch (on some models)** turns the nightlight in the dispenser on or off.

The light also comes on when the dispenser pad is pressed.

The light in the dispenser should be replaced with a 7 watt maximum bulb when it burns out.

Important Facts about Your Ice & Water Dispenser

If this is your first icemaker you'll hear occasional sounds that may be unfamiliar. These are normal icemaking sounds and are not cause for concern.

Your icemaker will produce 8 cubes per cycle—approximately 120 cubes in a 24-hour period—depending on freezer compartment temperature, room temperature, number of door openings and other use conditions.

Intermittent dispensing of ice is normal. If ice flow interruption is more than brief, ice clump(s) may be the cause and should be removed following instructions in this section.

Avoid overfilling glasses with ice and using narrow or extra-tall glasses. This can jam the chute or cause the door in the chute to freeze shut. Periodically open the freezer compartment door and look down into the chute. If ice is blocking the chute, poke it through with a wooden spoon.

To help keep bits of ice from being sprayed beyond the glass, place the glass close to the ice chute—but not so close that it blocks outcoming ice.

Fill glasses with ice before adding soda or other beverage mixes.

Beverages and foods should not be quick-chilled in the ice storage bin. Cans, bottles or food packages in the storage bin may cause the icemaker or auger to jam.

Do not add ice from trays or bags to the storage bin. It may not crush or dispense well.

Before Using Your Icemaker and Dispenser

If you use your refrigerator before the water connection is made, raise the ice access door and make sure the icemaker feeler arm is in the STOP (up) position. When the water supply has been connected to the icemaker, move the feeler arm to ON (down) position.

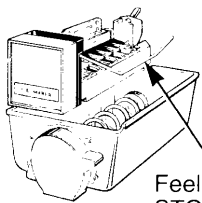
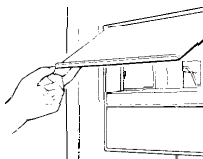

Feeler arm in STOP (up) position

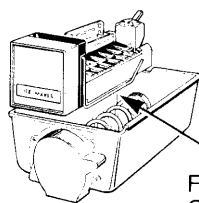

Feeler arm in ON (down) position

At first there will be a delay before water is dispensed and ice is made.

On models with a water dispenser, if no water is dispensed when the refrigerator is first installed, there may be air in the water line system. Press the dispenser pad for at least two minutes to remove trapped air from the water line and to fill the water system.

Push the dispenser pad until the water line is filled.

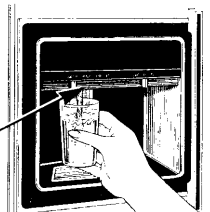

The ice cube mold will automatically fill with water AFTER cooling to freezer temperature. The first cubes normally freeze after several hours.

NOTE: With a newly-installed refrigerator, allow about 24 hours for the freezer compartment to get cold enough to make ice.

(Continued next page)



AUTOMATIC ICEMAKER & DISPENSER

(continued,)

Once Your Icemaker and Dispenser are in Operation

Throw away the first few batches of ice cubes (16 or 24 cubes). This will flush away any impurities in the water line. Do the same thing after vacations or extended periods when ice isn't used.

On models with a water dispenser, pour the first 6 glassfuls of water in the kitchen sink. The first water through the system picks up a slight "plastic" taste from the water tubing.

To make sure the bin fills with ice, level the cubes occasionally. When cubes fall into the bin they may pile up close to the icemaker and push the feeler arm to the STOP (up) position before the bin gets full. Keeping the cubes level allows the icemaker to fill the bin.

To Dispense Ice and Water

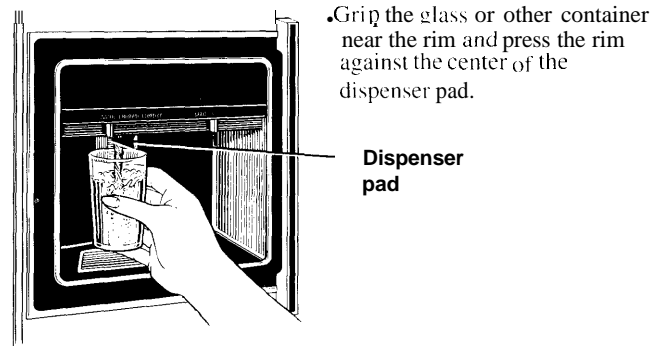
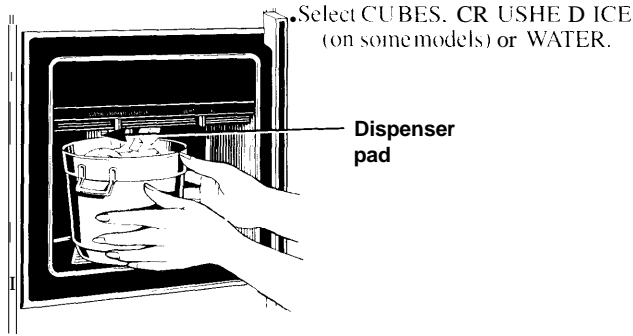

When Dispensing Ice...

Some crushed ice may be dispensed even though you selected CUBES. This happens occasionally when a few cubes get channeled to the crusher.

Sometimes a mound of snow will form on the door in the ice chute. This condition is normal, and usually occurs when you have dispensed crushed ice repeatedly. The snow will eventually evaporate.

Sometimes crushed ice will spray beyond the glass. To avoid this, hold the glass up close to the chute.

CAUTION: Never put fingers or other objects into the dispenser opening.

When Dispensing Water...

The first glass of water dispensed may be warmer than the following ones. This is normal.

Dispensed water is cool, not iced. For colder water, simply add crushed ice or cubes before dispensing water.

To Stop Dispensing

Release pressure from the dispenser pad and wait a few seconds to catch the last bits of ice or 1" drop of water.

There may be some dripping after dispensing crushed ice or water. If there is a lot of dripping, the spill should be wiped dry right away.



Do not pour water in the spill shelf because it is not self-draining--pour it in the kitchen sink. The shelf and its grille should be cleaned regularly according to Care and Cleaning instructions. The grille is easily removed by pressing on the back right corner.

Press here to remove grille

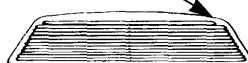

If Ice Clumps Form in the Storage Bin...

The icemaker ejects cubes in groups of 8, and it is normal for several cubes to be joined together. However, if you don't use the ice very often, ice clumps may form in the storage bin and can clog the dispenser.

If this happens:

- Remove the storage bin from the freezer.
- Break up ice clumps with your hands. Throw away any clumps that you can't break up.
- Replace the bin before the remaining cubes melt and fuse together.



To Remove Ice Storage Bin

Lift the left corner to free the bin from the shelf. Pull the bin straight out while supporting it at front and back.

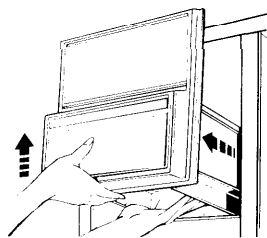

To Replace Ice Storage Bin

Slide the bin back until the tab on the bin lock into the slot in the shelf.

If the bin does not go all the way back, remove it and turn the drive mechanism 1/4 turn. Then push the bin back again until the tab on the bin lock into the slot in the shelf.

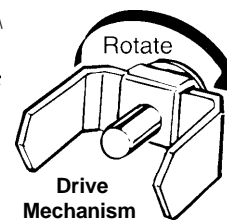

If Ice Is Not Used Often . . .

"Old" ice cubes will become cloudy and taste stale. Empty ice storage bin periodically and wash it in lukewarm water. Be sure to allow storage bin to cool before replacing it—otherwise ice cubes will stick to the metal auger.

Move Feeler Arm to STOP (up) Position when...

- Home water supply is to be turned off for several hours
- Ice storage bin is to be removed for a period of time.
- Going away on vacation, at which time you should also turn off the valve in the water supply line to your refrigerator.

ICE SERVICE

Ice Trays (on some models)

To release ice cubes, invert tray, hold it over storage bin or bowl, and twist at both ends.

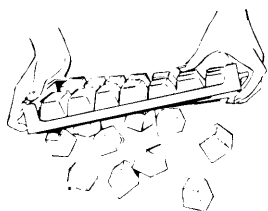

For only one or two ice cubes, leave tray right-side up, twist both ends slightly and remove desired number of cubes.

Wash ice trays and storage bin in lukewarm water only. Do not put them in an automatic dishwasher.

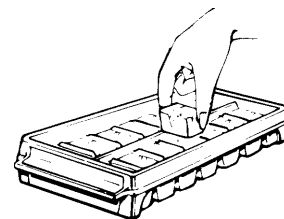

ACCESSORIES

Water Supply Kit

A kit containing copper tubing, shut-off valve fittings and instructions needed to connect the icemaker to your cold water line is available at extra cost. See Preparation section.

Automatic Icemaker Accessory Kit

If your refrigerator did not come already equipped with an automatic icemaker, an Icemaker Accessory Kit is available at extra cost. Check the back of the refrigerator for the specific icemaker kit needed for your model.

Water Filter Accessory

Your ice cubes can only be as fresh-tasting as the water that produces them. That's why it's a good idea to purify your water with a water filter.

REMOVES SEDIMENT

Rigid, porous graded density depth cellulose fiber cartridge catches dirt, rust particles, sand and silt.

REMOVES ODORS

Activated charcoal granules remove musty, stale odors.

IMPROVES TASTE

Activated charcoal granules remove oily, medicinal, plastic and metallic tastes.

REDUCES SCALE

Special crystals reduce hard scale deposit formation.

The water filter is an option at extra cost and is available from your dealer. Specify WR97X0214. It has complete installation instructions and installs in minutes on 1/4" (6 mm) O.D. copper water line.

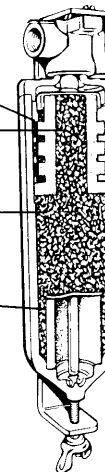



FOOD STORAGE SUGGESTIONS

Suggested storage times for meat and poultry*

Eating quality drops after time shown	DAYS IN REFRIGERATOR AT 35° to 40°F. (2° to 4°C.)	MONTHS IN FREEZER AT 0°F. (-18°C.)
Fresh Meats		
Roasts (Beef & Lamb)	3 to 5	6 to 12
Roasts (Pork & Veal)	3 to 5	4 to 8
Steaks (Beef)	3 to 5	6 to 12
Chops (Lamb)	3 to 5	6 to 9
Chops (Pork)	3 to 5	3 to 4
Ground & Stew Meats	1 to 2	3 to 4
Variety Meats	1 to 2	3 to 4
Sausage (Pork)	1 to 2	1 to 2
Processed Meats		
Bacon	7	1
Frankfurters	7	1/2
Ham (Whole)	7	1 to 2
Ham (Half)	3 to 5	1 to 2
Ham (Slices)	3	1 to 2
Luncheon Meats	3 to 5	Freezing not recommended.
Sausage (Smoked)	7	Freezing not recommended.
Sausage (Dry & Semi-Dry)	14 to 21	Freezing not recommended.
Cooked Meats		
Cooked Meats and Meat Dishes	3 to 4	2 to 3
Gravy & Meat Broth	1 to 2	2 to 3

Eating quality drops after time shown	DAYS IN REFRIGERATOR AT 35° to 40°F. (2° to 4°C.)	MONTHS IN FREEZER AT 0°F. (-18°C.)
Fresh Poultry		
Chicken & Turkey (Whole)	1 to 2	12
Chicken (Pieces)	1 to 2	9
Turkey (Pieces)	1 to 2	6
Duck & Goose (Whole)	1 to 2	6
Giblets	1 to 2	3
Cooked Poultry		
Pieces (Covered with Broth)	1 to 2	6
Pieces (Not Covered)	3 to 4	1
Cooked Poultry Dishes	3 to 4	4 to 6
Fried Chicken	3 to 4	4
(Other than for meats & poultry)		
		FREEZER
Most fruits and vegetables	8-12	months
Lean fish	6-8	months
Fatty fish, rolls and breads, soups, stew, casseroles	2-3	months
Cakes, pies, sandwiches, leftovers (cooked), ice cream (original carton)	1	month max
Meats, fish and poultry purchased from the store vary in quality and age; consequently, safe storage time in your refrigerator will vary.		
*U.S. Department of Agriculture		

Fresh Food Storage Tips

To store vegetables:

- Use the vegetable drawers—they have been designed to preserve the natural moisture and freshness of produce.
- Covering vegetables with a moist towel help maintain crispness.

- As a further aid to freshness, prepackaged vegetables can be stored in their original wrapping.

Unfrozen meats, fish, and poultry:

- Always remove store wrappings.
- Rewrap in foil, plastic wrap or wax paper and refrigerate immediately.

Cheese:

- Wrap well with wax paper or aluminum foil, or put in a plastic bag.
- Carefully wrap to expel air and help prevent mold.
- Store prepackaged cheese in its own wrapping if you wish.

Tips on Freezing Foods

There are 3 essential requirements for efficient home freezing.

- 1. Initial quality.** Freeze only top-quality food. Freezing retains quality and flavor; it cannot improve quality.
- 2. Speed.** The quicker fruits and vegetables are frozen after picking, the better the frozen product will be. You'll save time, too, with less culling and sorting to do.
- 3. Proper packaging.** Use food wrap designed especially for freezing.

To freeze meat, fish and poultry, wrap well in freezer-weight foil (or other heavy-duty wrapping material), forming it carefully to the shape of the contents. This expels air. Fold and crimp ends of the package to provide a good, lasting seal. Don't refreeze meat that has been completely thawed; meat, whether raw or cooked, can be frozen successfully only once.

Fine-quality ice cream, with high cream content, will normally require slightly lower temperatures than more "airy" already packaged brands with low cream content.

- It will be necessary to experiment to determine the freezer compartment location and temperature control setting to keep your ice cream at the right serving temperature.
- The rear of the freezer compartment is slightly colder than the front. *New techniques are constantly being developed. Consult the County Extension Service or your local Utility Company for the latest information on freezing and storing foods.*

STORAGE DRAWERS

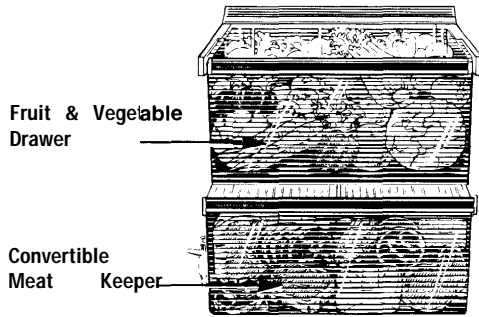

Fruit & Vegetable Drawer (on some models)

This refrigerated drawer keeps unwrapped foods fresh by retaining the natural moisture content of foods such as:

- Artichokes
- Cherries
- Plums
- Asparagus
- Corn
- Radishes
- Beets, topped
- Currants
- Rhubarb
- Blueberries
- Greens, leafy
- Spinach
- Carrots
- Lettuce
- Tomatoes, ripe
- Celery
- Parsley
- Peas, green

As in any refrigerated storage area, it is recommended that foods with strong odors be stored wrapped—foods such as:

- Broccoli
- Cabbage
- Parsnips
- Brussels sprouts
- Cauliflower
- Turnips
- Green onions

Storage time will depend upon the type of food and its condition when placed in the drawers.

Excess water that may accumulate in the bottom of the drawer should be emptied and the drawer wiped dry. The drawer is partially sealed by gaskets attached to the cover. Always replace the drawer in this cover and push the drawer all the way in.

Convertible Meat Drawer (on some models)

The Convertible Meat Drawer has its own cold air duct to allow a stream of cold air from the freezer compartment to flow around the drawer.

The variable temperature control regulates the air flow from the freezer compartment.

Set control lever to MEATS or to the coldest setting to store fresh meats. If lever is left in this position for a long period of time, some frost may form on the inside of the drawer.

Set control lever to VEG or away from the coldest setting to convert the drawer to normal refrigerator temperature and provide extra vegetable storage space. Cold air duct is turned off.

Variable settings between these extremes can be selected.

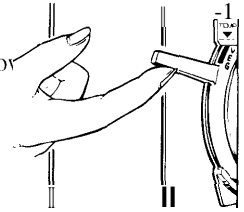

Sealed Snack Pack (on some models)

The sealed Snack Pack—and shelf to which it is attached—can be relocated within the Fresh Food compartment. The sealed drawer retains sufficient humidity for convenient storage of lunch meats, cheese, hors d'oeuvres, spreads and snacks.



SHELVES

How to Rearrange Your Shelves

Shelves in the fresh food compartment are adjustable, enabling you to make efficient shelf arrangements to fit your family's food storage needs.

To remove shelves:

Tilt the shelf up at front, then lift it up and out of the tracks on the rear wall of the refrigerator.

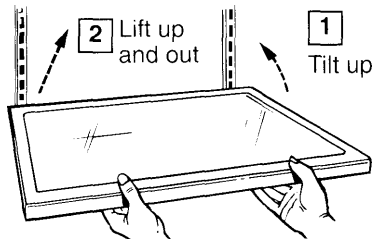

To relocate shelves:

Select desired shelf height. With shelf front raised slightly, engage the top hooks in the tracks at the rear of the cabinet. Then lower the front of the shelf until it locks into position.

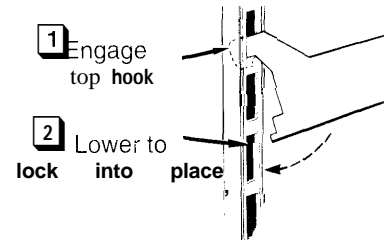

Quick Space Shelf

This shelf splits in half and slides under itself for storage of tall item on the shelf below.

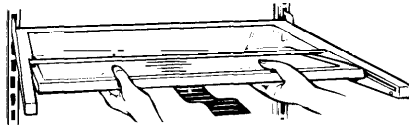

Slide-Out Spillproof Shelf (on some models)

The slide-out shelf allows you to reach items stored behind others. The special edges are designed to help prevent spills from dripping to lower shelves. Make sure you push the shelves all the way back in before you close the door.

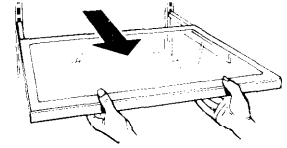

Removable Wine Rack

The wine rack is designed to hold a bottle on its side. A good location for the wine rack is the Quick Space Shelf.

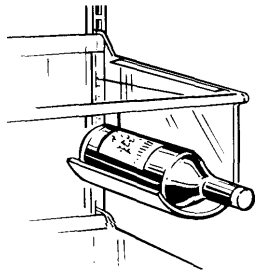

Freezer Baskets (on some models)

Wire slide-out freezer baskets can be pulled out for easy access to frozen foods.

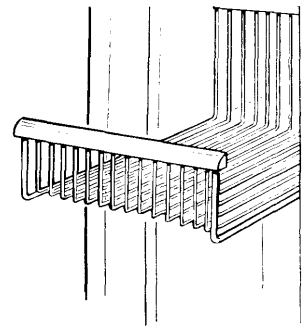

Bins on Fresh Food Compartment Door (on some models)

Adjustable bins can easily be carried from refrigerator to work area.

To remove:

Lift bin straight up until mounting hooks disengage.

To replace or relocate:

Select desired shelf height, engage bin's hook in slots on the tracks of the door, and push in. Bin will lock in place.

The divider (on some models) helps prevent tipping, spilling or sliding of small items stored on the door shelf. Place index finger and middle finger on either side of the divider near the front and simply move it back and forth to fit your needs.

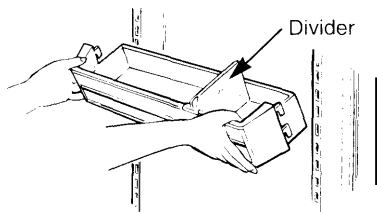

Multi-Position Shelves In Freezer Compartment (on some models)

(on some models)

Shelf supports at various levels in the freezer compartment let you reposition the shelves at your convenience.

Juice Can Rack (on some models)

Cans of frozen juice are easily accessible when stored in the rack on the freezer compartment door.

To load it, place the first can in the bottom of the rack. Then load additional cans into the rack from the top.

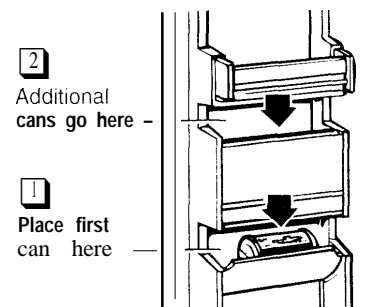

CARE AND CLEANING



Cleaning—Outside

The water and ice dispenser spill shelf (on some models) should be wiped dry immediately to prevent spotting. Water left on the shelf may leave deposits that you can remove by soaking with undiluted vinegar. You can also use a paste of non-precipitating water softener (such as Calgon brand) and water, or 1 teaspoon (5 ml) of citric acid powder per pint (500 ml) of hot tap water. Soak until the deposit disappears or becomes loose enough to rinse away. Usually 30 minutes soaking time is adequate. Avoid using wax on the spill shelf and trim.

The dispenser pad can be cleaned by using a warm water and baking soda solution—about a tablespoon (15 ml) of baking soda to a quart (1 L) of water. Rinse thoroughly with water and wipe dry.

The door handles and trim (on some model) can be cleaned with a cloth dampened with a solution of mild liquid dishwashing detergent and water. Dry with a soft cloth. Don't use wax on the door handles and trim.

The soft door handles (on some models) are easy to keep clean if they are waxed every few months. Use a household wax such as Pledge brand or Jubilee brand to coat the handle. Soil will then easily wash off with a dish detergent and water or a non-abrasive all-purpose cleaner.

Cleaning—Inside

Inside the fresh food and freezer compartments should be cleaned at least once a year. Unplug the refrigerator before cleaning. If this is not practical, wring excess moisture out of sponge or cloth when cleaning around switches, lights or controls.

Use warm water and baking soda solution—about a tablespoon (15 ml) of baking soda to a quart (1 L) of water. This both cleans and neutralizes odors. Rinse thoroughly with water and wipe dry.

Other parts of the refrigerator—including door gaskets, meat and vegetable drawer, ice storage bin and all plastic parts—can be cleaned the same way. After cleaning door gaskets, apply a thin layer of petroleum jelly to the door gaskets at the hinge side. This helps keep the gaskets from sticking and bending out of shape. Do not use cleansing powder or other abrasive cleaner.

Avoid cleaning cold glass shelves with hot water because the extreme temperature difference may cause them to break.

Behind Refrigerator

Caution should be taken in moving your refrigerator away from the wall. All types of floor coverings can be damaged, particularly cushioned coverings and those with embossed surfaces. Pull the refrigerator straight out and return it to position by pushing it straight in. Moving your refrigerator in a side direction may result in damage to your floor covering or refrigerator.

When pushing the refrigerator back, make sure you don't roll over the power cord or icemaker supply line (on some model).

Keep the finish clean. Wipe with a clean cloth lightly dampened with kitchen appliance wax or mild liquid dishwashing detergent. Dry and polish with a clean, soft cloth. Do not wipe the refrigerator with a soiled dishwashing cloth or wet towel. These may leave a residue that can erode the paint. Do not use scouring pads, powdered cleaners, bleach or cleaners containing bleach because these products can scratch and weaken the paint finish.

Protect the paint finish. The finish on the outside of the refrigerator is a high quality, baked-on paint finish. With proper care, it will stay new-looking and rust-free for years. Apply a coat of kitchen/appliance wax when the refrigerator is new and then at least twice a year.

Appliance Polish Wax & Cleaner is available from Service and Part Centers.

To help prevent odors, leave an open box of baking soda in the rear of the refrigerator, on the top shelf. Change the box every 3 months. An open box of baking soda in the freezer will absorb stale freezer odors.

Do not wash any plastic parts from your refrigerator in your automatic dishwasher.

Drain opening in freezer compartment.

During yearly cleaning, remove bottom freezer basket and flush a solution of baking soda—1 teaspoon (5 ml) and 2 cups (500 ml) of hot (not boiling) water—through the drain line with the help of a meat baster. This will help eliminate odor and reduce the likelihood of a clogged drain line. If drain becomes clogged, use a meat baster and baking-soda-and-water solution to force the clog through the drain line.

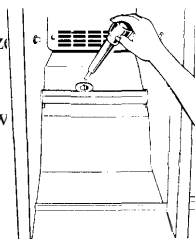

Under Refrigerator

For most efficient operation, you need to keep the area under the refrigerator clean. Remove the base grille and either sweep away or vacuum up dust that is readily accessible. For best results, use a brush specially designed for this purpose. It is available at most appliance parts stores. This easy cleaning operation should be done at least once a year.

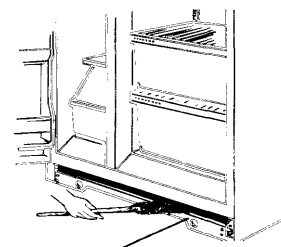

Clean the condenser coils at least once a year.

(continued next page)



CARE AND CLEANING

(continued)

Drawer Removal

Drawers will stop before coming all the way out of the refrigerator to help prevent contents from spilling onto the floor. Drawers can easily be removed by tilting up slightly and pulling past the "stop" location.

To remove drawers when the refrigerator door cannot be opened all the way:

1. Remove food from the drawer and its cover. If your refrigerator has adjustable shelves, remove food from the bottom shelf and temporarily relocate it higher up in cabinet.

2. Remove the flexible gasket at the rear of the top drawer. Lift each end straight up until the slots on the gasket are free of the drawer support tabs.

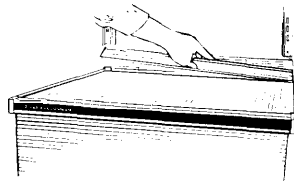

3. Pull the drawer partway out. Reach in, push the rear of the glass lip; at the same time, push it back until it clears the front-corner retainers.

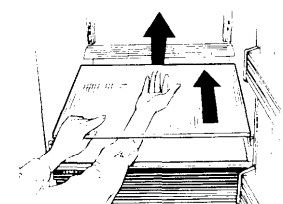

4. Tilt and remove the cover.

5. Pull the drawer forward, lift the front to clear stops, and remove the drawer. If the refrigerator door doesn't open completely, pull the drawer out until it hits the door. Then lift the drawer up until it is higher than the drawer supports, tilt it and take it out.

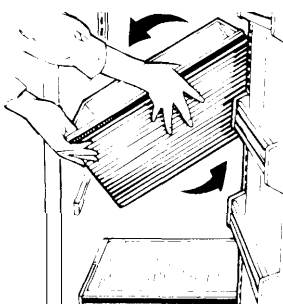

6. If a tape holds the Convertible Meat Drawer (on some models) cover to the drawer supports, remove the tape. Pull drawer partway out. Reach in, push the rear of the glass up and, at the same time, back, until it clears front-corner retainers.

7. Tilt and remove the cover.

Avoid cleaning the cold glass cover with hot water because the extreme temperature difference may cause it to break.

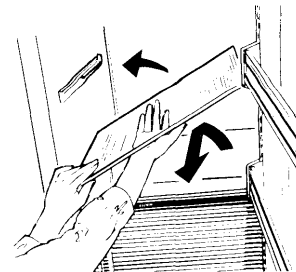

8. Tilt and remove the drawer.

After cleaning, replace in reverse order. When replacing the drawer make sure you slide it through both drawer guides on the left side.

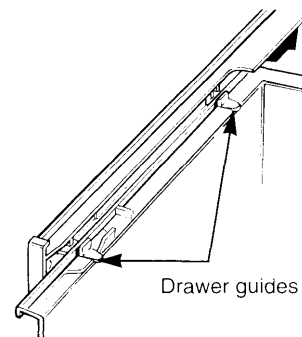

When drawer and covers are back in place, reinstall gasket at the rear of the top drawer. Fit the end of the plastic drawer support into the slot on the gasket, with the rubber gasket flap facing you. Make sure the gasket snaps into place.

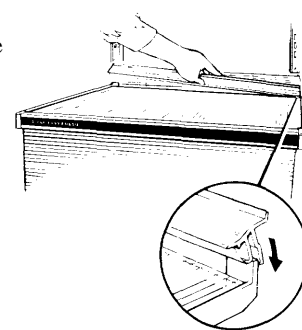

Light Bulb Replacement

Fresh Food Compartment—Upper Light

1. Unplug refrigerator.
2. Pull off the temperature control knobs.
3. Pull bottom of the light shield down and forward, then rotate (tilt top up) and off.

After replacing with same size bulb, reinstall the light shield.

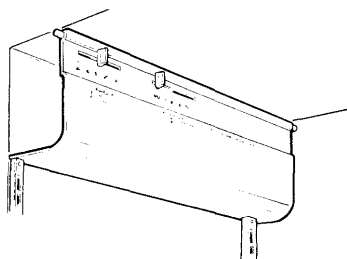

Fresh Food Compartment—Lower Light (on some models)

This light is located behind a shield at the rear of the fresh food compartment.

1. Unplug the refrigerator.
2. Grasp the top edge of the shield and lift it up and forward to free its top edge.
3. After replacing with the same size bulb, hook the top of the shield back in place.

Freezer Compartment

1. Unplug the refrigerator.
 2. Remove the shelf just below light shield. (The shelf will be easier to remove if it is emptied first.)
 3. Pull the light shield toward you to reach the bulb.
- After replacing with same size bulb, reinstall shelf and plug the refrigerator back in.

PREPARATION



Preparing for Vacation

For shorter vacations, remove perishable foods and leave controls at regular settings. However, if room temperature is expected to drop below 60°F (16°C.), follow same instructions in Temperature Control section.

For long vacations or absences, remove food and shut off power to refrigerator. Move the Fresh Food control to OFF position and clean interior with baking soda solution of 1 tablespoon (15 mL) of soda to 1 quart (1 L) of water. Wipe dry. To prevent odors, leave open box of soda in refrigerator. Leave doors open.

Move the icemaker (on some models) feeler arm to STOP (up) position and be sure to shut off water supply to the refrigerator.

Preparing to Move

Disconnect power cord from wall outlet, remove all food, and clean and dry the interior.

Secure all loose items such as grille, shelves and storage pans by taping them securely in place to prevent damage.

Be sure refrigerator stays in upright position during actual moving and in van. Refrigerator must be secured in van to prevent movement. Protect outside of refrigerator with blanket.

Refrigerator Location

Do not install refrigerator where temperature will be below 60°F (16°C.) because it will not run often enough to maintain proper temperatures.

Do install it on a floor strong enough to support a fully loaded refrigerator.

Also see Energy-Saving Tips regarding location.

Clearances

Allow the following clearances for ease of installation, proper air circulation, plumbing and electrical connections.

Side\.....	5/8" (15 mm)
Top	1" (25 mm)
<i>(If built-in, allow 7/8" [22 mm] for hinge covers.)</i>	
Back	1/2" (12 mm)
If the refrigerator is against a wall on either side, allow the following door clearances:	
for 22' and 24' models	3/4" (19 mm)
for 27' model	1 1/8" (38 mm)

Rollers

Adjustable rollers behind the base grille enable you to move the refrigerator away from the wall for cleaning. These rollers should be set so the refrigerator rests firmly on the floor. To assure that the doors will close automatically from a half-way-open position, there is a built-in tilt from the front to the back of the cabinet. Side-by-side refrigerators also have specially designed door hinges that lift both doors slightly when opened, allowing the force of gravity to help close them securely.

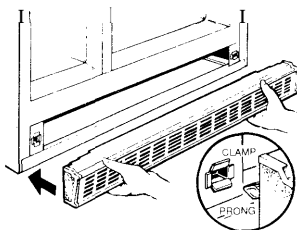

Leveling

To adjust rollers, remove the base grille by grasping it at the bottom and pulling it out.

Turn the roller adjusting screws clockwise to raise the refrigerator, counterclockwise to lower it. Use an adjustable wrench (3/8" [9 mm] hex head bolt) or pliers.

When leveling, you can improve door closure by raising the front approximately 5/8" (15 mm) from the floor.

To replace base grille, align prongs on back of grille with clamps in cabinet and push forward until grille snaps into place.

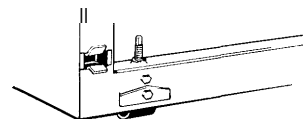

Water Supply to Icemaker (on some models)

If your refrigerator has an icemaker, or if you plan to add an icemaker later, the icemaker will have to be connected to a cold water line. A water supply kit containing copper tubing, shut-off valve, fittings and instructions is available at extra cost from your dealer. There should be sufficient tubing for the icemaker from the cold water supply to allow you to move the refrigerator out from the wall several feet (approximately 8 feet [244 cm] of 1/4" [6 mm] copper tubing in three 10-inch [25 cm] diameter coils).



INSTALLATION REQUIREMENTS

IMPORTANT... PLEASE READ CAREFULLY

How to Connect Electricity

For personal safety, this appliance must be properly grounded.

The power cord of this appliance is equipped with a 3-prong (grounding) plug which mates with a standard 3-prong (grounding) wall outlet to minimize the possibility of electric shock hazard from this appliance.

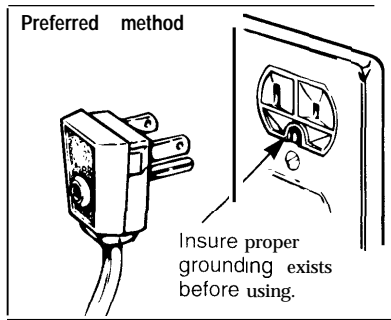

Have the wall outlet and circuit checked by a qualified electrician to make sure the outlet is properly grounded.

Where a standard 2-prong wall outlet is encountered, it is your personal responsibility and obligation to have it replaced with a properly grounded 3-prong wall outlet.

DO NOT, UNDER ANY CIRCUMSTANCES, CUT OR REMOVE THE THIRD (GROUND) PRONG FROM THE POWER CORD.

Use of Adapter Plug

Because of potential hazards under certain conditions, we strongly recommend against the use of an adapter plug. However, if you still elect to use an adapter, where local codes permit, a TEMPORARY CONNECTION may be made to a properly grounded 2-prong wall outlet by use of a UL-listed adapter available at most local hardware stores.

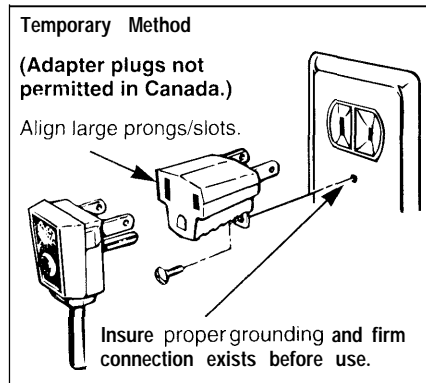

The larger slot in the adapter must be aligned with the larger slot in the wall outlet to provide proper polarity in the connection of the power cord.

Use of an adapter plug will increase the clearance needed for the back of the refrigerator.

CAUTION: Attaching the adapter ground terminal to a wall outlet cover screw does not ground the appliance unless the cover screw is metal, and not insulated, and the wall outlet is grounded through the house wiring. You should have the circuit checked by a qualified electrician to make sure the outlet is properly grounded.

When disconnecting the power cord from the adapter, always hold the adapter in place with one hand while pulling the power cord plug with the other hand. If this is not done, the adapter ground terminal is very likely to break with repeated use.

Should the adapter ground terminal break, DO NOT USE the appliance until a proper ground has again been established.

Electrical Requirements

The refrigerator should always be plugged into its own individual electrical outlet which has a voltage rating that matches the rating plate. This provides the best performance and also prevents overloading house wiring circuits which could cause a fire hazard from overheated wires.

Use of Extension Cords

Because of potential safety hazards under certain conditions, we strongly recommend against the use of an extension cord. However, if you still elect to use an extension cord, it is absolutely necessary that it be a UL-listed 3-wire grounding type appliance extension cord having a grounding type plug and outlet and that the electrical rating of the cord be 15 amperes (minimum) and 120 volts.

WATER LINE INSTALLATION INSTRUCTIONS



CAUTION:

• If you use your refrigerator before connecting the water line, make sure the icemaker feeler arm is kept in the STOP (up) position.

- Do not install the icemaker tubing in areas where temperatures fall below freezing.
- When using any electrical device (such as a power drill) during installation, be sure the device is insulated or wired in a manner to prevent the hazard of electric shock.
- All installations must be in accordance with local plumbing code requirements.

WHAT YOU WILL NEED

• A **cold** water supply is required for automatic icemaker operation. The water pressure must be between 20 and 120 p.s.i.

- **Power drill**, unless you have a self-piercing valve.
- Copper tubing, 1/4" (6 mm) outer diameter to connect the refrigerator to the water supply. Be sure both ends of the tubing are cut square.

To determine how much copper tubing you need: measure the distance from the water valve on the back of the refrigerator to the water supply pipe. Then add 8 feet (244 cm). Be sure there is sufficient extra tubing (about 8 feet [244 cm] coiled into 3 turns of about 10 inches [25 cm] diameter) to allow the refrigerator to move out from the wall after installation. Do not use plastic tubing or plastic fittings because the water supply line is under pressure at all times. Also, certain types of plastic tubing may become brittle with age and crack, resulting in water leakage.

• **Shutoff valve** to connect to the cold water line. The shut-off valve should have a water inlet with a minimum inside diameter of 5/32" (4 mm) at the point of connection to the COLD WATER LINE. Saddle-type shut-off valves are included in many water supply kits. Before purchasing, make sure a saddle-type valve complies with your local plumbing codes.

• Two 1/4" (6 mm) outer diameter compression nuts and 2 ferrules (sleeves)—to connect the copper tubing to the shutoff valve and the refrigerator water valve.

• If your existing water line has a flared fitting at the end, you will need an **adapter** (available at plumbing supply stores) to connect the water line to the refrigerator OR—you can cut off the flared fitting with a **tube** cutter and then use a compression fitting.

WARRANTY INFORMATION

This water line installation is not warranted by the refrigerator or icemaker manufacturer. Follow these instructions carefully to minimize the risk of expensive water damage.

SHUT OFF THE MAIN WATER SUPPLY.

Turn on the nearest faucet long enough to clear the line of water.

2 INSTALL THE SHUTOFF VALVE ON THE NEAREST FREQUENTLY USED DRINKING WATER LINE.

Typical ways to connect to water supply

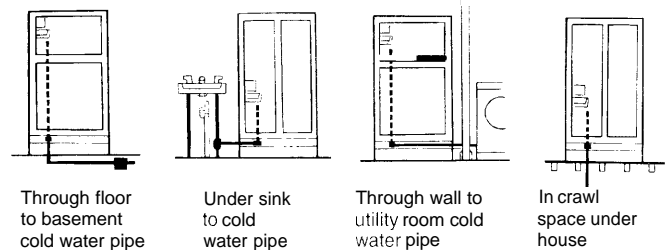

a. Choose a location for the valve that is easily accessible. It is best to connect into the side of a vertical water pipe. When it is necessary to connect into a horizontal water pipe, make the connection to the top or side, rather than at the bottom, to avoid drawing off any sediment from the water pipe.

b. Drill a 1/4" (6 mm) hole in the water pipe, using a sharp bit. Remove any burrs resulting from drilling the hole in the pipe. (Do not drill a hole if the valve is a self-piercing type.)

c. Fasten the shutoff valve to the cold water pipe with the pipe clamp.

d. Tighten the clamp screws until the sealing washer begins to swell. Do not overtighten or you may crush the copper tubing.

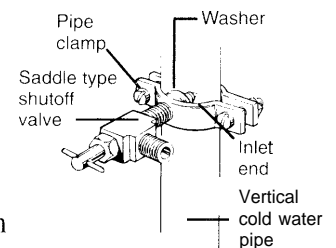

(continued next page)



WATER LINE INSTALLATION INSTRUCTIONS

(continued)

1 ROUTE THE COPPER TUBING BETWEEN THE COLD WATER LINE AND THE REFRIGERATOR.

Route the tubing through a hole drilled in the floor or wall (behind the refrigerator or adjacent base cabinet) as close to the wall as possible. Be sure there is sufficient extra tubing (about 8 feet [244 cm] coiled into 3 turns of about 10" [25 cm] diameter) to allow the refrigerator to move out from the wall after installation.

2 CONNECT THE COPPER TUBING TO THE SHUTOFF VALVE.

Place the compression nut and ferrule (sleeve) onto the end of the tubing and connect it to the shutoff valve. Make sure the tubing is fully inserted into the valve. Tighten the compression nut securely.

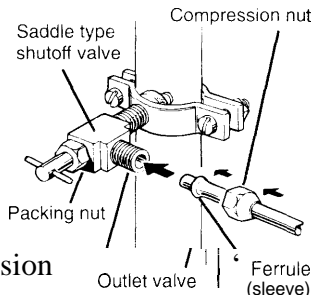

5 TURN ON THE WATER AND FLUSH OUT THE TUBING.

- a. Turn the main water supply on and flush out the tubing until the water is clear.
- b. Shut the water off at the water valve after about one quart of water has been flushed through the tubing.

6 CONNECT THE COPPER TUBING TO THE REFRIGERATOR.

Before making the connection to the refrigerator, be sure the refrigerator power cord is not plugged into the wall outlet.

We recommend installing a water filter (available at Service and Parts Centers) if your water supply has sand or particles that could clog the screen of the refrigerator's water valve. Install it in the water line near the refrigerator.

- a. Remove the plastic flexible cap from the water valve.

- b. Place the compression nut and ferrule (sleeve) onto the end of the tubing as shown.

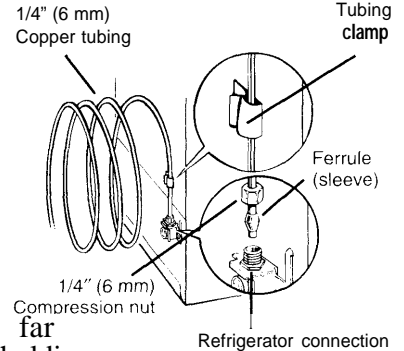

- c. Insert the end of the copper tubing into the water valve connection as far as possible. While holding the tubing, tighten the fitting.

- d. Fasten the copper tubing into the clamp provided to hold it in a vertical position. You may need to pry open the clamp.

7 TURN THE WATER ON AT THE SHUTOFF VALVE.

Tighten any connections that leak.

8 PLUG THE REFRIGERATOR POWER CORD INTO A GROUNDED ELECTRICAL OUTLET.

9 SET THE ICEMAKER FEELER ARM TO THE ON (DOWN) POSITION.

The icemaker will not begin to operate until it reaches its operating temperature of 15° E (-9° C.) or below. It will then begin operation automatically if the icemaker is in the ON (down) position.

NOTE: The icemaker may double-cycle when it first starts, causing some water spillage from the icemaker into the ice bucket. This is normal and should not happen again. The first few batches of cubes should be thrown away, so that remaining impurities in the water line will be flushed out.

10 MOVE THE REFRIGERATOR BACK TO THE WALL.

Arrange the coil of copper tubing so that it does not vibrate against the back of the refrigerator or against the wall.

QUESTIONS? USE THIS PROBLEM SOLVER



PROBLEM	POSSIBLE CAUSE
REFRIGERATOR DOES NOT OPERATE	<ul style="list-style-type: none"> • May be in defrost cycle when motor does not operate for about 30 minutes. • Temperature control in OFF position. • If interior light is not on, refrigerator may not be plugged in at wall outlet. • If plug is secure and the refrigerator still fails to operate, plug a lamp or a small appliance into the same outlet to determine if there is a tripped circuit breaker or burned out fuse.
MOTOR OPERATES FOR LONG PERIODS	<ul style="list-style-type: none"> • Modern refrigerators with more storage space and a larger freezer compartment require more operating time. • Normal when refrigerator is first delivered to your home—usually requires 24 hours to completely cool down. • Large amounts of food placed in refrigerator to be cooled or frozen. • Hot weather—frequent door openings. • Door left open. • Temperature controls are set too cold. Refer to instructions for use of Temperature Controls. • Grille and condenser need cleaning. Refer to Care and Cleaning page. • Check Energy-Saving Tips.
MOTOR STARTS & STOPS FREQUENTLY	<ul style="list-style-type: none"> • Temperature control starts and stops motor to maintain even temperatures.
VIBRATION OR RATTLING	<ul style="list-style-type: none"> • If refrigerator vibrates, more than likely it is not resting solidly on the floor and front roller screws or front leveling legs need adjusting, or floor is weak or uneven. Refer to Rollers section on Installation Requirements page. • If dishes vibrate on shelves, try moving them. Slight vibration is normal.

NORMAL OPERATING SOUNDS

These **sounds are normal and do not indicate a need for service.**

The new high efficiency compressor runs faster and will have a higher pitch hum or pulsating sound while operating.

Defrost timer and refrigerator control clicks on and off.

The fan circulating air inside the freezer which keeps the temperatures throughout.

Water dropping on the defrost heater causing a sizzling, hissing or popping sound during the defrost cycle.

The flow of refrigerant through the freezer cooling coil sounds like boiling water or a gurgling noise.

Cracking or popping of cooling coils caused by expansion and contraction during defrost and refrigeration following defrost.

Water dripping as it melts from the evaporator and flows to the drain pan during the defrost cycle.

Icemaker (on some models)

The icemaker water valve will buzz when the icemaker fills with water. If the feeler arm is in the ON (down) position it will buzz even if it has not yet been hooked up to water. Keeping the feeler arm in the ON (down) position before it is hooked up to water can damage the icemaker. To prevent this, raise the feeler arm to the STOP (up) position. This will stop the buzzing.

The sound of cubes dropping into the bin and water running in pipes as icemaker refills.

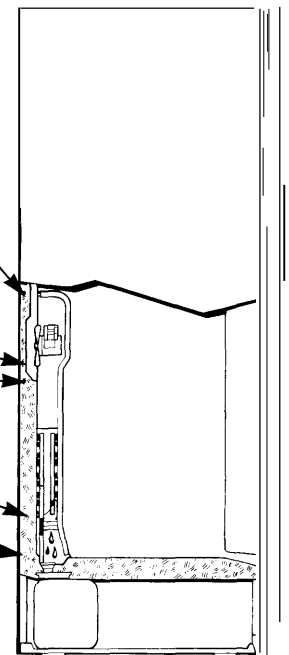

(continued next page)



PROBLEM SOLVER

(continued)

PROBLEM	POSSIBLE CAUSE
HOT AIR FROM BOTTOM OF REFRIGERATOR	<ul style="list-style-type: none">• Normal air flow cooling motor. In the refrigeration process, it is normal that heat be expelled in the area under the refrigerator. Some floor coverings will discolor at these normal and safe operating temperatures. Your floor covering supplier should be consulted if you object to this discoloration.
DOOR NOT CLOSING PROPERLY	<ul style="list-style-type: none">• Door gasket on hinge side sticking or folding over. To correct, put a small amount of petroleum jelly on face of gasket.
FRESH FOOD OR FREEZER COMPARTMENT TEMPERATURE TOO WARM	<ul style="list-style-type: none">• Temperature control not set cold enough. Refer to Temperature Control section.• Warm weather—frequent door openings.• Door left open for long time.• Package may be holding door open.
FOODS DRY OUT	<ul style="list-style-type: none">• Foods not covered, wrapped or sealed properly.
FROST OR ICE CRYSTALS ON FROZEN FOOD	<ul style="list-style-type: none">. Door may have been left ajar or package holding door open.. Too frequent or too long door openings.• Frost within package is normal.
SLOW ICE CUBE FREEZING	<ul style="list-style-type: none">• Door may have been left open.• Turn temperature of freezer compartment colder.
ICE CUBES HAVE ODOR/TASTE (on some models)	<ul style="list-style-type: none">• Old cubes need to be discarded.• Ice storage bin needs to be emptied and washed,• Unsealed packages in refrigerator and/or freezer compartments may be transmitting odor/taste to ice cubes.. Interior of refrigerator needs cleaning—refer to Care and Cleaning section• Poor-tasting incoming water. Install a water filter—see Water Filter Accessory section.
AUTOMATIC ICEMAKER DOES NOT WORK (on some models)	<ul style="list-style-type: none">• ON-STOP control in STOP (up) position.• Water supply turned off or not connected.• Freezer compartment too warm.• Cubes too small—water shutoff valve connecting refrigerator to home water line may be clogged.• Sometimes cubes fuse to the side of the ice mold and hold the feeler arm in the STOP (up) position. Remove this ice to restart the icemaker.• When reaching for cubes by hand, you may have pushed the feeler arm into the STOP (up) position by mistake.• Piled up cubes in storage bin may cause icemaker to shut off too soon. With icemaker feeler arm in-STOP (up) position, level cubes in bin.
CUBE DISPENSER DOES NOT WORK (on some models)	<ul style="list-style-type: none">• No ice cubes. Remove storage container. If cubes are frozen to wire arm, remove cubes.• No ice cubes. Icemaker turned off or water supply turned off.• Irregular ice clumps in storage container. Break up as many as you can with fingertip pressure and discard the remaining clumps.



PROBLEM	POSSIBLE CAUSE
WATER HAS POOR TASTE/ODOR (on some models)	<ul style="list-style-type: none">• If the water dispenser has not been used for a long time, dispense water in regular manner until all water in the system is replenished with fresh water.• Poor-tasting incoming water. Install a water filter—see Water Filter section.
WATER IN FIRST GLASS IS WARM (on some models)	<ul style="list-style-type: none">• Allow about 24 hours for water to cool to proper temperature after refrigerator is first installed.• If water dispenser has not been used for a long time, water in first glass will not be as cool as in succeeding glasses.• If the water system has been drained, allow several hours for replenished supply to chill.
WATER DISPENSER DOES NOT WORK (on some models)	<ul style="list-style-type: none">• Water supply line turned off or not connected.• Supply line may be clogged with sediment.• If no water is dispensed when the refrigerator is first installed, there may be air in the water system. Press the dispenser pad for at least two minutes to remove trapped air from the water line and to fill the water system.
DIVIDER BETWEEN FRESH FOOD AND FREEZER COMPARTMENTS FEELS WARM	<ul style="list-style-type: none">• Normal warmth is created by automatic energy saver system circulating warm liquid around front edge of freezer compartment to help prevent condensation on outside of refrigerator in hot, humid weather.
MOISTURE FORMS ON OUTSIDE OF REFRIGERATOR	<ul style="list-style-type: none">• Not unusual during periods of high humidity.
MOISTURE COLLECTS INSIDE	<ul style="list-style-type: none">• Too frequent or too long door openings.• In humid weather, air carries moisture into refrigerator when doors are opened.
WATER ON KITCHEN FLOOR OR ON BOTTOM OF FREEZER	<ul style="list-style-type: none">• The drain in the bottom of the refrigerator may be clogged. Remove any ice on the freezer bottom and clean the drain. Refer to Care and Cleaning section.• When using the dispenser use a glass no taller than six inches (15 cm) tall. A taller glass may be jamming cubes in the funnel chute. They can fuse inside the chute and drop out later, leaving water or ice on the floor.
REFRIGERATOR HAS ODOR	<ul style="list-style-type: none">• Foods with strong odors should be tightly covered.• Check for spoiled food.• Interior needs cleaning. Refer to Care and Cleaning section.• Defrost water system needs cleaning.• Keep open box of baking soda in refrigerator; replace every 3 months.
INTERIOR LIGHT DOES NOT WORK	<ul style="list-style-type: none">• No power at outlet.• Light bulb needs replacing. See Care and Cleaning section.

If you need more help... In the United States call, toll free:
GE Answer Center™, 800.626.2000 consumer information service

In Canada: Manager, Consumer Relations
7645 Skymark Ave., Mississauga, **Ontario, Canada L4W 4H2**



We'll Be There

With the purchase of your new GE appliance, receive the assurance that if you ever need information or assistance from GE, we'll be there. All you have to do is call—or write!

In-Home Repair Service In the United States: 800-GE-CARES (800-432-2737)

A GE consumer service professional will provide expert repair service, scheduled at a time that's convenient for you. Many GE Consumer Service company-operated locations offer you service today or tomorrow, or at your convenience (7:00 a.m. to 7:00 p.m. weekdays, 9:00 a.m. to 2:00 p.m. Saturdays). Our factory-trained technicians know your appliance inside and out—so most repairs can be handled in just one visit.

In Canada consult your local telephone directory for the Cameo Service or Authorized Service Center nearest you.

GE Answer Center® In the United States: 800.626.2000

Whatever your question about any GE major appliance, GE Answer Center® information service is available to help. Your call—and your question—will be answered promptly and courteously. And you can call any time. GE Answer Center® service is open 24 hours a day, 7 days a week.

In Canada contact Manager, Consumer Relations, Cameo, Inc., 2645 Skymark Avenue, Mississauga, Ontario, Canada L4W4H2

For Customers With Special Needs... In the United States: 800.626.2000

Upon request, GE will provide Braille controls for a variety of GE appliances, and a brochure to assist in planning a barrier-free kitchen for persons with limited mobility. To obtain these items, free of charge, call 800.626.2000.

Consumers with impaired hearing or speech who have access to a TDD or a conventional teletypewriter may call 800-TDD-GEAC (800-833-4322) to request information or service.

In Canada contact Manager, Consumer Relations, Camco, Inc., 2645 Skymark Avenue, Mississauga, Ontario, Canada L4W 4H2

Service Contracts In the United States: 800-626-2224

You can have the secure feeling that GE Consumer Service will still be there after your warranty expires. Purchase a GE contract while your warranty is still in effect and you'll receive a substantial discount. With a multiple-year contract, you're assured of future service at today's prices.

800-461-3636 In Canada

Parts and Accessories In the United States: 800-626-2002

Individuals qualified to service their own appliances can halt needed parts or accessories sent directly to their home. The GE parts system provides access to (nearly 47,000 parts... and all GE Genuine Renewal Parts are fully warranted. **MasterCard and Discover cards are accepted.**

User maintenance instructions contained in this booklet cover procedures intended to be performed by any user. Other servicing generally should be referred to qualified service personnel. Caution must be exercised, since improper servicing may cause unsafe operation.

In Canada consult your local telephone directory for the Cameo Service or Authorized Service Center nearest you.

CONSUMER WARRANTY

(for customers in Canada)

FIRST YEAR

CAMCO warrants the replacement or repair of all parts of this Refrigerator which prove to be defective in material or workmanship, for one year from the date of purchase. Such parts will be repaired or replaced at the option of Cameo without charge, subject to the terms and conditions set out below.

The DEALER warrants to provide the service labor for the repair or replacement of all parts of this Refrigerator which prove to be defective in material or workmanship for one year from the date of purchase.

NEXT FOUR YEARS

CAMCO warrants the hermetically sealed refrigerator system (namely: Evaporator, Condenser, Motor Compressor, interconnecting Tubing, Drier and Refrigerant Charge) against defects in material or workmanship for an additional four years. These parts will be repaired or replaced at the option of Cameo without charge, subject to the terms and conditions set out below.

The DEALER warrants for the next four years to provide the service labor necessary to repair or replace the hermetically sealed refrigeration system, subject to the terms and conditions set out below.

TERMS AND CONDITIONS

1. This warranty applies only to single family domestic use in Canada when the Refrigerator has been properly installed according to the instructions supplied by Cameo and is connected to an adequate and proper utility service. Damage due to abuse, accident, commercial use, and alteration or the removal or defacing of the serial plate, cancels all obligations of this warranty. Service during this warranty must be performed by an Authorized Cameo Service Agent.
2. Neither Cameo nor the Dealer is liable for any claims or damages resulting from any failure of the Refrigerator or from service delays beyond their reasonable control.
3. To obtain warranty service, purchaser must present the original bill of sale. Components repaired or replaced are warranted through the remainder of the original warranty period only.
4. This warranty does not cover expense involved in making this appliance readily accessible for servicing.
5. This warranty gives you specific legal rights. Additional warranty rights may be provided by law in some areas.

Cameo Service is available coast-to-coast. See preceding page for service information.

If further help is needed concerning this Warranty, contact:

Manager, Consumer Relations
Cameo Inc., Consumer Service
2645 Skymark Avenue,
Mississauga, Ontario
L4W 4H2

Part No. 162D7734P002
Pub. No. 49-6784

Side by Side 22, 24 and 27 Models

YOUR GENERAL ELECTRIC REFRIGERATOR WARRANTY

(for customers in the United States)

Staple sales slip or cancelled check here. Proof of original purchase date is needed to obtain service under warranty.

WHAT IS COVERED

FULL ONE-YEAR WARRANTY

For one year from date of original purchase, we will provide, free of charge, parts and service labor in your home to repair or replace **any part of the refrigerator** that fails because of a manufacturing defect.

FULL FIVE-YEAR WARRANTY

For five years from date of original purchase, we will provide, free of charge, parts and service labor in your home to repair or replace any part of the sealed refrigerating system (the compressor, condenser, evaporator and all connecting tubing) that fails because of a manufacturing defect.

LIMITED LIFETIME WARRANTY

For the life of the refrigerator, we will replace, free of charge, **any see-through pan or drawer made from Lexan® polycarbonate resin** and furnished with the refrigerator if the pan or drawer breaks during normal household use. Drawer covers are not included. The drawers can be exchanged at a GE Service and Parts Center, or by writing to the address below.

This warranty is extended to the original purchaser and any succeeding owner for products purchased for ordinary home use in the 48 mainland states, Hawaii and Washington, D.C. In Alaska the warranty is the same except that it is LIMITED because you must pay to ship the product to the service shop or for the service technician's travel costs to your home.

All warranty service will be provided by our Factory Service Centers or by our Authorized Customer Care® servicers during normal working hours.

Should your appliance need service, during warranty period or beyond, call 800-GE-CARES (800-432-2737).

WHAT IS NOT COVERED

- Service trips to your home to teach you how to use the product.

Read your Use and **Care** material. If you then have any questions about operating the product, please contact your dealer or our Consumer Affairs office at the address below, or call, toll free:

GE Answer Center®
800.626.2000
consumer information service

- Improper installation.

If you have an installation problem, contact your dealer or installer. You are responsible for providing adequate electrical, plumbing and other connecting facilities.

- Replacement of house fuses or resetting of circuit breakers.
- Failure of the product if it is used for other than its intended purpose or used commercially.
- Damage to product caused by accident, fire, floods or acts of God.
- Loss of food due to spoilage.

WARRANTOR IS **NOT**
RESPONSIBLE FOR
CONSEQUENTIAL DAMAGES.

Some states do not allow the exclusion or limitation of incidental or consequential damages, so the above limitation or exclusion may not apply to you. This warranty gives you specific legal rights, and you may also have other rights which vary from state to state. To know what your legal rights are in your state, consult your local or state consumer affairs office or your state's Attorney General.

Warrantor: General Electric Company

If further help is needed concerning this warranty, write:
Manager—Consumer Affairs, Appliance Park, Louisville, KY 40225

This book is printed on recycled paper.

Part No. 162 D7734PO02
Pub. No. 49-6784

Side by Side 22, 24 and 27 Models

Printed in the United States